

# The Historian's Gaze

Essays on Modern  
and Contemporary  
China in Honour  
of Guido Samarani

edited by  
Laura De Giorgi and Sofia Graziani



**Edizioni**  
Ca'Foscari

e-ISSN 2610-9042 ISSN 2610-9654

Sinica venetiana 10



The Historian's Gaze

## **Sinica venetiana**

Serie diretta da  
Tiziana Lippiello e Chen Xiaoming

10



**Edizioni**  
Ca' Foscari

# Sinica venetiana

## **Direzione scientifica | Editors-in-chief**

Tiziana Lippiello (Università Ca' Foscari Venezia, Italia)

Chen Xiaoming (Peking University, China)

## **Comitato scientifico | Advisory board**

Sebastian Eicher (Università Ca' Foscari Venezia, Italia) Sean Golden (UAB Barcelona, España) Roger Greatrex (Lunds Universitet, Sverige) Chen Hongmin (Zhejiang University, Hangzhou, China) Jin Yongbing (Peking University, China) Olga Lomova (Univerzita Karlova v Praze, Česká Republika) Michael Puett (Harvard University, Cambridge, USA) Tan Tian Yuan (SOAS, London, UK) Hans van Ess (LMU, München, Deutschland) Wang Keping (CASS, Beijing, China) Yamada Tatsuo (Keio University, Tokyo, Japan) Yang Zhu (Peking University, China)

## **Comitato editoriale | Editorial board**

Magda Abbiati (Università Ca' Foscari Venezia, Italia) Attilio Andreini (Università Ca' Foscari Venezia, Italia) Giulia Baccini (Università Ca' Foscari Venezia, Italia) Bianca Basciano (Università Ca' Foscari Venezia, Italia) Daniele Beltrame (Università per Stranieri di Perugia, Italia) Daniele Brombal (Università Ca' Foscari Venezia, Italia) Renzo Cavalieri (Università Ca' Foscari Venezia, Italia) Marco Ceresa (Università Ca' Foscari Venezia, Italia) Laura De Giorgi (Università Ca' Foscari Venezia, Italia) Beatrice Gallelli (Università Ca' Foscari Venezia, Italia) Franco Gatti (Università Ca' Foscari Venezia, Italia) Tiziana Lippiello (Università Ca' Foscari Venezia, Italia) Paolo Magagnin (Università Ca' Foscari Venezia, Italia) Federica Passi (Università Ca' Foscari Venezia, Italia) Nicoletta Pesaro (Università Ca' Foscari Venezia, Italia) Elena Pollacchi (Università Ca' Foscari Venezia, Italia) Sabrina Rastelli (Università Ca' Foscari Venezia, Italia) Guido Samarani (Università Ca' Foscari Venezia, Italia) Jacopo Scarin (Università Ca' Foscari Venezia, Italia)

## **Direzione e redazione | Head office**

Dipartimento di Studi sull'Asia e sull'Africa Mediterranea

Università Ca' Foscari Venezia

Palazzo Vendramin dei Carmini

Dorsoduro 3462

30123 Venezia

Italia

e-ISSN 2610-9042

ISSN 2610-9654



URL <https://edizionicafoscari.unive.it/it/edizioni/collane/sinica-venetiana/>

# **The Historian's Gaze**

Essays on Modern  
and Contemporary China  
in Honour of Guido Samarani

edited by  
Laura De Giorgi and Sofia Graziani

Venezia  
**Edizioni Ca' Foscari** - Venice University Press  
2023

The Historian's Gaze. Essays on Modern and Contemporary China in Honour of Guido Samarani  
edited by Laura De Giorgi and Sofia Graziani

© 2023 Laura De Giorgi, Sofia Graziani for the text  
© 2023 Edizioni Ca' Foscari for the present edition



This work is licensed under a Creative Commons Attribution 4.0 International License  
Quest'opera è distribuita con Licenza Creative Commons Attribuzione 4.0 Internazionale



Any part of this publication may be reproduced, stored in a retrieval system, or transmitted  
in any form or by any means without permission provided that the source is fully credited.

Qualunque parte di questa pubblicazione può essere riprodotta, memorizzata in un sistema di  
recupero dati o trasmessa in qualsiasi forma o con qualsiasi mezzo, elettronico o meccanico,  
senza autorizzazione, a condizione che se ne citi la fonte.



Scientific certification of the works published by Edizioni Ca' Foscari: the essays have received  
a favourable evaluation by subject-matter experts, through a double-blind peer review  
process under the responsibility of the Advisory board of the series. The evaluations were  
conducted in adherence to the scientific and editorial criteria established by Edizioni Ca' Foscari,  
using a dedicated platform.

Certificazione scientifica delle Opere pubblicate da Edizioni Ca' Foscari: i saggi qui pubblicati  
hanno ottenuto il parere favorevole da parte di valutatori esperti della materia, attraverso un  
processo di doppia revisione anonima, sotto la responsabilità del Comitato scientifico della  
collana. La valutazione è stata condotta in aderenza ai criteri scientifici ed editoriali di Edizioni  
Ca' Foscari, ricorrendo all'utilizzo di apposita piattaforma.

Edizioni Ca' Foscari  
Fondazione Università Ca' Foscari | Dorsoduro 3246, 30123 Venezia  
edizionicafoscari.unive.it | ecf@unive.it

1st edition October 2023  
ISBN 978-886-969-723-4 [ebook]  
ISBN 978-886-969-724-1 [print]

Cover design: Lorenzo Toso

The Historian's Gaze. Essays on Modern and Contemporary China in Honour of Guido Samarani  
/ edited by Laura De Giorgi and Sofia Graziani — 1st ed. — Venice: Edizioni Ca' Foscari, 2023. —  
viii + 208 p.; 23 cm. — (Sinica venetiana; 10). — ISBN 978-886-969-724-1.

URL <https://edizionicafoscari.unive.it/it/edizioni/libri/978-88-6969-724-1/>  
DOI <http://doi.org/10.30687/978-88-6969-723-4>

## **The Historian's Gaze**

Essays on Modern and Contemporary China  
in Honour of Guido Samarani

edited by Laura De Giorgi and Sofia Graziani

## **Abstract**

This volume brings together a group of historians of modern China and East Asia, who have shared with Guido Samarani the experience of studying China in the last thirty years. It represents a small tribute to a friend and colleague, whose outstanding research activities have greatly increased our understanding of Chinese modern and contemporary history. Inspired by Samarani's vast and multiple research interests, the essays collected in this volume weave together new interpretations and perspectives on the history and historiography of modern and contemporary China, covering a broad range of periods and topics, from imperial times to the contemporary age.

**Keywords** Twentieth century China. History of modern and contemporary China. China and the world. Revolutions. Chinese Nationalist Party. Chinese Communist Party.





## **The Historian's Gaze**

Essays on Modern and Contemporary China  
in Honour of Guido Samarani  
edited by Laura De Giorgi and Sofia Graziani

# **Table of Contents**

## **Introduction**

Laura De Giorgi, Sofia Graziani 3

## **What is 'Modern' China?**

### **Desperately Seeking for 'a' Birthday**

Federica Ferlanti 9

## **Foreign Concessions and Western Impact in the Late Qing Period: Historiographical Approaches and Political Interpretations**

Marina Miranda 25

## **Patterns and Trends of World History/Global History in the People's Republic of China: Reflections by Prof. Ge Zhaoguang**

Elisa Giunipero 39

## **China's Ethnic Relations in Historical Perspective: From the Qing to the People's Republic**

Yu Shen, Larry Shyu 51

## **Sun Yat-sen: A Life Beyond Symbols. A Semiotic Approach to Modernity**

Aglaia De Angeli 77

## **Gauging the Tide: The Rise of Nationalist China in Japan's Leading Newspapers, 1928-29**

Andrea Revelant 97

## **Forging the Nation Through Friendship: Nationalist China's Propaganda on Wounded Soldiers in the Early 1940s**

Laura De Giorgi 125

<b>Towards a New Political Order: Re-Establishing the Youth League after the Sino-Japanese War (1946-49)</b>	139
Sofia Graziani	
<b>The Two World Wars and China's Changing International Status</b>	155
Hongmin Chen	
<b>A 'Multi-Voice' Choir. Making Foreign Policy in Post-Maoist China</b>	167
Barbara Onnis	
<b>The Wisdom of Senses. Neo-Confucian Reflections on Cultural Body</b>	183
Paolo Santangelo	
<b>Authors' Bio</b>	203

## **The Historian's Gaze**

Essays on Modern and Contemporary China  
in Honour of Guido Samarani



### **The Historian's Gaze**

Essays on Modern and Contemporary China  
in Honour of Guido Samarani

edited by Laura De Giorgi and Sofia Graziani

# **Introduction**

**Laura De Giorgi**

Università Ca' Foscari Venezia, Italia

**Sofia Graziani**

Università di Trento, Italia

This volume brings together a group of historians of modern China and East Asia, based in Italy and abroad, who, as colleagues or former students, have shared with Guido Samarani the intellectual and human experience of studying China in the last thirty years and engaging in the development of the field. It has no ambition to reflect the vast range of research topics and interests Samarani has contributed to and to represent the whole community of scholars who have collaborated with him during his long career. It represents just a small tribute by some of them to a friend and colleague, whose outstanding research activities have greatly increased our understanding of Chinese modern and contemporary history, as well as inspiring and influencing students and academics active both in Italy and abroad.

In the last decades, the study of modern and contemporary China has widened its scope to include a vast variety of disciplinary approaches. The increasing availability of sources and the multiplication of perspectives have offered new pathways for research but also new challenges. Historians of China have been called to specialise but at the same time maintain and develop their capacity to look at China from wider chronological and geographical angles; they have been asked to read Chinese history from within, exploring the original sources in depth and at the same time considering the intertwining of the regional and global factors that have affected the dynamics of Chinese history in the last centuries.

The historical research of Samarani highlights all these challenges. As he puts it in his seminal book *La Cina contemporanea* (2017), the twentieth century has been a period of great transformations for China, a period when the political, social and cultural values that shaped the collective and individual lives of the Chinese people have been deeply changed by revolutions and modernisation at the intersection of local and global factors. These transformations have also implied significant changes in the ways in which the Chinese past has been investigated and conceptualized in light of the problems and opportunities of the contemporary age.

Samarani's prominent position as a widely recognised scholar at both the national and international levels grew from his intellectual and scholarly interests in the political history of twentieth-century China and his constant scientific commitment throughout his long academic career. During his 37 years of academic activities (1983-2020), he distinguished himself through his strong dedication to developing historical research on issues including problems of modernisation in the Republican period, the history of modern political thought from Sun Yat-sen to the People's Republic of China, the diplomatic and political relations between Italy and China, and finally contemporary China's foreign policy and world outlook. This is demonstrated by the quantity and quality of his scientific contributions (in Italian, English, Chinese, Japanese and German) as well as by several pioneering research projects that he has promoted and directed since 2003 as part of his constant commitment to the internationalisation of historical research on China in Italy.

These projects developed in the framework of a broad collaboration at the international level and opened new perspectives regarding the international dimension of Chinese contemporary history, leading Samarani to establish himself as a recognised authority in the study of China's relations with Italy in the European context of the twentieth century.

Samarani's major scientific contributions include an innovative study of China under the Chinese Nationalist Party (*Una modernizzazione mancata. Aspetti e problemi dello sviluppo capitalistico in Cina tra le due guerre*, 1988) and several articles on the history of the Chinese Nationalist Party's prominent intellectual and political personalities, such as Dai Jitao and Hu Hanmin. Later, in 2004, he published the first edition of *La Cina contemporanea*, the most important and comprehensive Italian book dedicated to the history of China in the twentieth century. This work was the outcome of twenty years of research and reflection on the political, cultural and economic transformation of China during the twentieth century. This research nourished Samarani's renewed interest in the ideological and political evolution of the Chinese Communist Party, which formed the basis for his and Sofia Graziani's book on the

history of the CCP (*La Cina rossa. Storia del Partito comunista cinese*, 2023). This book demonstrates how, after his retirement, Samarani has remained an enthusiast scholar keen to share his insights and research with our community.

Another field of great interest for Samarani is the history of the relations between Italy and China in the modern and contemporary periods. He was co-author, together with Laura De Giorgi, of a pioneering work on this topic (*Lontane, vicine. Le relazioni fra Cina e Italia nel Novecento*, 2011), as well as author of numerous ground-breaking studies on aspects of the Italian presence in China in the inter-war period and the 1950s, previously neglected by Italian and international history scholars. In the last ten years, Samarani has also co-edited books in Italian, English and Chinese on the history of relations between China and Europe during the Cold War.

Inspired by Samarani's vast and multiple research interests, and with the aim of acknowledging his role in the development of the study of Chinese modern and contemporary history in Italy and abroad, the essays collected in this volume weave together new interpretations and perspectives on the history and historiography of modern and contemporary China. They cover a broad range of periods and topics, from imperial times to the contemporary age, with most focussing on the modern and contemporary eras. The book opens with an essay by Federica Ferlanti on the notion of modernity and its meaning over time in relation to both historians' subjectivity and the nation- and state-building process in China. Historiographical and *longue durée* historical concerns also animate the following three essays: Marina Miranda's examination of the evolving Chinese academic and political discussion of the role of foreign concessions, Elisa Giunipero's introduction to World History/Global History in China and Larry Shyu and Yu Shen's overview of policies regarding national minorities in China's modern history, from the Qing to the People's Republic.

The changing political and cultural landscapes at the domestic level are at the centre of the four essays that follow, which present a number of case studies, beginning with Aglaia De Angeli's semiotic analysis of Sun Yat-sen as an emblem of modernity. The essay by Andrea Revelant addresses the representation of Nationalist China in Japan's leading newspapers, providing insights into Japanese public opinion and attitudes towards China in the late 1920s, while Laura De Giorgi's contribution focuses on nation-building and war propaganda in China during the War of Resistance against Japanese Aggression, with particular attention to the discourse on wounded soldiers. Sofia Graziani's essay focuses on the role of youth organisations (the Youth League) in the Chinese Communist Party's political strategy after the end of the Sino-Japanese War. The final section of the book consists of Chen Hongmin's and Barbara Onnis's contri-

butions, which address two different crucial themes in China's relations with the world, namely China's role in the international organisations born from the two world wars (the League of Nations and the United Nations), and the evolution of foreign policy-making processes and actors since the Deng era. The book closes with an essay by Paolo Santangelo on the senses in the Neo-Confucian philosophical tradition, which broadly reminds us of the importance of Sino-logical and textual approaches to Chinese history.

On the whole, the array of topics developed by the authors reflects the richness of approaches and interests that Samarani has sewn and developed in a continuous and rich exchange with colleagues in Italy and abroad. Through this small tribute, we would like to express our gratitude for his intellectual and academic work and for the support and inspiration that he has always offered and continues to offer, not only as an esteemed scholar but also as a dear teacher, colleague and friend.

### Guido Samarani's Main Publications

*Una modernizzazione mancata. Aspetti e problemi dello sviluppo capitalistico in Cina tra le due guerre.* Venezia: Cafoscarina, 1988.

*La Cina verso il 2000. Potere politico e trasformazioni economico-sociali.* Venezia: Cafoscarina, 1994.

*La pagoda e il grattacielo. La Cina tra eredità storica e modernizzazione.* Torino: Paravia, 1998.

"The Evolution of Italian Diplomacy During the Sino-Japanese War". Barrett, D.; Shyu, L. (eds), *China in the Anti-Japanese War, 1937-1945: Politics, Culture and Society.* New York: Peter Lang, 2001, 65-87.

(ed.). *The Asian Connection: Dynamics of Colonialism, Nationalism and Identity in East and South Asia, 1915-1945*, monogr. no., *European Journal of East Asian Studies*, 3(1). Leiden: Brill, 2004.

*La Cina del Novecento. Dalla fine dell'Impero ad oggi.* Torino: Einaudi, 2004. 2nd ed. *La Cina contemporanea. Dalla fine dell'Impero ad oggi.* Torino: Einaudi, 2017.

"La Cina e i mutamenti nella situazione internazionale nell'analisi di Dai Jitao (1911-1913)". Scarpari, M.; Lippiello, T. (a cura di), *Caro Maestro... Scritti in onore di Lionello Lanciotti per l'ottantesimo compleanno.* Venezia: Cafoscarina, 2005, 1029-36.

"Shaping the Future of Asia: Chiang Kai-shek, Nehru and China-India Relations During the Second World War Period". Centre for East and South-East Asian Studies Working Paper, Lund University, 11, 2005, 1-20.

(with De Giorgi, L.). *La Cina e la Storia. Dal tardo impero ad oggi.* Roma: Carocci, 2005.

"In Search of Chinese Identity in a Changing World: Dai Jitao's Articles in the Late Qing-Early Republican Period". Chou, L.; Guida, D. (eds), *A Passion for China: Essays in Honour of Paolo Santangelo in His 60th Birthday.* Leiden: Brill, 2006, 329-37.



- “Alle origini di Bandung: il viaggio di Chiang Kai-shek in India (febbraio 1942)”. *Rivista degli Studi Orientali*, 78(3/4), 2007, 429-38.
- “Il massacro di Nanchino tra storia e storiografia”. Procacci, G.; Silver, M.; Bertucelli, L. (a cura di), *Le stragi rimosse. Storia, memoria pubblica, scritture*. Milano: Unicopli, 2008, 81-97.
- (with De Giorgi, L.). “Guomin zhengfu shiqi de Zhong Yi guangxi shi: Yidali wenshiliao jieshao” 國民政府時期的中義關係史——義大利文史料介紹 (Italian Sources on the History of Sino-Italian Relations during the Nationalist Era). *漢學研究通訊* (Newsletter for Research in Chinese Studies), 28(4), 2009, 50-3.
- (with Scarpari, M.) (a cura di). *La Cina*. Vol. 3, *Verso la modernità*. Torino: Einaudi, 2009.
- Cina, ventesimo secolo*. Torino: Einaudi, 2010.
- “An Historical Turning Point: Italy’s Relations with China Before and After 8 September 1943”. *Journal of Modern Italian Studies*, 15(4), 2010, 590-602.
- (with De Giorgi, L.). *Lontane, vicine. Le relazioni fra Cina e Italia nel Novecento*. Roma: Carocci, 2011.
- “Italians in Nationalist China (1928-1945): Some Case Studies”. Brady, A.M.; Brown, D. (eds), *Foreigners and Foreign Institutions in Republican China*. London: Routledge, 2012, 234-50.
- “L’Italia e gli italiani in Cina dopo l’8 settembre 1943”. *Storia & Diplomazia*, 1(2), 2014, 15-30.
- “The Italian Presence in China: Historical Trends and Perspectives (1902-1947)”. Marinelli, M.; Andornino, G. (eds), *Italy’s Encounters with Modern China: Imperial Dreams, Strategic Ambitions*. New York: Palgrave Macmillan, 2014, 49-66.
- (with Meneguzzi Rostagni, C.) (a cura di). *La Cina di Mao, l’Italia e l’Europa negli anni della Guerra fredda*. Bologna: il Mulino, 2014.
- (with Graziani, S.). “Yidali gongchandang yu Zhonghua renmin gongheguo: zhengzhi lianxi yu jiaoliu (1949-1965)” 意大利共产党与中华人民共和国: 政治联系与交流 (1949-1965) (The Communist Party of Italy and People’s China: Political Ties and Exchanges [1949-1965]). *Lengzhan guojishi yanjiu* 冷战国际史研究 (Cold War International History Studies), 19-20, 2015, 5-29.
- (with De Giorgi, L.). “Guomindang (1912-1949)”. *Oxford Bibliographies Online*, 2016. <https://dx.doi.org/10.1093/obo/9780199920082-0138>.
- “Le guerre in Asia nel Novecento: l’esperienza della Cina e dell’Asia orientale (1985-1945)”. Detti, T. (a cura di), *Le guerre in un mondo globale*. Roma: Viella, 2017, 155-70.
- “Ouzhou yu Yidali diqu youguan Jiang Jieshi ji qi shidai de yanjiu” 歐洲與義大利地區有關蔣介石及其時代的研究 (Studies on Chiang Kai-shek and His Times in Europe and Italy). *Aomen ligong xuebao* 澳門理工學報 (Journal of Macao Polytechnic University), 20, 2017, 194-9.
- (with De Giorgi, L.) (eds). *Chiang Kai-shek and His Time: New Historical and Historiographical Perspectives*. Venezia: Edizioni Ca’ Foscari, 2017. <http://doi.org/10.14277/978-88-6969-126-3>.
- La rivoluzione in cammino. La Cina della Lunga Marcia*. Roma: Salerno Editrice, 2018.
- “La Rivoluzione sovietica e il Partito comunista cinese”. *Contemporanea*, 21(2), 2018, 277-83.
- (with Meneguzzi Rostagni, C.; Graziani, S.) (eds). *Roads to Reconciliation: People’s Republic of China, Western Europe and Italy During the Cold War Period (1949-1971)*. Venezia: Edizioni Ca’ Foscari, 2018. <http://doi.org/10.30687/978-88-6969-220-8>.
-

- “History and Memory: Italian Communists’ Views of the Chinese Communist Party and the PRC During the Early Cold War”. Schaufelbuehl, J.M.; Wyss, M.; Zanier, V. (eds), *Europe and China in the Cold War: Exchanges Beyond the Bloc Logic and the Sino-Soviet Split*. Leiden: Brill, 2019, 134-50.
- (a cura di). “Nuovi approcci alla storia delle relazioni internazionali della Repubblica Popolare Cinese”, monogr. no., *Rivista italiana di storia internazionale*, 2, 2019.
- “Italian Diplomats in China During the Republican Era (1912-1949)”. Schatz, M.; De Giorgi, L.; Ludes, P. (eds), *Contact Zones in China: Multidisciplinary Perspectives*. Berlin; Boston: De Gruyter, 2020, 70-80.
- (with Graziani, S.). *La Cina rossa. Storia del Partito comunista cinese*. Bari: Laterza, 2023.

## The Historian's Gaze

Essays on Modern and Contemporary China  
in Honour of Guido Samarani

edited by Laura De Giorgi and Sofia Graziani

# What is 'Modern' China? Desperately Seeking for 'a' Birthday

Federica Ferlanti

Cardiff University, UK

**Abstract** Historians have been obsessed with pinpointing the birth of modern China. However, what do we (historians) look for when we try to trace its birth? And more importantly, how do we understand the term 'modern' and by extension 'modernity'? Has its meaning changed over time? This essay addresses these problems by focussing on two main aspects. The first aspect concerns Chinese modernity in relation to historians' subjectivity and periodisation. The concept of modern and modernity is not set in stone and what is modern depends on who is asking the question, with context, nationality/ethnicity and gender accounting for historians' subjectivity. One should also take into account that new perspectives are gained due to the passage of time and the concept of what makes China modern at any given point shifts accordingly. The second aspect is the nation- and state-building process. The changing relationship between the individual and the state seems a good vantage point from which to explore modernity. From citizenship to mass politics, the essay draws on different examples to illustrate the main trends that emerged and bedded in during the Republican period, and beyond, and explain why we might (or might not) consider them markers of modernity.

**Keywords** Hybrid modernities. Subjectivity. Periodisation. Nation and state-building. Modern citizen.

**Summary** 1 Historians' Subjectivity and Chinese Modernity. – 2 The Individual and the Modern State. – 3 Conclusions.

For many years, historians have credited the interaction with the West for the momentous changes that took place in China in the nineteenth and twentieth centuries. The discussion of the colonial input in China's modernity, or any other country for that matter, is not a moot debate; to this day 'colonial modernity' and 'modernity' are often considered



### Sinica venetiana 10

e-ISSN 2610-9042 | ISSN 2610-9654

ISBN [ebook] 978-88-6969-723-4 | ISBN [print] 978-88-6969-724-1

#### Peer review | Open access

Submitted 2022-07-26 | Accepted 2022-12-07 | Published 2023-10-11

© 2023 Ferlanti | © 4.0

DOI 10.30687/978-88-6969-723-4/001

interchangeable concepts, and this approach encompasses the whole of Asian history.<sup>1</sup> Cohen's China-centred history marked a paradigmatic shift and paved the way for the analysis of the multiple factors and causes contributing to underpinning China's experience of imperialism (Cohen 2010). The same goes for other Asian countries. Stephens noted that the association of Korean modernity with Japanese colonialism and the periodisation of the Chosŏn era promoted a unilateral idea of modernisation process divorced from locality, and this could not be further from reality, as the "precolonial reform projects" were instrumental to the Japanese colonial building (Stephens 2019, 111). Furthermore, the association of colonialism with modernity skewed the historiographical debate since "the collective focus on modernity has arguably limited the scope of historical enquiry to topics that fit within chosen definitions of modernity" (110).

Historians have also reframed the approach to Asia's treaty ports history. Considered outposts of colonial powers and proof of the asymmetrical relation between foreign countries and those upon which the opening of ports was imposed, recent historiography has convincingly researched the links among Asian treaty ports, the development of indigenous trade networks, for example frontier trade, and, more broadly, previously overlooked relationships across Asia (Hamashita 2001; Murakami 2013; Lin 2017; Stephens 2019). Hamashita argued that between 1830 and the 1890s Asia experienced an "era of negotiation" (2001, 59). He focussed on the intra-Asian relationship among the treaty ports (treaty port diplomacy) and considered it distinct from Western diplomacy's bilateral framework: for instance, China and Korea harmonised treaty port trade with existing tribute trade and internal and frontier trade. Hence, a multilateral approach to treaty port Asia unveiled interconnected dynamics and recast the relationship between modernity and colonialism (Hamashita 2001, 60, 63, 65-74, 82).<sup>2</sup>

As for Chinese modernity, historians have long been obsessed with pinpointing the birth of modern China. However, what do we (historians) look for when we try and trace its birth? And more importantly, how do we understand the term 'modern' and by extension 'modernity'? Has its meaning changed over time? These questions are long-standing, but there are reasons why we should keep asking them: modernity is a fluid and mutable concept, hence it requires to be redefined by each generation of historians; in addition, the way

**1** The interest in colonial modernity was piqued by the readings done in preparation for the online workshop organised by Drs Tsai Weipin (Royal Holloway, UK) and Donna Brunero (National University of Singapore) on 17 September 2021 on trade and tariffs in Asia. The Author would like to thank the organisers and the participants for the inspirational discussion.

**2** See also Cohen 2010, XLV-XLVI for a discussion of Hamashita's argument.

in which these very questions are answered tells a great deal about the historians' approach to Chinese history. Modernity, understood as a drive towards something 'other', was the result of a process of hybridisation, in which assimilation, interpretation and readaptation all cohabited. This is not to say that the relationship with the 'West' was not significant; however, the concept of 'hybrid modernities' (intentional plural), is a better fit for encompassing China's history and its foreign interactions.<sup>3</sup>

This essay addresses these conundrums by discussing two modernity-related issues: historians' subjectivity in studying Chinese modernity, and the modern state and the individual. The first part explores Chinese modernity in relation to historians' subjectivity and the use of periodisation. It argues that the concept of modern and modernity is not set in stone and what is modern depends on who is asking the question with context, nationality and/or ethnicity, and gender accounting for the historians' subjectivity. Knowing when and where this question is asked is also essential; as new perspectives are gained due to the passing of time, the concept of what makes China modern at any given point shifts accordingly. In addition, Chinese contemporaries may entertain ideas of modernity specific to the geographical area in which they live and work. The most obvious differentiation is between urban and rural areas, but here I shall use the concepts of 'peripheral' and 'rural' modernities to highlight the complexities of modernity.

The second part discusses modernity from the vantage point of the nation- and the state-building process, more specifically, the changing relationship between the individual and the state from citizenship to mass politics. In China, the enduring presence of these themes across different times and political regimes attest to this topic's significance. The essay draws on examples and illustrates the main dynamics that developed and bedded in during the Republican period, and explains why we might, or might not, consider these experiences markers of modernity.

The essay concludes that the discovery of modern China is an invention. Just like the discovery of America by Colombo was a non-discovery, because America had been there all along, Chinese modernity is the result of modernities and indigenous values shaped by the interactions with the rest of Asia, and countries west of China. Interrogating ourselves about modernity's building blocks in Asia in the age of colonialism and post-colonialism helps probing and resisting the lures of periodisation. Equally, at a time when China's

---

**3** I came up with this term independently, but I do not claim to have coined it. A quick search returned two monographs which use this concept, and both focus on the relationship between architecture and colonialism: Morton 2000; Padua 2020.

movements across East Asia and Southeast Asia are watchfully scrutinised by both China's neighbours and countries far afield, the experience of the past can shed light on current attitudes, perceptions, and overtones.

## 1 Historians' Subjectivity and Chinese Modernity

What do historians have in mind when we try and trace the birth of modern China? And more importantly: what do we mean when we use the term 'modern' (Wenlin 4.0, 2011)?<sup>4</sup> The answer could be the same of 'what is beauty?', with beauty being 'in the eye of the beholder'. In other words, we are mindful of personal inclinations and preferences to define beauty, and even though we might disagree on the degree of beauty of an object or a person, there is ordinarily some collective consensus because time and cultural influences are key factors in reaching a definition. Nonetheless, even though we might reach consensus of what is modern and modernity at a specific point in time, definitions do vary.

The perception of modernity as an ever-changing concept is predicated on the diversity and subjectivity of the historical debates: what historians might consider modern and where they would place the birth of modern China are all subjective matters. Questions about modernity are worth asking because they prompt historians to come up with a definition and the more definitions we have, the more nuanced and aware we become. Historians are shaped by the social context in which they conduct themselves as individuals and develop and articulate their ideas, and so does their concept of modernity. 'My' idea of China's modernity was influenced by my upbringing in Europe in the second half of the twentieth century, my life experience and perhaps gender. When my interest in modern Chinese history developed, I was acutely aware of Italy's similarities with China during the nineteenth and twentieth centuries: it was mostly an agrarian economy characterised by so-called 'delayed industrialisation' process and strong social and nationalist movements. It is a possibility that my interest in state- and nation-building, as well as mass mobilisation, developed from a familiarity with these topics.

---

<sup>4</sup> The etymology of 'modern' in Chinese is a tell-tale sign of the nuances embedded in the word: "modern [ˈmʊdərən] 1. xiàndài de 现代的; jìndài de 近代的 现代的 xiàndài de 现代的; jìndài de 近代的; jìndài de xiàndài de 现代的; jìndài de 近代的 近代的 xiàndài de 现代的; jìndài de 近代的 xiàndài de 现代的; jìndài de 近代的 2. xīnshì de 新式的; shí máo de 时髦的 fashionable; mó dēng 摩登 <loan> modern; fashionable" (Wenlin 4.0, 2011). The analogy 'modern-fashionable' is fascinating: what is fashionable at a certain point in time is usually new, and what is new is more often than not considered modern, particularly by young people whom by definition have a shorter historical memory.

The influence of time and cultural trends should also be considered. Historians tend to ask similar questions and historical interpretations rise and swirl. For instance, in the 1990s the topics of state-building, civil society, nationalism, and internationalisation became key research areas (Wakeman 1993). Very likely, the fall of the Berlin Wall and the widespread application of the World Wide Web enhanced our perception of interconnectedness and globalisation. In the 1990s, the debate about Chinese modernisation during the Republican period was all the rage and the book *China's Quest for Modernization: A Historical Perspective* (Wakeman, Wang 1997) marked an important development for two reasons: first, it made clear that modernisation could only be understood and defined in 'historical perspective' and by encompassing a breadth of topics; and second, that the chronology of modernisation was comprehensive of late imperial China. In other words, it would be unwise to try and single-out Republican China as the cradle of modernity, and continuities across time and space may be more useful indicators for exploring modernity.

However, relinquishing periodisation is not that straightforward, and would that be even a wise move? Periodisation is a necessary evil whose pitfalls are well understood, but there are also gains to be made from it. How we divide up and designate time-periods is a convention often shaped by whom is in power. The one-party state system complicated matters further in the People's Republic of China and Taiwan, but in essence power and periodisation go hand in hand everywhere. Periodisation prompts historians to question who was driving what narratives for the period they examine and why. It is this kind of approach that ultimately makes a more nuanced understanding of history possible. For instance, the Guomindang (Nationalist Party) and the Communists articulated their notions of the state *vis-à-vis* modernity, and so did the late Qing's government. If one would like to have the measure of the process entailing the crafting of the modern state, then this purpose would be best served by exploring the topic across different time-periods: the continuities between the late Qing state, its reforms, and the Republic are a case in point (Horowitz 2003). On the other hand, we must be conscious that the political parties and governments neither represented faithfully, nor summed up attitudes towards modernities across the whole of China. To account for that, we should examine the relationship between geography and modernity.

Understanding Chinese modernity is intimately connected to its geography. Chinese cities have been at the centre of historical enquiry, with Shanghai being considered the torchbearer for modernity. However, there is more to Chinese cities than the treaty ports and capitals (Nanjing and Beijing) and we should root for the 'not-so-cool' cities. In addition, change did not stop at the city walls and there is a case to be made for granting rural modernity equal standing. Approaching

modernity by framing these three geographical points of contact on the one hand enables us to showcase diversity, and on the other sets the stage for the exploration of individual modernity in the next section.

Shanghai was the crucible for Chinese and foreign modernities. It was a treaty port risen from humble beginnings, where multiple forces were at play and moved fast during the late Qing period and Republican China: trade and commerce, the interaction between Chinese and foreign businesses, workers from the rural areas, printing business, transportation, schools and universities, and new trends in consumption and culture, just to name but a few. Shanghai modernity, Yeh argued, was the result of a unique mix which was specific to this city and different from the rest of China (Yeh 1997). For this reason, Shanghai cannot speak for the rest of China and the exploration of the not-quite-so glamorous cities would certainly yield different conclusions, but how so?

Cities such as Nanchang and Lanzhou show that various modernities were in action and proceeded at different speeds. In Nanchang, the provincial capital of Jiangxi province, changes to the urban landscape and transportation came thick and fast after the establishment of the Nanjing government. Specific political developments facilitated urban regeneration projects: from mid to late 1927, the province became the hiding site for the Communists and further down the line, in 1931, the headquarters of the First Chinese Soviet Republic. Chiang Kai-shek moved its military headquarters to Nanchang in the early 1930s and this presence changed both urban dynamics and landscape: the reorganisation of the city-planning and the upgrade of sanitation and transportation were certainly linked to Chiang's presence in town (Ferlanti 2013). Lanzhou, the provincial capital of Gansu province in the northwest of China, was more remote than Nanchang geographically and, around the same time, it experienced large-scale changes. Peripheral cities, according to Strand, were in fact nodal points of exchange based on ongoing relationships among cities of different sizes and importance, and challenged the dichotomy of local vs global and rural vs urban. For instance, the employment of urban planners, engineers, bureaucrats matched the expansion of the state through "the import of new technologies and organizational forms" (Strand 2000, 107-8, 125). These middle-ranking urban centres demonstrate that diverse experiences of modernities existed. They proceeded at different speed depending on the set of local conditions, geographical or otherwise, and all together produced unique blends of modernity. Nonetheless, these phenomena were interconnected. To begin with, Shanghai modernity was not bottled up and one-sided, and ramifications across urban and rural China could be traced through the movement of people, such as migrant workers, and the circulation of ideas through newspapers and periodicals printed in the city (Yeh 2000, 1-16). Dynamics whose beneficial effects,



incidentally, current insular policy-makers across the world seem to be ignorant of. In other words, modernity and interconnectivity were features of rural China too.

Far from being cut off from the changes that were shaking and stirring cities small and large, rural China was not a passive recipient of the transformations taking place elsewhere, but took them in, readapted and ultimately shared them out again. In addition, the exchange went in both directions. China's rural revolution is a classic example of just that: long before the Nationalists and the Communists cast eye on the revolutionary potential of the rural masses with the Nationalist Party's Peasant Movement Training Institute and Peng Pai's Hailufeng Soviet in the 1920s, the countryside had experienced collective organised protests and violent takeovers. Indeed, some of these were linked to developments far afield, such as the changes in the economy in the South of China, the wider circulation of goods beyond the treaty ports and foreign ideas; but others were rooted in local circumstances, for instance, the scarcity of good land to till during the late Qing period which combined with loosely Christian-inspired ideas produced the Taiping rebellion (Gao 2016; Thaxton 1997; Wakeman 1997; Rowe 2009). One could argue that Communism, a foreign import, by spreading to the rural areas delivered cultural, social and economic modernities, but the process was by its very nature fragmented and so were the modernities that travelled with it. Communism took hold, when and where it did, through a process of sifting and adaption in which the peasants and local society partook. The analysis of the Land Law in 1931, the Land Investigation Movement in 1933-34, and the land policy during the Yan'an period reveals that each of them marks different approaches to the land question. These were not based on academic discussions, but had to take into consideration multiple actors' responses (as social classes and individuals), not to mention the local geography and economy. For example, the relative tolerance towards the middle peasants shown in 1931, at the dawn of the soviet experience in Jiangxi, was eroded by the acceleration of the land confiscation and fines imposed throughout 1933-34, and then rural policies were remodulated during the Yan'an period, after the fall of the Central Soviet and under the changed circumstances of the war against Japan (Schram 1992, 822-5; Saich, Yang 1994, 602-3; Goodman 2000). The Communist revolution stretched long and wide, and through cycles of indigenisation, it scattered many modernities across China.

Two considerations follow from the above. The first would be that the divide between modern and traditional pertaining to urban and rural China is artificial and often dismissive of the latter's capacity to generate its own blend of modernity. The second would be that the dynamic relationship between urban and rural China, and the liminal spaces in between neither rural nor urban, could be approached more

beneficially from the perspective of 'networks of modernity'. Just like highways and local roads, there were pathways of modernities that criss-crossed the country at different speed and degree of traffic, resulting in several combinations. Through local histories, historians can map these pathways and explore points of contact, and in turn can achieve a more thorough understanding of modernity. This approach, however, is not without its drawbacks, namely the analysis of places and communities risks obscuring individual experiences. The next section tries to address this issue by focussing on individual modernity, and does so by exploring the relationship between the individual and the modern state.

## 2 The Individual and the Modern State

Historians did not invent the concept of Chinese modernity. Chinese contemporaries grappled with this same issue and analysed and debated at length modernity and China's path to modernisation. Arguably, what Chinese citizens perceived as being modern in the early Republican period was as subjective as the historians' approaches. But contemporaries' perception of social changes and attitudes can bring us closer to defining Chinese modernity, and much can be understood by observing what they embraced, resisted, or left them nonplussed.

Nation- and state-building and individual interactions with the state are central themes of modern China. The latter was an integral part of dynastic China too, but we can concur that the shift from the imperial subject to the Republican citizen was momentous and was perceived as an ingress into modern China. However, was it radical or even unforeseen? Not quite so. The act of becoming modern was not like turning a tap on and off and was nurtured by ideas and practices all vying for attention and not necessarily new, which then became prevalent depending on the context. As for the individual, debates over the concept of 'citizenship' and what meant to be and become a modern citizen evolved over time and certainly we cannot simply credit the Republic for it.

Liang Qichao's essays about the "new citizen", his rethinking of the empire as a "citizen-state" and his definition of "the legitimate role of *si* [the individual] as the basic of civic participation" (Zarrow 2012, 76-7) give the sense of the depth of intellectual and political change that was taking place before the Republic came into being. These concepts stemmed from an intellectual debate whose scholarly roots were planted deeply into the imperial system and radical Confucianism (Zarrow 2005, 12-29). It was not a lofty debate, and Liang's understanding of the new citizen was more practical than philosophical, as Fung, following in Zarrow's footsteps, explained:

[Liang's] new citizens (*xin min*) were not subjects or commoners but people exercising rights, especially the right of political participation. [...] His new citizens were empowered as members of a political community and organic society, with a consciousness of their rights, actively participating in the determination of China's destiny in an age of imperialism and in a world of competing nation-states. (Fung 2006, 456-7)

Hence, the new citizen required a nation-state, or as Liang noted a "citizen-state" (Zarrow 2012, 76-7), in which the right of political participation would be recognised. It follows that the nation (or citizen-state) could not exist without the new citizen and the seeds of the modern state were planted long before the Republic.

The newly established Republic, however, can be credited for unleashing the new citizen and modern citizenship's potential. State-building and education were chosen channels for achieving such an outcome, and the attempt of teaching modern citizenship was systematic during the Republican period (Culp 2007). In 1912 Cai Yuanpei, in his capacity of Minister of Education, explained how education could shape Chinese citizens. He concluded that China needed both a "military education for citizens" and a "moral education for citizens [...] because strong neighbours are all oppressing us, we have to plan hastily for self-protection"; also, "after a revolution by the militarists, it is hard to guarantee that there will not be a period when the militarists will wield political power" (Teng, Fairbank 1954, 235-6). The "military education for citizens", Cai admitted, was a legacy of the Qing dynasty, but given the international situation it could not be disregarded; it combined Confucian ethical principles with the principles that had inspired the French Revolution (235-6). Even though Cai's Republican ideas of citizenship were articulated through traditional practices and values, the resulting values were not necessarily at odds with modernity.

Both Liang and Cai's ideas show that discussions about the citizen cannot be separated from the context in which the citizen conducted itself. Despite the patent continuities with the past, the Republic set a novel direction of travel, and during the early years the nation- and state-building process proceeded almost hand in hand. One could consider Yuan Shikai's state-building efforts confined only to the state, however it was the state that oversaw the shaping up of citizens. The "making of the Republican citizen" was a long process that was kept on the state agenda for many years to come, and the objective was to mould a citizen that would identify with and be loyal to the new state (Harrison 2000). Even if these phenomena were not necessarily original, the nation- and the state-building process, and the citizens' education and modernity came together in the early years of the Republic.

It was in the interaction between the modern state and the individual that collective and individual modernities interfaced. The Republic was the outcome of a revolution, the Xinhai Revolution, and chronologically the beginning of a new era. In addition, the state fostered the idea that the Republic was a break with the past and promoted modern attitudes and behaviours across Chinese politics and society. Some were superficial, others more consequential: pictures of the Nanjing Provisional Government show officials sporting short hair and western clothing at its inauguration (*Zhongguo renmin zhengzhi xieshang huiyi Jiangsu weiyuanhui banggongting* 2001, 62), and citizens attended public ceremonies to celebrate the newly minted Republic with a National Day on the Double Tenth (Harrison 2000, 49-91). The use of national flags in public ceremonies and schools, and the sharing of behaviours, such as social etiquette with modern greetings and customs such as clothing, came to define the Republican citizen and were identified as markers of modernity (Harrison 2000, 49-91). The extent to which the change of regime and fashion statements of officials were genuine markers of modernity is another matter, as we ought to differentiate between perception, representation and conforming with the latest fashion. Nonetheless, to the wider population who were neither involved in the decision-making process nor acquainted with intellectual debates about the modern citizen, the sight of compatriots who were wearing unfamiliar clothes and changed flags at ceremonies was indeed a new spectacle. Public displays and official ceremonies were also in line with the reconfiguration of the public space, which was influenced by the ways space was planned by municipal administrations or spontaneously assigned to specific uses (e.g. parks, factories, and the Bund, to name a few), and the new ways in which it was enjoyed by the citizens (Tsin 1999). In other words, modernity went beyond the act of building the state and adopting national symbols, and promoted behavioural changes while reconfiguring the space the individuals inhabited. But how did collective perceptions of modernity and expectations of (some) individuals manage to form and circulate across Chinese society and beyond urban China? The answer, historians argue, is through education.

Education in the Republican period was instrumental in articulating contemporary notions of modernity. The debate about modern education fed from a multitude of contributors and the introduction of modern curricula in schools across China and in rural areas affected attitudes towards change and seeded the notion of modernity beyond school gates. Historians have written extensively about the implications of the overhaul of post-1912 Chinese education for the nation and state-building project, and for students and women (Culp 2007; VanderVen 2012; Bailey 2007). A crucial aspect was also the widening access to the profession of teachers and the expansion of rural

schools, all of which contributed to disseminating ideas of modernity across China for over three decades (Liu 2009; Cong 2007). The setting up of normal schools and colleges eased late Qing licentiates and higher degree holders into the teaching profession, as they were given preference in the application process, or were selected specifically by the new school system introduced between 1902 and 1905 (Cong 2007, 38-9, 44). Furthermore, the intake of a younger generation, who had been trained in the new school system since the late Qing period, and the expansion of the rural school networks consolidated modern curricula and contributed to the spreading of revolutionary ideas at county level and below (Averill 1987, 285-6; 2007, 14-16). Over time, the propagation of schools in rural areas widened the access to education for students and teachers of rural origins, a trend that grew during the late 1920s and 1930s (Liu 2009, 577-9, 584-5). Basically, not only did the progressive overhaul of education driven by the literate élites change the educational system and promoted social mobility, but also popularised ideas and perceptions of modernity across China. This is not to say that these ideas bedded in the system homogeneously, as time and geography must be also considered.

The perception of modernity by contemporaries is hugely significant for defining modernity. For instance, although the historiography has long dismissed the idea of the May Fourth mobilisation as the starting point for Chinese modernity, it was instantly credited with marking the birth of modern China. Its association with modernity was perhaps so pervasive, I suggest, also because it projected an idea of modernity and behaviours that foreigners were familiar with. John Dewey, the reputed academic, philosopher and educationist, on witnessing the ongoing student protests in Beijing in June 1919 remarked the novelty of girls' participation in the street protests and argued that "we are witnessing the birth of a nation" (Dewey, Dewey 1920, 7). But how were the 1919 student protests different from the rallies and boycotts which took place across China between January and June 1915 in response to the Twenty-One Demands from Japan? In 1915, overseas and Chinese students, citizens' associations, Chambers of Commerce, shopkeepers etc., all took to the streets and carried out boycotts of Japanese goods, and one can even observe the setting up of a National Salvation Fund in Shanghai supported by business and bankers (Luo 1993, 297-309). Why were those protests not sufficiently 'modern' and 'national'? On what grounds can one take the position that 1915, to paraphrase Dewey's words, did not mark the birth of modern China?

There are in fact no grounds, unless we reason that perhaps the May Fourth Incident and the generation that came to be defined by it were on the winning side and had the chance to tell the story and to do so very loudly from 1949 onwards. This is not to say that the story they told was unsound, but it is worth noting that the May Fourth generation

of revolutionaries who entered the domain of mass politics by joining the Chinese Communist Party and the Nationalist Party would not have been able to achieve as much as they did without the spadework of the preceding generation, the late-Qing generation (Ferlanti 2020). The historiography has come to a nuanced appraisal which compensates the Chinese Communist Party's narrative of the May Fourth Movement. However, its enduring prominence reinforces the idea that the birth of modern China is to be found in the Republican period.

### 3 Conclusions

This essay has explored the many ways in which historians and Chinese contemporaries understood and articulated Chinese modernity. It argues that the concept of Chinese modernity is an invention predicated on the sum of historical subjectivities and contemporaries' experiences of modernity. I drew attention, instead, to the existence of many and often competing modernities which developed across China, and argued that concepts such as 'hybrid', 'peripheral' and 'rural' modernities are a better fit to define the relationship between China and modernity during the Republican period. While Republican China encompassed individuals and society whose behaviours, interactions and characteristics we may regard as modern, choosing the Republic's establishment to mark the birthday of the modern state is tricky: we are aware of how things ended up with Sun Yat-sen handing over the Republic to Yuan Shikai, a remarkably non-modern looking leader, and the Republic ceasing to function as a national institution in the space of just a few years. To these days, the outset of the Republic is generally dealt with quickly by historians, and the birth of modern China is often associated with the 1919 May Fourth Incident and Movement. What we can perhaps agree upon is that the debates and dynamics that characterised the late nineteenth century and the early Republican period, the May Fourth Movement, the Northern Expedition, China and the West, and the Nationalist and the Communist revolutions etc., each embodied multiple modernities which originated and developed in different places and reached across China and beyond.

## Bibliography

- Averill, S.C. (1987). "Party, Society, and Local Élite in the Jiangxi Communist Movement". *The Journal of Asian Studies*, 46(2), 279-303. <https://doi.org/10.2307/2056015>.
- Averill, S.C. (2007). "The Cultural Politics of Local Education in Early Twentieth-Century China". *Twentieth-Century China*, 32(2), 4-32. <https://doi.org/10.1353/tcc.2006.0003>.
- Bailey, P.J. (2007). *Gender and Education in China: Gender Discourses and Women's Schooling in the Early Twentieth Century*. London: Routledge.
- Cohen, P.A. (2010). *Discovering History in China: American Historical Writing on the Recent Chinese Past*. New York: Columbia University Press.
- Cong, X. (2007). *Teachers' Schools and the Making of Modern Chinese Nation-state, 1897-1937*. Toronto: University of British Columbia Press.
- Culp, R.J. (2007). *Articulating Citizenship: Civic Education and Student Politics in Southeastern China, 1912-1940*. Cambridge: Harvard University Press.
- Dewey, J.; Dewey, A. (1920). "Peking, June 1, 1919". Lawrance, A. (2004). *China since 1919: Revolution and Reform: A Sourcebook*. London: Routledge, 7.
- Ferlanti, F. (2013). "City-Building, New Life and the 'Making of the Citizen' in 1930s Nanchang". So, B.K.L.; Zelin, M. (eds), *New Narratives of Urban Space in Republican Chinese Cities: Emerging Social, Legal and Governance Orders*. Leiden: Brill, 45-64.
- Ferlanti, F. (2020). "Educators and Power Brokers: Political Mobilization and Violence in Wannian County, Jiangxi Province, 1926-1935". *Twentieth-Century China*, 45(3), 227-46. <https://doi.org/10.1353/tcc.2020.0023>.
- Fung, E.S.K. (2006). "The Idea of Freedom in Modern China Revisited: Plural Conceptions and Dual Responsibilities". *Modern China*, 32(4), 453-82. <https://doi.org/10.1177/0097700406290473>.
- Gao, Y. (2016). "Revolutionary Rural Politics: The Peasant Movement in Guangdong and Its Social-Historical Background, 1922-1926". *Modern China*, 42(2), 162-87. <https://doi.org/10.1177/0097700415618357>.
- Goodman, D.S.G. (2000). *Social and Political Change in Revolutionary China: The Taihang Base Area in the War of Resistance to Japan, 1937-1945*. Lanham: Rowman & Littlefield.
- Hamashita, T. (2001). "Tribute and Treaties: East Asian Treaty Ports Networks in The Era of Negotiation, 1834-1894". *European Journal of East Asian Studies*, 1(1), 59-87. <https://doi.org/10.1163/157006102775123030>.
- Harrison, H. (2000). *The Making of the Republican Citizen: Political Ceremonies and Symbols in China, 1911-1929*. Oxford: Oxford University Press.
- Horowitz, R.S. (2003). "Breaking the Bonds of Precedent: The 1905-6 Government Reform Commission and the Remaking of the Qing Central State". *Modern Asian Studies*, 37(4), 775-97. <https://doi.org/10.1017/S0026749X03004025>.
- Lin, Y. (2017). "Continuity and Breakdown: Taiwan's Customs Service during the Japanese Occupation, 1895-1945". *The International Journal of Maritime History*, 29(4), 855-74. <https://doi.org/10.1177/0843871417726967>.
- Liu, C. (2009). "Prometheus of the Revolution: Rural Teachers in Republican China". *Modern China*, 35(6), 567-603. <https://doi.org/10.1177/0097700409337249>.

- Luo, Z. (1993). "National Humiliation and National Assertion: The Chinese Response to the Twenty-One Demands". *Modern Asian Studies*, 27(2), 297-319. <https://doi.org/10.1017/s0026749x00011501>.
- Morton, P.A. (2000). *Hybrid Modernities: Architecture and Representation at the 1931 Colonial Exposition*. Paris; Cambridge (MA): MIT Press.
- Murakami, E. (2013). "A Comparison of the End of the Canton and Nagasaki Trade Control Systems". *Itinerario*, 37(3), 39-47. <https://doi.org/10.1017/s0165115313000806>.
- Padua, M.G. (2020). *Hybrid Modernity: The Public Park in Late 20th Century China*. New York: Routledge.
- Rowe, W.T. (2009). *China's Last Empire: The Great Qing*. Cambridge; London: Belknap.
- Saich, T.; Yang, B. (eds) (1994). "D. 15 Order of the Central Government of the Chinese Soviet Republic on Land Investigation (1 June 1933)". *The Rise to Power of the Chinese Communist Party: Documents and Analysis*. New York: M.E. Sharpe, 602-3.
- Schram, S.R. (ed.) (1992). "Land Law of the Chinese Soviet Republic (December 1, 1931)". *Mao's Road to Power: Revolutionary Writings: 1912-1949*. Vol. 4, *The Rise and Fall of the Chinese Soviet Republic, 1931-1934*. Armonk: M.E. Sharpe, 822-5.
- Stephens, H. (2019). "Three Reforming Regimes? Modernity and the Fiscal State in Modern Korean History". *Seoul Journal of Korean Studies*, 32(1), 109-46. <https://doi.org/10.1353/seo.2019.0005>.
- Strand, D. (2000). "'A High Place Is No Better than a Low Place': The City in the Making of Modern China". Yeh, W. (ed.), *Becoming Chinese: Passages to Modernity and Beyond*. Berkeley: University of California Press, 98-136.
- Teng, S.; Fairbank, J.K. (1954). "Doc. 57. Ts'ai Yuan-p'ei's Views on the Aims of Education, 1912". *China's Response to the West: A Documentary Survey, 1839-1923*. Cambridge: Harvard University Press, 235-8.
- Thaxton, R. (1997). *Salt of the Earth: The Political Origins of Peasant Protest and Communist Revolution in China*. Berkeley: University of California Press.
- Tsin, M.T. (1999). *Nation, Governance, and Modernity in China: Canton, 1900-1927*. Stanford: Stanford University Press.
- VanderVen, E.R. (2012). *A School in Every Village: Educational Reform in a North-east China County, 1904-31*. Vancouver: University of British Columbia Press.
- Wakeman, F. (1993). "The Civil Society and Public Sphere Debate: Western Reflections on Chinese Political Culture", in Huang, P.C.C. (ed.), "Public Sphere/Civil Society in China: Paradigmatic Issues in Chinese Studies, III", monogr. no., *Modern China*, 19(2), 108-38. <https://doi.org/10.1177/009770049301900202>.
- Wakeman, F. (1997). *Strangers at the Gate: Social Disorder in South China, 1839-1861*. Berkeley: University of California Press.
- Wakeman, F.; Wang, X. (eds) (1997). *China's Quest for Modernization: A Historical Perspective*. Berkeley: University of California Press.
- Wang, X. (1997). "Approaches to the Studies of Modern Chinese History: External Versus Internal Causations". Wakeman, F.; Wang, X. (eds), *China's Quest for Modernization: A Historical Perspective*. Berkeley: University of California Press, 1-21.
- Yeh, W. (1997). "Shanghai Modernity: Commerce and Culture in a Republican City". *The China Quarterly*, 150, 375-94. <https://doi.org/10.1017/s0305741000052528>.



- Yeh, W. (2000). "Introduction: Interpreting Chinese Modernity, 1900-1950". Yeh, W. (ed.), *Becoming Chinese: Passages to Modernity and Beyond*. Berkeley: University of California Press, 1-16.
- Zarrow, P.G. (2005) *China in War and Revolution, 1895-1949*. London: Routledge.
- Zarrow, P.G. (2012). *After Empire: The Conceptual Transformation of the Chinese State, 1885-1924*. Stanford: Stanford University Press.
- Zhongguo renmin zhengzhi xieshang huiyi Jiangsu weiyuanhui banggongting 中国人民政治协商会议江苏委员会办公厅 (2001). *Sun Zhongshan yu Nanjing linshi zhengfu 孙中山与南京临时政府 (Sun Zhongshan and the Nanjing Provisional Government)*. Nanjing: Nanjing chubanshe.



## The Historian's Gaze

Essays on Modern and Contemporary China  
in Honour of Guido Samarani

edited by Laura De Giorgi and Sofia Graziani

# Foreign Concessions and Western Impact in the Late Qing Period: Historiographical Approaches and Political Interpretations

Marina Miranda

Sapienza Università di Roma, Italia

**Abstract** During the last few decades, the historians of the PRC have adopted different interpretative frameworks in analysing the Chinese encounter/clash with the West: from the revolutionary paradigm to the modernisation theory, from the 'impact-response' model to the 'China-centred approach'. This essay discusses how Chinese scholars have applied such frameworks in assessing the role of foreign concessions established in the treaty ports during the late Qing period: considered as a sign of the imperialist presence by the early generation of Marxist historians, international settlements have been later re-evaluated in a more positive light, in the context of a lively historiographical debate regarding their unique role in the modernisation of the country. However, the liveliness of the Chinese academic discussion has recently been suppressed due to the campaign against 'historical nihilism' launched by President Xi Jinping, which silenced any representation of modern Chinese history that does not adhere to the Party line.

**Keywords** *Zujie* 租界 (foreign concessions). *Lishi xuwuzhuyi* 历史虚无主义 (historical nihilism). Western impact. Late Qing period. Chinese historiography.

**Summary** 1 The Paradigm of the Modernisation Theory. – 2 Reassessing the Role of Foreign Concessions. – 3 The Dangers of 'Historical Nihilism'.

## 1 The Paradigm of the Modernisation Theory

In the last decades of the Qing dynasty (1644-1911), China experienced a manifold moment of crisis, going through a profound evolution of its political, institutional, and social systems. In interpreting



Edizioni  
Ca' Foscari

### Sinica venetiana 10

e-ISSN 2610-9042 | ISSN 2610-9654

ISBN [ebook] 978-88-6969-723-4 | ISBN [print] 978-88-6969-724-1

Peer review | Open access

Submitted 2022-07-26 | Accepted 2022-09-17 | Published 2023-10-11

© 2023 Miranda | © 4.0

DOI 10.30687/978-88-6969-723-4/002

such changes, both Western and Chinese scholars have adopted alternative theoretical paradigms, judging in different ways the role played by the Chinese encounter/clash with the West.

Before examining these interpretations, it is worth taking a careful look at how Chinese Marxist historiography has conceived foreign presence in nineteenth-century China: for the most part, it has been denounced as an imperialist aggression perpetrated by Western powers to encroach upon China's sovereignty. The reaction of the Chinese against this imperialist act has been highlighted by many authors, such as Fan Wenlan, who considered the people's resistance to foreign invaders as the "main thread" in modern Chinese history. Focussing on the aggressive nature of Western expansionism, he stressed how the grief and misery of the Chinese people caused by imperialist powers led to rebellions and revolutions (Fan 1949). This approach has emphasised the role of uprisings and insurgencies, giving rise to an interpretative paradigm shared by the early generation of PRC historians, such as Guo Moruo, Jian Bozan, and Li Dingsheng: in their view, the struggle against imperialism was the 'main theme' (*zhuti* 主题) of modern Chinese history, whose ontological basis was provided by the revolutionary trope.

Moving beyond the celebratory nature of Marxist scholarship, it is interesting to consider other historiographical approaches, widely endorsed at the end of the 1990s: largely influenced by Western theories of modernisation - which have had a wide impact on Chinese academic circles since the mid/late 1980s -, these new perspectives abandoned the revolutionary archetype, calling for a historical re-examination of the late Qing period.

The forerunner and main proponent of this new trend was Luo Rongqu, professor of American History at Beijing University; in the early 1980s, he gave a series of lectures at Princeton University, where he met and began an intense intellectual exchange with Cyril E. Black, author of the famous book *The Dynamics of Modernization* (1966). Fearful of being accused of introducing "Western bourgeois theories" in China, Luo did not officially begin his research on Chinese modernisation until 1986, when the Anti-Spiritual Pollution Campaign was finally over (Wang 1986). By the end of his life, Luo was considered the pioneering scholar of the modernisation paradigm, having written many volumes on this subject (Luo 1992; 1993).

Moreover, as early as 1985, Black's book had already been presented in the journal *Dushu* by Ding Xueliang, a professor at Fudan University, known for having introduced to China the theories of Durkheim, Weber, Talcott Parsons, and Huntington (Ding 1985a; 1985b). The issue of development and underdevelopment in non-Western societies was also addressed by other scholars, such as Sun Liping, Yan Lixian, and Li Huaiyin, who critically engaged with the foreign theories of modernity.

But it was only in the 1990s that the modernisation approach to the study of the late Qing period was widely accepted and recognised by the Chinese academy; in 1996, its definitive consecration would be marked by the endorsement of the President of the Chinese Academy of Social Sciences (CASS), Hu Sheng. In the preface to the second edition of the book *From the Opium War to the May Fourth Movement*, Hu argued how desirable it was and how decisive it would have been to use “modernisation” as the main narrative thread of modern history (Hu 1996): in this perspective, the focus of historical writings should have not been the nature of productive and class relations, but the transition from traditional to modern institutions, and the role of values and cultural patterns of modernity.

The historian Feng Lin further contributed to this re-interpretation, significantly in his two volumes *Rethinking a Century of the History of China*, whose synopsis reads: “The one-hundred years of modern Chinese history were not merely a history of revolution; they were, in fact, a history of modernization” (Feng 1998).

Notably, however, the wide application of this interpretative framework does not imply an uncritical acceptance of Western thoughts: indeed, the Chinese intellectuals highlighted how the context in which Western theories of modernisation emerged - namely the 1950s and 1960s, during the Cold War - carries a whole series of political and cultural implications. According to Luo Rongqu, the idea of modernity was itself a Eurocentric concept, since it assumes that only Western societies could embody the ideal prototype of modernisation. Therefore, being the product of a positive view of social evolution, the modernisation theory can be considered the ideology of the US imperialism and its hegemony in the postwar years (Luo 1992; 1993). Such criticisms have also been voiced by other scholars, such as Wang Xudong and Li Junxiang, who refused to equate modernisation with Westernisation, arguing that modernity is not the result of a linear diffusion process, that moves from the West to the East (Wang, Li 2003).

## 2 Reassessing the Role of Foreign Concessions

According to the modernisation paradigm, the root causes of China's backwardness are not to be sought outside the country, but inside it: hence, they should not be misidentified with the imperialist presence on Chinese territory in the nineteenth and twentieth centuries. Such an interpretation is ground-breaking, since, in terms of historiographical research, it opens up the possibility of viewing foreign influence as playing a positive and active role in the transformation of Qing society.

Seen from this perspective, one of the most controversial issues is related to the interpretation of the main symbol of Western oppression: foreign concessions (*zujie* 租界), established since the second half of the nineteenth century. Concessions were areas within the treaty ports, perpetually leased by the Chinese government to a foreign nation at the cost of a modest rent; foreign consuls, for their part, had the right to lease portions of this land to their fellow countryman. Indeed, since the Chinese government retained its sovereignty over the leased territory, foreigners could not directly purchase the land, but only rent it 'in perpetuity'. The concessions were also protected by extraterritoriality from the reach of the Chinese law: on the basis of this principle, foreign nations exercised their authority over their fellow citizens according to the laws of their own country.

Concessions were located both along the Chinese East Coast and inland, especially along the main waterways: Shanghai, Tianjin, Hankou, and Xiamen were among the major cities in which they were established. The Shanghai concession was the biggest one: it was created in 1863, when the British and the Americans merged their areas, giving birth to the Shanghai International Settlement (*Shanghai Gonggong Zujie* 上海公共租界). Starting from 1849, even the French set up their concession in the city.

Drawing on the modernisation paradigm, many authors, starting from the late 1990s and the early 2000s, have reassessed the role of concessions, reconsidering them no longer as 'enclaves of imperialism', but as catalyst centres of modern innovations and as key attractions for foreign commerce, investment, banking, and manufacturing. Among these authors were Zhou Jiming from People's University, Wu Shiyong from Shandong University, Xiong Yuezhi from Shanghai Academy of Social Sciences, Wang Limin from the East China University of Political Science and Law in Shanghai, Zhang Haoran from Henan Normal University, Tu Wenxue from Jiangnan University in Wuhan, Chen Mingyuan from the Chinese Academy of Social Sciences in Beijing, Yang Bingde and Chi Congwen, both from Zhejiang University.

It is worth noting that, despite their innovative approach, in the opening section of their essays, many scholars seem to adhere to the old-fashioned assumption that concessions are the product of Western

invasion: indeed, they present foreign settlements as an institutional foundation of modern capitalism, a microcosm of imperialist domination. From this standpoint, concessions are still portrayed as “the land of sin, the source of aggression, and the hell on earth” (Zhang, Niu 2004, 255), and foreign powers are depicted as carrying out reckless political, economic and cultural aggression against China, causing tremendous suffering to its people (Zhang 2008).

It seems that the purpose of these statements is to show formal respect to the ideological assumptions of the previous historiography, maintaining a dialectical approach to the subject. Indeed, these negative judgments, once given, are gradually abandoned, shifting towards a more positive appraisal of foreign concessions: instead of their nefarious impact on Chinese society, their constructive role is cautiously recognised, re-evaluating them as models of modern urban civilisation and management systems from the West (Chen 2013).

Among others, Chen Mingyuan justifies this revaluation in Marxist terms, identifying the ideological underpinning of his analysis in Marx’s concept of ‘constructive mission’ (*jianshexing shiming* 建设性使命; Chen 2013). As is well known, in *The Future Results of British Rule in India* the German philosopher had predicted that Britain and other Western power invaders would accomplish a dual mission: one was destructive, in the sense of eliminating the old Asian-style society; the other was a constructive mission, to lay the material foundation for Western-style society in Asia (Marx 1853). Drawing on Marx, Chen argues that in Shanghai, Tianjin, Wuhan, and other treaty ports, this “constructive mission” partially got rid of the corrupt imperial autocratic dictatorship and feudal bureaucracy, and initially achieved a civilised municipal version of capitalism. Therefore, he re-evaluates concessions as “constructive forces” in terms of laying the foundation for the material civilisation of modern society. From this perspective, foreign concessions are thus viewed as the initial engine of China’s modernisation process, as an opportunity to hybridise Chinese and Western cultures; they placed the modern European urban model alongside the traditional prototype of a Chinese city, challenging it in a constructive way.

Most of these studies focussed on Shanghai, defining the International Settlement as “a country within a country” (*guo zhong zhi guo* 国中之国): even though its territory formally belonged to China, it is considered a self-contained “small country” (Zhou 1997). Being China’s most modern and Westernised city, Shanghai was indeed the place where the earliest steps towards modernisation were made. In this respect, we need to remember that, as China’s greatest port city and largest multifunctional economic centre since the 1850s, Shanghai has been the major economic and cultural hub of the entire nation. Its rapid rise from the status of a small county town to that of “the largest metropolis in the Far East” and of the “Paris of the

East” (Zhang 2008) was due to the convergence of several factors: one was geographical, related to its position on the Yangzi estuary, which provided port facilities, a safe harbour and ready communication by waterways along the Yangzi as far as Sichuan province.

Another factor was economic, related to the food surplus produced in the fertile rice-growing region of the Yangzi delta and to the fact that Chinese brokers attracted capitals of landlord-gentry from the rich hinterland. Furthermore, the role of foreign government should not be overlooked, which guaranteed security and prosperity: Western merchants easily made money and enabled their Chinese assistants and counterparts to do the same.

From a management point of view, foreign powers established independent administrative, policing, and judicial institutions in the concession, with a certain degree of self-government; they stationed regular armed forces, used waterways, walls, iron fences, soldiers, and patrol guards with guns to separate the concession from the urban area, preventing the Chinese from entering and leaving at will (Zhou 1997).

In addition, there were many features of urban infrastructure and facilities in the concession that were rarely found in the traditional Chinese part of the city: modern paved streets, lighting, sewers, running water and public transport services. Foreigners enjoyed a high standard of living, based on a meat-centred diet, modern houses, stylish clothes, and leather footwear (Chen 2013). In this respect, Zhou Jiming, citing some articles published in the *Shenbao* 申报 – the most important newspaper in Shanghai at that time –,<sup>1</sup> stresses how Guo Songtao and Kang Youwei, who visited the city respectively in 1856 and 1879, were impressed by the “wonders” of modernity, especially the electric lighting, the maintenance of the streets, always kept clean and tidy (Zhou 1997). Metaphorically, modern districts were regarded as symbols of the supremacy of Western civilisation, while the traditional Chinese areas were seen as a sign of weakness. The state of the roads reflected this contrast – the old roads in the Chinese quarters were relatively narrow, uneven and dirty. They were built with mud or gravel and were dusty or muddy depending on the season.

Equally important, within the concession, were the rules for urban decorum: hanging laundry or placing household items on the facades of houses, for example, was strictly forbidden. According to the *Shenbao*, in the early 1870s fines and punishments were imposed for not respecting such rules of decorum, especially on

---

**1** Considered the most significant Chinese-language newspaper of the time, the *Shenbao* was founded by a British businessman, Ernest Major (1841-1908), and started publication in the Shanghai International Settlement in 1872 (cf. Tsai 2009).



Chinese residents (Zhang 2008). The flourishing of a local press brought a further sense of modernity.

With regard to administration, the concession implemented the separation of powers: the legislative, the judicial, and the administrative were relatively independent and counterbalanced each other. Authority was exercised by the Council of Taxpayers, made up of all foreign residents subjected to the payment of taxes. However, between the end of the nineteenth and the beginning of the twentieth century, they were only a small minority (between 5 and 10%) of the entire Chinese population (Zhou 1997). Chinese residents paid their taxes, but they lacked political representation, as would have been the case under the Chinese system.

Another noteworthy aspect was the observance of the principle of inviolability of private property and the protection of private entrepreneurship. In that way, the concessions also attracted domestic Chinese capital, thus creating the most developed area of capitalism in China (Zhou 1997).

Not to be overlooked is also the question of consular jurisdiction, which favored the introduction of Western criminal laws, in place of Chinese criminal law (Gong 2012). According to the unequal treaties, if there was a dispute between a Chinese and a foreign citizen, the peaceful mediators had to be identified by officials of the two countries. Cases involving Western subjects, regardless of person or property, were investigated and handled by foreign officials. Not being directly controlled by the Qing government and based on the principle of extraterritoriality, the concessions offered political asylum to personalities who wanted to escape the persecution of the Manchu court, for example Zhang Binglin, Yu Youren, Liu Shiwei. Besides refugees from impoverished or disaster-stricken areas who were looking for work, Shanghai sheltered about 1.5 million Chinese refugees after the Taiping rebellion in 1850, and many remained there even after the suppression of the uprising (Zhou 1997).

Another important aspect to consider is that, even though most of the aforementioned studies methodologically draw on the modernisation theory, they can also be connected, to some extent, to the 'impact-response theory' (*chongji-huiying lun* 冲击 - 回应论), proposed in the 1950s and 1960s by John K. Fairbank and the American scholars of the so-called 'Harvard School'. This theory has been questioned from a different perspective, adopted by several Chinese scholars since the 1990s: the so-called 'China-centred approach' (*Zhongguo zhongxin guan* 中国中心观) developed by Paul A. Cohen (1984).<sup>2</sup> According

---

<sup>2</sup> The first translation of Cohen's (Ke Wen in Chinese) book dates back to 1989 (Ke 1989). It was translated by Lin Tongqi, a Chinese historian who moved to the United States in 1984 and worked at Harvard University until his death in 2015.

to his vision, the ‘impact-response theory’ would have overestimated China’s encounter/clash with foreigners, conveying a marked dichotomy between a backward East and a dynamic West. The analysis of Harvard scholars indeed reveals how they are not immune from cultural biases and how they should be on alert for ethnocentric distortion. By contrast, Cohen suggests that the notion of ‘West’ is a mutable and relative concept, historically and geographically situated. Consequently, one could not look at the West as a whole, as a single entity that has a sole and unique impact on non-Western societies.

Though widely accepted by the Chinese academy (Wang, Lu 2007; Xiang 2013; Zhao, Zeng 2006), Cohen’s theory has also been questioned by some scholars who have highlighted its limits and shortcomings (Li 2010; Pan 2009; Xia 2006; Yi 2008; Zhu 2011). The ‘China-centred approach’, for instance, has been condemned for the fact that it dates the beginning of modern Chinese history back to the eighteenth or even the sixteenth century, asserting that China’s domestic political and social situation at that time would have largely defined the structural conditions of the country in the nineteenth and twentieth centuries. Invoking the concept of ‘transcendental historical continuity’, Cohen rewrites the historical modernisation process, blurring the boundary between ‘tradition’ and ‘modernity’. In this way, the chasm that separates Chinese tradition from modernity is bridged and China is presented as stepping through an ‘innate path of modernisation’ which began in the sixteenth century; consequently, deliberately and unintentionally, the role of foreign powers would be underplayed and China’s self-determining continuity would be highlighted. It is precisely this weakening of the influence of foreign imperialism that is unacceptable to Chinese scholars, as much as the downsizing of the scope of the modernisation process.

### 3 The Dangers of ‘Historical Nihilism’

The different approaches and debates examined so far are a sign of the intellectual vitality that animated the Chinese academy during recent decades. However, since President Xi Jinping came to power, such liveliness has been extinguished, mostly as a result of tightening ideological control over Chinese universities. Xi’s campaign against historical nihilism (*lishi xuwuzhuyi* 历史虚无主义) has certainly been a step in this direction.

‘Historical nihilism’ is a term widely used to label any account that challenges CCP’s orthodox narratives or that brings into question the official interpretations of the country’s history. This epithet was first used by General Secretary Jiang Zemin in 1989, when he condemned what he considered harmful tendencies then prevailing within the Party (Wang 2018). Many years later, President Xi Jinping has returned

to this concept with greater emphasis, defining it as a major misrepresentation of the history of the Communist Party and of the People's Republic, and one of several ideological vices that had 'seriously eroded' the CCP. According to Xi, historical nihilism would completely deny Marxism, the leadership of the Party, and the Chinese socialist system, undermining the foundation of CCP ideology (Xi 2016).

Historical nihilism has also been recorded among seven false ideological trends, the so-called 'Seven Unmentionables' (*qige bu yao jiang* 七个不要讲, or *qi bu jiang* 七不讲), listed within an internal (*neibu* 内部) CCP document, the "Communiqué on the Current State of the Ideological Sphere" (*ChinaFile* 2013). The document called on all media and government educational bodies to consider seven serious problems that deserved attention and that reflected the harshness and complexity of the struggle in the ideological sphere. The current Party leadership has indeed outlined 'seven speak-nots', subjects that are off-limits for academic discussion: universal values, civil society, civil rights, judicial independence, press freedom, the privileged capitalist class, and the Party's historical mistakes. And it is precisely to the latter that historical nihilism can be ascribed. In rejecting the official version that the CCP provides of its own history, historical nihilism would try to question the historical mission of the Party, contesting its legitimacy. Furthermore, close adherence to Western thought and ideas (especially political ones) could undermine the stability of the Communist regime.

In addition to the press and media, the 2013 provisions also applied to the academy: as early as 2014, a survey conducted by the Party press in more than 20 faculties of Social Sciences and Humanities in Beijing, Shanghai, Guangzhou, Wuhan, and Shenyang, denounced disrespectful lecturers and professors for presenting a distorted image of Chinese history and culture, throwing mud at the nation and glorifying the West (*Liaoning Ribao* 2014).

Furthermore, in 2019, an editorial of the *People's Daily* appealed to Chinese experts to free their research on the Qing period from the harmful influence of foreign historical nihilism (Zhou 2019). The appeal was welcomed by many Chinese scholars and academics: according to Li Shizhen, a professor at Inner Mongolia Agricultural University, historical nihilism manifests itself in resenting the Western invasion as a means to promote the modernisation of China, and in disguising the real aims of imperialism as a stimulus to the progress of Chinese civilisation (Li 2020). The potential intellectual danger of the modernisation theory is also denounced by Wang Xiaowen, from Beijing Language and Culture University, who stresses the necessity to strictly adhere to the analytical framework of historical and dialectical materialism (Wang 2017).

Zhao Xue and Han Sheng, professors at Shandong University and the Hebei Institute of Finance respectively, argue that the paradigm

of modernity is the result of the colonisation produced by the cultural imperialism of the West, whose hegemonic discourse is applied to the history of non-European contexts (Zhao, Han 2020).

The tendency towards historical nihilism has also been identified in some analyses related to foreign concessions. Particularly vocal in criticising this trend is Shen Bingqing, a professor at Fudan University: in his study on the Shanghai concession, the scholar contends that the International Settlement should not be viewed as a closed space with an efficient governance system, as often defined by those analysts that emphasise its management efficacy (Shen 2018). Conversely, Shen judges the governance of the Shanghai International Settlement to be ineffective, also questioning its legal legitimacy, as it is derived from unequal treaties. For Shen, inefficiencies could be found at the administrative, financial, and jurisdictional levels, for example in the conflicts between European consuls and foreign taxpayers. But they are most evident in relation to the Chinese residents, who suffered racial discrimination. Furthermore, the European administrative model is considered to be responsible for hindering the development of modern associations and local enterprises, hampering the replacement of traditional organisations and jobs.

In conclusion, due to this kind of analysis, which presents a 'correct' and unilateral vision of history, the lively debates of the past decades, mostly based on scholarly conversations between Chinese and Western academic communities, have been completely silenced. This trend is extremely worrying, since it marks a turning point for independent research, which has always been one of the main targets of Party censorship, but is now encountering unprecedented difficulties.

## Bibliography

- Bickers, R.A.; Wasserstrom, J.N. (1995). "Shanghai's 'Dogs and Chinese Not Admitted' Sign: Legend, History and Contemporary Symbol". *The China Quarterly*, 142, 444-66.
- Black, C.E. (1966). *The Dynamics of Modernization: A Study in Comparative History*. New York: Harper & Row.
- Chen Mingyuan 陈明远 (2013). "Zhongguo zujie shi de zai renshi - Zujie biao zhizhe Zhongguo xiandaihua jincheng de kaiduan" 中国租界史的再认识 – 租界标志着中国现代化进程的开端 (Reinterpreting the History of Chinese Concessions: The Concessions Mark the Beginning of the Modernisation Process in China). *Shehui Kexue Luntan* 社会科学论坛, 7, 4-20.
- ChinaFile (2013). "Document 9: A ChinaFile Translation: How Much Is a Hardline Party Directive Shaping China's Current Political Climate?". *ChinaFile*, 8 November. <https://www.chinafile.com/document-9-chinafile-translation>.

- Cohen, P.A. (1984). *Discovering History in China: American Historical Writing on the Recent Chinese Past*. New York: Columbia University Press.
- Ding Xueliang 丁學良 (1985a). “Xiandaihua he butong shehui de jiegou” 现代化和不同社会的结构 (Modernisation and Different Social Structures). *Dushu* 读书, 8, 105-18.
- Ding Xueliang 丁學良 (1985b). “Yiben xiandaihua bijiao yanjiu de daolun” 本现代化比较研究的导论 (An Introduction to a Comparative Study of Modernisation). *Dushu* 读书, 3, 112-16.
- Dirlik, A. (1996). “Reversals, Ironies, Hegemonies: Notes on the Contemporary Historiography of Modern China”. *Modern China*, 22(3), 243-84.
- Dirlik, A. (2002). “Modernity as History: Post-Revolutionary China, Globalization and the Question of Modernity”. *Social History*, 27(1), 16-39.
- Dirlik, A. (2007). “The Historiography of Colonial Modernity: Chinese History between Eurocentric Hegemony and Nationalism”. *Journal of Modern Chinese History*, 1(1), 97-115.
- Esherick, J. (1972). “Harvard on China: The Apologetics of Imperialism”. *Bulletin of Concerned Asian Scholars*, 4(4), 9-16.
- Fairbank, J.K. (1959). “A Note of Ambiguity: Asian Studies in America”. *The Journal of Asian Studies*, 19(1), 3-9.
- Fan Wenlan 范文澜 (1949). *Zhongguo Jindaishi* 中国近代史 (Modern History of China). Shanghai: Shenghuo Dushu Xinshi.
- Feng Lin 枫林 (ed.) (1998). *Chongxin Renshi Bainian Zhongguo: Jindaishi Reidian Wenti Yanjiu yu Zhengming* 重新认识百年中国: 近代史热点问题与争鸣 (Rethinking China in a Century: Hot Issues and Controversies in Modern History). 2 vols. Beijing: Gaige chubanshe.
- Gong Pixiang 公丕祥 (2012). “Sifa zhuquan yu lingshi caipanquan - Wan Qing sifa gaige dongyin fenxi” 司法主权与领事裁判权 - 晚清司法改革动因分析 (Judicial Sovereignty and Consular Jurisdiction: An Analysis of the Impulse of Judicial Reform in the Late Qing Dynasty). *Falü Kexue* 法律科学, 3, 3-11.
- Hu Sheng 胡绳 (1996). “Cong Yopian zhanzheng dao Wusi yundong zaiban xuyan” 从鸦片战争到五四运动再版序言 (Foreword to the Second Edition of ‘From the Opium War to the May Fourth Movement’). *Jindaishi Yanjiu* 近代史研究, 2, 11-28.
- Huang, P.C.C. (1991). “The Paradigmatic Crisis in Chinese Studies: Paradoxes in Social and Economic History”. *Modern China*, 17(3), 299-341.
- Huang, P.C.C. (1996). “Theory and the Study of Modern Chinese History: Four Traps and a Question”. *Modern China*, 24(2), 183-208.
- Huang, P.C.C. (2016). “Our Sense of Problem: Rethinking China Studies in the United States”. *Modern China*, 42(2), 115-61.
- Jia, R. (2014). “The Legacies of Forced Freedom: China’s Treaty Ports”. *Review of Economics and Statistics*, 96(4), 596-608.
- Ke Wen 柯文 (Cohen, P.A.) (1989). *Zai Zhongguo Faxian Lishi* (Zhongguo Zhongxin Guan zai Meiguo de Xingqi) 在中国发现历史 (中国中心观在美国的兴起) (Discovering History in China – The Rise of the China-Centred Approach in America). Beijing: Zhonghua Shuju.
- Li, H. (2010a). “Between Tradition and Revolution: Fan Wenlan and the Origins of the Marxist Historiography of Modern China”. *Modern China*, 36(3), 269-301.
- Li, H. (2010b). “From Revolution to Modernization: The Paradigmatic Transition in Chinese Historiography in the Reform Era”. *History and Theory*, 49(3), 336-60.

- Li, H. (2012). *Reinventing Modern China: Imagination and Authenticity in Chinese Historical Writing*. Honolulu: University of Hawaii Press.
- Li Shizhen 李士珍 (2020). “Jingti jindai waiguo qin hua shi yanjiu zhong de lishi xuwuzhuyi” 警惕近代外国侵华史研究中的历史虚无主义 (Be Aware of Historical Nihilism in the Study of the History of Foreign Aggression against China in Modern Times). *Shijie Shehuizhuyi Yanjiu* 世界社会主义研究, 7, 46-56.
- Li Xuezhi 李学智 (2010). “Chongji - Huiying moshi yu Zhongguo zhongxin guan - Guanyu ‘Zai Zhongguo faxian lishi’ de ruogan wenti” 冲击 - 回应模式与中国中心观 - 关于‘在中国发现历史’的若干问题 (The ‘Impact-Response’ Model and the ‘China-Centred Approach’: Several Questions about ‘Discovering History in China’). *Shixue Yuekan* 史学月刊, 7, 92-101.
- Liaoning Ribao 辽宁日报 (2014). “Liaoning Ribao: ‘Laoshi, qing buyao zheyang jiang Zhongguo’” 辽宁日报: ‘老师请不要这样讲中国’ (*Liaoning Daily: ‘Teachers, Please Don’t Talk about China like That’*). *Xinhua wang* 新华网 (*Xinhua net*). [http://www.xinhuanet.com/politics/2015-08/28/c\\_128177114.htm](http://www.xinhuanet.com/politics/2015-08/28/c_128177114.htm).
- Lin, X.D. (2012). “John K. Fairbank’s Construction of China, 1930s-1950s: Culture, History, and Imperialism”. *The Journal of American-East Asian Relations*, 19(3-4), 211-34.
- Luo Rongqu 罗荣渠 (1986). “Xiandaihua lilun yu lishi yanjiu” 现代化理论与历史研究 (Modernisation Theory and Historical Studies). *Lishi Yanjiu* 历史研究, 3, 19-32.
- Luo Rongqu 罗荣渠 (1992). *Xiandaihua Xinlun: Shijie he Zhongguo de Xiandaihua Jincheng* 现代化新论: 世界和中国的现代化进程 (A New Theory of Modernisation: The Modernisation Process in China and the World). Beijing: Beijing Daxue chubanshe.
- Luo Rongqu 罗荣渠 (ed.) (1993). *Geguo Xiandaihua Bijiao Yanjiu* 各国现代化比较研究 (A Comparative Study of the Modernisation in Various Countries). Xi’an: Sha’anxi Renmin chubanshe.
- Marx, K. (1853). “The Future Results of British Rule in India”. *New-York Daily Tribune*, 8 August. <https://marxists.architexturez.net/archive/marx/works/1853/07/22.htm>.
- Morken, H. (1977). “Protecting American Commerce in China: Washington’s Approach to Urban Concessions, 1876-1885”. *The Historian*, 40(1), 53-69.
- Pan Nana 潘娜娜 (2009). “Ouzhou zhongxin guan yu Zhongguo zhongxin guan neihan yanbian yanjiu” 欧洲中心观与中国中心观内涵演变研究 (A Study on the Evolution of the Connotations of Eurocentrism and of the ‘China-Centred Approach’). *Henan Shehui Kexue* 河南社会科学, 17(4), 132-4.
- Shen Bingqing 沈冰清 (2018). “Zai zujiejie wenti shang ying jianjue fandui lishi xuwuzhuyi - Yi Shanghai gonggong zujiejie wei anli in 租界问题上应坚决反对历史虚无主义 - 以上海公共租界为案例 (Resolutely Oppose Historical Nihilism on the Issue of Foreign Concessions: A Case Study of the Shanghai International Settlement)”. *Xueshu Qianyan* 学术前沿, 6, 92-5.
- Tsai, W. (2009). *Reading Shenbao: Nationalism, Consumerism and Individuality in China 1919-37*. New York: Springer.
- Tu Wenxue 涂文学 (2009). “Jindai Hankou shizheng gaige dui zujiejie de xiaofa yu chaoyue” 近代汉口市政改革对租界的效法与超越 (Following the Example of the Concession and Surpassing It in Modern Municipal Reform in Hankou). *Jiangnan Daxue Xuebao* 江汉大学学报, 6(4), 82-7.

- Veesser, C. (2013). "A Forgotten Instrument of Global Capitalism? International Concessions, 1870-1930". *The International History Review*, 35(5), 1136-55.
- Wang Aiyun 王爱云 (2018). "Gaige kaifang yilai Zhongguo Gongchandang lingdao fandai lishi xuwuzhuyi de shijian yu jingyan" 改革开放以来中国共产党领导反对历史虚无主义的实践与经验 (Since the Reform and Opening-Up, the Leadership of the Communist Party of China Has Opposed the Practice and Experience of Historical Nihilism). *Makesizhuyi Yanjiu* 马克思主义研究, 5, 130-40.
- Wang Haiyan 王海燕; Lu Wen 陆玮 (2007). "Ke Wen 'Zhongguo zhongxin guan' jiqi yingxiang" 柯文的 '中国中心观' 及其影响 (Paul A. Cohen's 'China-Centred Approach': And Its Influence). *Zhangzhou Shifan Xueyuan Xuebao* 漳州师范大学学报, 4(66), 137-41.
- Wang Limin 王立民 (2008). "Zhongguo de zujie yu fazhi xiandaihua - Yi Shanghai, Tianjin he Hankou de zujie wei li" 中国的租界与法制现代化 - 以上海天津和汉口的租界为例 (The Chinese Concessions and the Modernisation of the Legal System: A Case Study from Shanghai, Tianjin, and Hankou). *Zhongguo Faxue* 中国法学, 3, 167-77.
- Wang, S. (1986). "The Rise and Fall of the Campaign against Spiritual Pollution in the People's Republic of China". *Asian Affairs*, 13(1), 47-62.
- Wang Xiaowen 王晓文 (2017). "Jingtai xiandaihua yanjiu zhong de lishi xuwuzhuyi" 警惕现代化研究中的历史虚无主义 (Be Aware of Historical Nihilism in Modernisation Studies). *Shandong Shehui Kexue* 山东社会科学, 3(259), 143-8.
- Wang Xudong 王旭东; Li Junxiang 黎俊祥 (2003). "Yi xiandaihua wei zhuxian luelun Zhongguo jindaishi yanjiu" 以现代化为主线略论中国近代史研究 (A Brief Discussion on the Research of Modern Chinese History with Modernisation as the Main Line). *Shixue Lilun Yanjiu* 史学理论研究, 3, 38-46.
- Wu Shiyang 吴士英 (1998). "Lun zujie dui jindai Zhongguo shehui de fuza yingxiang" 论租界对近代中国社会的复杂影响 (The Complex Influence of Foreign Concessions on Modern Chinese Society). *Wen Shi Zhi* 文史哲, 5, 95-100.
- Xi Jinping 习近平 (2016). "Lishi buke xuwu" 历史不可虚无 (History Cannot Be Annihilated). *Zhongguo Ribao* 中国日报 - Zhongwen wang 中文网 (China Daily - Chinese Language Website), 20.10. [https://china.chinadaily.com.cn/2016-10/20/content\\_27123201.htm](https://china.chinadaily.com.cn/2016-10/20/content_27123201.htm).
- Xia Mingfang 夏明方 (2006). "Shiba shiji Zhongguo de xiandaixing jiangou - 'Zhongguo zhongxin guan' zhudao xia de qingshi yanjiu fansi" 十八世纪中国的现代性建构 - '中国中心观' 主导下的清史研究反思 (The Construction of Modernity in China in the Eighteenth Century: Reflections on the Study of Qing History on the Basis of the 'China-Centred Approach'). *Shilin* 史林, 6, 116-42.
- Xiang Tianyuan 向天渊 (2013). "Xiandai wenxue yanjiu zhi 'Zhongguo zhongxin guan' de xingqi" 现代文学研究之 '中国中心观' 的兴起 (The Rise of the 'China-Centred Approach' in Modern Literary Studies). *Hunan Daxue Xuebao* 湖南大学学报, 39(1), 88-99.
- Xiao Wenming 肖文明 (2016). "Hongda xushi de tanxun yu Zhongguo zhongxin guan de zai sikao" 宏大叙事的探寻与中国中心观的再思考 (An Investigation of the Grand Narrative and a Rethinking of the 'China-Centred Approach'). *Xueshu Yanjiu* 学术研究, 5, 71-7.
- Yang Bingde 杨秉德; Chi Congwen 池从文 (2010). "Zhongguo jindai chengshi de xiandaihua jincheng yanjiu" 中国近代城市的现代化进程研究 (Research

- on the Modernisation Process of Chinese Modern Cities). *Huazhong Jianzhu* 华中建筑, 9, 5-8.
- Yi Xin 易鑫 (2008). “Meiyou ‘zhongxin’ de Zhongguo zhongxin guan” 没有‘中心’的中国中心观 (The ‘China-Centred Approach’ That Has Not a ‘Centre’). *Anhui Wenxue* 安徽文学, 12, 61-2.
- Yu, C. (2008). “The Making of a Bund in China: The British Concession in Xiamen (1852-1930)”. *Journal of Asian Architecture And Building Engineering*, 7(1), 31-8.
- Zhang Haoran 张浩然 (2008). “Zujie yu jindai Shanghai shizheng xiandaihua” 租界与近代上海市政现代化 (Concession and Modern Shanghai Municipal Modernisation). *Jiaozuo Shifan Gaodeng Zhuanke Xuexiao Xuebao* 焦作师范高等专科学校学报, 24(1), 37-40.
- Zhang, X. (2015). “In and Out of the West: On the Past, Present, and Future of Chinese Historical Theory”. *History and Theory*, 54(4), 46-63.
- Zhang Yan 张研; Niu Guanjie 牛贯杰 (2004). *Qingshi Shiwu Jiang* 清史十五讲 (Fifteen Lectures on Qing History). Beijing: Beijing Daxue chubanshe.
- Zhao Wei 赵炜; Zeng Fanyuan 曾凡远 (2006). “Zai Zhongguo zhongxin guan zhong queli chuantong zhengzhi wenming guan” 在中国中心观中确立传统政治文明观 (Establishing an Outlook of Traditional Political Civilisation in the ‘China-Centred Approach’). *Henan Gongye Daxue Xuebao* 河南工业大学学报, 2(4), 51-5.
- Zhao Xue 赵雪; Han Sheng 韩升 (2020). “Quanqiuhua shi yu nei lishi xuwuzhuyi sichao de shengcheng yu pipan - Jian lun shijie wenhua de xiandai zhixu” 全球化视阈内历史虚无主义思潮的生成与批判 - 兼论世界文化的现代秩序 (The Creation and Criticism of Historical Nihilism in the Perspective of Globalisation: Together with the Modern Order of World Culture). *Nei Menggu Shehui Kexue* 内蒙古 社会科学, 41(6), 53-9.
- Zhou Jiming 周积明 (1997). “Zujie yu Zhongguo zaoqi xiandaihua” 租界与中国早期现代化 (Concessions and China’s Early Modernisation). *Jiangnan Luntan* 江汉论坛, 6, 31-8.
- Zhou Qun 周群 (2019). “Laolao bawo Qingshi yanjiu huayuquan” 牢牢把握情史研究话语权 (Firmly Grasp the Right to Speak of Qing History). *Renmin Ribao* 人民日报.
- ZhuHu 朱浒 (2011). “‘Fanshiweiji’ tuxianderenshiwuqu - DuiKeWenshi ‘Zhongguo zhongxin guan’ de shijianxing fansi” ‘范式危机’ 凸显的认识误区 - 对柯文式‘中国中心观’的实践性反思 (Misunderstandings Highlighted in the ‘Crisis of Paradigms’: Some Practical Reflections on Paul Cohen’s ‘China-Centred Approach’). *Shehui Kexue Yanjiu* 社会科学研究, 4, 133-45.



## The Historian's Gaze

Essays on Modern and Contemporary China  
in Honour of Guido Samarani

edited by Laura De Giorgi and Sofia Graziani

# Patterns and Trends of World History/Global History in the People's Republic of China: Reflections by Prof. Ge Zhaoguang

Elisa Giunipero

Università Cattolica del Sacro Cuore, Italia

**Abstract** The essay examines selected relevant study and research in the field of World History/Global History in the People's Republic of China. One of the most authoritative Chinese voices in the current panorama of the studies, that of historian Ge Zhaoguang 葛兆光, is presented here through a series of reflections expressed in his texts, podcasts and in personal exchanges of views with the Author of the essay. What emerges is how the historiographical approach of what in Chinese is called *quanqishi* 全球史 (World History/Global History) constitutes in itself a stimulating challenge both to the narrative of the uniqueness of Chinese national history, based on its past, and to a new Nationalist rhetoric.

**Keywords** World history. Global history. Sinocentrism. Ge Zhaoguang. World view.

**Summary** 1 Defining World History/Global History in Chinese. – 2 World History/Global History Studies in the PRC. – 3 Global History and China/from China: Inserting China in Global History.

## 1 Defining World History/Global History in Chinese

In modern Chinese historiography, there has been a significant separation between a 'national history' (*benguoshi* 本国史) of China and a 'history of the world' (*shijieshi* 世界史) dealing with countries outside China (also called *waiquoshi* 外国史, 'foreign history'), particularly Western countries (also called *xiyangshi* 西洋史, 'Western history'). In the early decades of the twentieth century, the interest of



### Sinica venetiana 10

e-ISSN 2610-9042 | ISSN 2610-9654

ISBN [ebook] 978-88-6969-723-4 | ISBN [print] 978-88-6969-724-1

Peer review | Open access

Submitted 2022-07-26 | Accepted 2022-12-07 | Published 2023-10-11

© 2023 Giunipero | © 4.0

DOI 10.30687/978-88-6969-723-4/003

Chinese scholars in the 'history of the world' was mainly motivated by the desire to understand the decline of China's role in the international scenario. After 1949 - when the People's Republic of China (PRC) borrowed Marxist historical materialism and its world history theory from the Soviet Union -, the use of the term *shijieshi* spread widely in Chinese academic circles. Although there has been some significant resistance by historians to ideological control, the task assigned by the new regime to historians was to study the development of the world socialist revolution within which the establishment of the 'new democracy' promoted by the Chinese Communist Party (CCP) began to take place (Fan 2021). In 1964, the Chinese Academy of Social Sciences founded its own Institute of World History (*Zhongguo shehui kexueyuan shijie lishi yanjiusuo* 中国社会科学院世界历史研究所). The institute undertook a separate study of the different world areas remaining unrelated to the historiographical approach of World History/Global History.

It is impossible not to overlook the difficulty and ambiguity of the terminology. Historiographical perspective on World History/Global History uses different terminological formulations in different languages, and this can often lead to misunderstanding. In material published in China and in related discussions, similar terms are often applied to different approaches. The term 'history of the world' (*shijieshi* 世界史) often refers to specific historical studies of countries other than China, while 'global history' (*quanqiushi* 全球史) refers to the historiographical approaches of World History/Global History and mainly deals with history of the connections between different human communities.

In fact, the approaches of World History/Global History concern "the story of connections within the global human community", to use Manning's definition (2003, 3), and emerge from an attempt by part of the Anglophone scholarship to overcome the concept of 'universal history', to break free from a teleological and Eurocentric vision and to abandon the centrality of nation-states. In the early 1960s, William McNeill put the accent on relationships, interactions, and networks that transcend spatial divides. Here we do not wish to delve into the complexity of the debate around the definition of 'World History/Global History' and the use of the term. However, a fundamental point to be made is that the interpretative paradigm of World History/Global History evidences an endeavour to abandon what is known as 'conceptual Eurocentrism' and not to ignore the particularities and specificities of the histories of Others (Conrad 2016, 164-75). While using analytical concepts across time and space, it is important to be aware that concepts and terms always have their own historicity and are not neutral. In fact, they bear traces of the context and conditions from which they emerged. Although Chinese historians try to break

away from the influence of Eurocentrism in the discussion of World History/Global History, they often take as their basis European and American historical categories, which are not always suitable to explain the Chinese reality. Thus World History/Global History often receives criticism in China, with accusations of being Eurocentric even in the critique of Eurocentrism. Actually, one of the emerging methodological sensitivities of World History/Global History is the attention to what is defined in technical terms by the term 'positional-ity', i.e. the awareness that the place where a global historian writes is decisive for his point of view and shapes the way in which she/he reads and interprets history (Conrad 2016, 162-84; Beckert, Sachsenmaier 2018, 1-15).

In the panorama of World History/Global History studies in the PRC, a particularly interesting contribution comes from Prof. Ge Zhaoguang 葛兆光, a historian who was Director of the National Institute for Advanced Humanistic Studies at Fudan University (Shanghai) from 2007 to 2013. Born in 1950 in Shanghai, Prof. Ge graduated from Peking University in 1984. After teaching at Yangzhou University, he was a faculty member of Tsinghua University from 1992 to 2006 and was appointed to the post of Professor in the Department of History. Since the late 1990s, he has acquired extensive international experience as visiting scholar in Hong Kong and Taiwan, as well as in Japan, Belgium and the United States.

From 2019 to 2021, Prof. Ge Zhaoguang promoted and coordinated the production of the podcast *Global history from the Perspective of China* with hundreds of episodes in Chinese, divided into six seasons.<sup>1</sup> Each season corresponds to a key theme: the origin of humanity, wars and migrations, the circulation of goods, religions and faiths, diseases and climate, and the great geographical discoveries.<sup>2</sup> With the collaboration of various experts, this audio programme is making a significant contribution to the dissemination of themes and approaches of World History/Global History in the PRC. As he himself recently explained to the Author of this essay in a private conversation, Prof. Ge Zhaoguang gathered together over 20 young scholars to produce a set of more than 200 episodes using the Vistopia audio platform. The aim has been to guide society towards a sense of global citizenship that transcends the nation, one which leads to a feeling of

**1** The podcast *Cong Zhongguo chufa de quanqiu shi* 从中国出发的全球史 (Global History from the Perspective of China) is accessible by downloading the app: <https://bit.ly/3B1TKeJ> (fee required).

**2** It should be noted that many contributions by Chinese historians in the field of World History/Global History have so far focussed more on methodological and conceptual issues, while still relatively few works are addressing specific themes of World History/Global History. This podcast, due to the variety of topics covered, is therefore particularly rich and innovative.

unity through equality and fraternity. The podcast concluded in 2021 and is now being compiled into a book.<sup>3</sup> Over the course of two and a half years, it is believed that nearly 100,000 listeners tuned in several million times. A survey was undertaken which shows that the audience includes not only university students, postgraduate students, and white-collar intellectuals, but also scholars in different fields, including economists, sociologists, legal scientists, not to mention famous intellectuals and opinion leaders.

As for the discussion on terminology, Prof. Ge Zhaoguang explains that academic circles in the PRC are generally clear on a few points: 'history of the world', *shijieshi* 世界史, is composed of regional or national histories and is written in the style of a 'puzzle'; it forms a historical narrative from a particular perspective (e.g. European-centred or China-centred) and it refers to an 'era' (five social formations, ancient times, medieval times, or modern times); 'global history', *quanqiushi* 全球史, on the other hand, transcends national borders, emphasises interconnection, influences and intertwining, and advocates a 'decentralised' historical narrative often embracing a long-term period.

As Ge has noted, nowadays in the PRC:

in general learning and academic settings, 'history of the world' (or 'history of all nations' or 'foreign history') and 'Chinese history' are still regarded as separated. In Chinese universities and secondary schools, 'history of the world' seems to be mainly foreign history other than China. In China, a 'world history without China' and a 'Chinese history without the world' have come into being, and we criticise this. The history of China and that of the world do not seem to communicate other than what is referred to as 'the history of Sino-foreign relations'. Moreover, the basic context and focus of analysis of the narrative of 'history of the world' have been influenced by the Western view of the evolution, development and progress of civilisation, the Marxist view of economic history, and the Soviet Union's five-social-formation theory, so that changes in the 'history of the world' seem to have fixed 'rules' or 'purposes'.<sup>4</sup>

As Conrad noted, in China "Global History is not generally regarded as a methodological alternative but as a context in which the growth of the nation can be explained and promoted" (2016, 208).

<sup>3</sup> The publication of the book collecting the podcast materials is in progress. Prof. Ge Zhaoguang, the curator, estimates that it will be published at the end of 2023.

<sup>4</sup> Conversation with the Author on 31 March 2022. The translation into English was reviewed by Ge Zhaoguang.

## 2 World History/Global History Studies in the PRC

It is perhaps no coincidence that World History/Global History entered the People's Republic of China in the 1980s, in the climate of 'Reform and Opening-up', when the expression 'universal view of history' was translated into Chinese as *quanqiu shiguan* 全球史观 (Liu 2012, 491-511; Spakowski 2009, 475-95). More precisely, this term comes from the translation of Geoffrey Barraclough's work, *Main Trends in History*, which appeared in the Chinese language in 1987 (Barraclough 1987). The following year, a volume by L.S. Stavrianos was also published in Chinese and later, especially in the 2000s, texts by several world historians were translated and published, including McNeill, Bentley and Pomeranz.

According to Ge Zhaoguang, Chinese historians have been aware since the 1990s that World History/Global History has a different research model to the 'history of the world'. In the 20 years since 2000, many foreign works on Global History have been translated and published in China: apart from those by John R. McNeill, Jared Diamond and other works that influenced the direction of Global History, there have also been publications of complete, systematic Global History works. One such example is Jerry Bentley and Herbert Ziegler's *Traditions & Encounters: A Global Perspective on the Past* (Peking University Press, 2007), which has now reached its sixth edition. In 2020 alone, two important translations were published: L.S. Stavrianos' *A Global History: From Prehistory to the 21st Century* (Peking University Press, 2020) and *The Penguin History of the World* (Oriental Publishing Center, 2020) by J.M. Roberts and O.A. Westad. "Interestingly", says Prof. Ge, "the Chinese version of *The Penguin History of the World*, which should have used the term 'World History' (*shijieshi* 世界史) was specifically changed into *Penguin Global History* (*Qíe quanqiusi* 企鹅全球史). Perhaps this shows how popular Global History is in China".<sup>5</sup>

While continuously dealing with the strong influence of ideology and the persistence of the Marxist framework, new attempts at re-reading China's past and present history are based on patterns seen in the global past. In recent years, these attempts have been confronted with a pressing demand from the Chinese government to put the work of historians at the service of the 'Belt and Road Initiative'. Perez-Garcia presents the debate on a "Global History with Chinese characteristics" (2021). In this regard, the position expressed by Zhang Xupeng 张旭鹏, in an article appeared in 2020 in the influential journal *Lishi yanjiu* 历史研究, is noteworthy. He argues that for China, with its long historiographical traditions, the nation-state is still an

<sup>5</sup> Conversation with the Author on 31 March 2022.

important framework for the development of historical narrative and that the goal of Global History is not to transcend or dissolve the nation-state, but to reshape the understanding of the nation-state in a larger space and time. "This dialectical relationship between global history and national narratives makes it possible to construct a global history with Chinese characteristics". And he goes on:

This understanding of the self and the world developed within the national narrative rather than outside it will become an important methodological premise for constructing a global history with Chinese characteristics, and it is also the contribution of Chinese historiography to global history. (Zhang 2020, 155-6)

Nonetheless, as Perez-Garcia has noted,

history in China has strong political connotations, and one of the objectives of the 'Silk Road' policy is to renew the cultural exchanges and encounters between the West and China. [...] Today in China the role of global history is to develop a new national narrative to foster the unification of the country through a shared common past of more than fifty ethnic minorities. (2021, 3-4)<sup>6</sup>

Chinese historians are faced with neo-nationalistic narratives that reinterpret past history with the political intent of creating a new national identity and a new image for China in the world. However, in the PRC there are researches into the perspective of World History/Global History, and the output of Chinese intellectuals in the dialogue with the international academic community deserves careful attention and in-depth understanding and discernment.

Studies in World History/Global History have developed in the PRC in particular since the early 2000s. As Prof. Ge Zhaoguang puts it, when the concept of World History/Global History arrived in China in the 1990s, it aroused great interest in academic circles and, to a certain extent, corrected several major problems in past "history of the world". As Ge Zhaoguang says,

The threshold for Global History is very high and puts forward higher requirements for scholars, requiring them not only to be experts in the history of a country, but also to have a broader vision and be good at unearthing historical documents, archaeological materials, and even anthropological investigations that are obscured by national histories. Moreover, Chinese historians are

<sup>6</sup> See also Global History Network in China (GHN) at the website <https://www.globalhistorynetwork.com>.

required to understand China in a peripheral or even global context, and world historians should link Global History and Chinese history together in their investigations. However, the current state of Global History research in China can be described with a Chinese saying: “The thunder is loud, but the rain is small”. That is to say that internationally there are many popular theories on Global History but there are very few Chinese attempts at writing Global History. I have always felt that Global History deals more with perspective and awareness of research methodology rather than being a grand narrative of “a vast territory and a long history”, and although China has now engaged in translating global histories of e.g. pepper, cotton, tea, and white sugar, there are very few Chinese research in these specific fields.<sup>7</sup>

Capital Normal University (*Shoudu shifan daxue* 首都师范大学) was the first university to establish a Global History research centre in the PRC: the university's Global History Center (*Quanqiushi yanjiu zhongxin* 全球史研究中心)<sup>8</sup> was set up in 2004, followed by centres set up by other academic institutions. Beijing Foreign Studies University (*Beijing waiguoyu daxue* 北京外国语大学) founded the Institute for Global History, IGH (*Quanqiushi yanjiuyuan* 全球史研究院), in 2014 and Shandong University (*Shandong daxue* 山东大学) established the Institute of Global History and Transnational History (*Quanqiushi yu kuaguoshi yanjiuyuan* 全球史与跨国史研究院) in 2016 (Wang 2018).<sup>9</sup> Over the past few years, IGH, headed by Prof. Li Xuetao 李雪涛, has been noted for its lively, rigorous approach. In fact, as a qualifying aspect of its work it has chosen to reject any perspective centred on a geographical area.<sup>10</sup> Such a feature is in line with the views of IGH's Director, who is adamant that Global History research must avoid both “Eurocentrism (*Ouzhou zhongxin lun* 欧洲中心论)” and “Sino-centrism (*Zhongguo zhongxin zhuyi* 中国中心主义)” (Li 2014). In contrast to Nationalist views most commonly seen at present among Chinese historians, IGH launched its journal *Global History and China* (*Quanqiushi yu Zhongguo* 全球史与中国) in 2017; through the study of China in Global History, this journal aims to show how today's Chinese civilisation is the result of exchanges with different cultures and

---

7 Conversation with the Author on 31 March 2022.

8 The centre's website: <https://ghc.cnu.edu.cn>; an English version is also available: <https://ghc.cnu.edu.cn/english>.

9 For more information, see <https://globalhistory.bfsu.edu.cn/index.htm#> and <https://www.media.sdu.edu.cn/info/1002/13669.htm>.

10 In the self-introduction posted on the IGH website itself, the rejection of any form of ‘centrism’ is placed in the foreground (*Fandui ge zhong xingshi de zhongxinzhuyi xueshuo* 反对各种形式的中心主义学说, Oppose all forms of centrism). See <https://globalhistory.bfsu.edu.cn/ar.htm?opType=view&cheLID=10#>.

to investigate the global significance of Chinese culture. The journal, co-edited by Prof. Li Xuetao and Prof. Wolfgang Kubin, is published in Chinese and outstanding Chinese and foreign scholars in the field of World History/Global History contribute to the publication.

The most well-known journal of World History/Global History in the PRC, however, remains the *Global History Review* (*Quanqiushi pinglun* 全球史评论), published in the Chinese language by the above-mentioned Capital Normal University research centre.<sup>11</sup> The journal is currently edited by Liu Xincheng 刘新成, who has held this role since the publication began in 2008, and by Liu Wenming 刘文明. Until 2014 it was published annually with the release of a monographic issue each year, while it has been published semi-annually since 2015. The journal aims to disseminate in the PRC the themes and theories of the international debate on World History/Global History, hosting contributions by well-known foreign world historians and reviews of the most important World History/Global History texts published in the West. Jerry Bentley, for example, contributed to the journal between 2006 and 2012 and was a visiting professor at the research centre where it is published. In the editorial of the second volume (2009) of the journal, Liu Xincheng traced the underlying vision, identifying the concept of 'interaction' (*hudong* 互动) between different civilisations as the engine of human history and the cornerstone of World History/Global History (cf. Liu 2009, 3-12). Liu agrees with the harsh criticism of Eurocentrism/Western-centrism shared by most Chinese historians but, at the same time, argues for the need to move beyond the sole dimension of national history in favour of an approach that fully embeds China into global history. Thus, he ultimately recognises that, like other civilisations, Chinese civilisation too progresses through relationships and exchanges with external worlds. At a time in history when it is not obvious to find alternative paths to nationalistic thinking and sentiment, the World History/Global History approach offers wide-ranging and forward-looking perspectives.

The issues of the *Global History Review* feature many contributions by foreign historians and many reviews of volumes written by Western scholars. Among the main themes addressed by Chinese historians in their research articles, the areas that emerge in particular are: environmental history; the history of empires (often addressed through the comparison between the Chinese empire and other empires of the past, or the exchanges between ancient China and the Graeco-Roman world); the history of the seas and oceans, with attention to the role of

<sup>11</sup> The list of volumes published until 2018 is available on the following webpage: <https://ghc.cnu.edu.cn/zxkw/index.htm>. In addition to this journal, another one appeared in 2021, entitled *Quanqiushi* 全球史 (The Chinese Journal of Global History), edited by Li Xuetao and published by Shehui Kexue Wenxian Chubanshe 社会科学文献出版社 (Social Science Literature Press).



ports and more generally to commercial and cultural exchanges; the history of Central Asia as a privileged place for the intertwining cultural and economic exchange between China and the West.

### 3 **Global History and China/from China: Inserting China in Global History**

Ge Zhaoguang entitled his podcast *Global History from the Perspective of China*, but he specifically clarifies that “from [the perspective of] China” and “China-centred” are completely different ideas. In Global History the ‘centre’ should be disintegrated and ‘connectivity’ should be emphasised. “Global History from China” does not indicate that China is competing for a share in Global History highlighting its historical status; rather, it means that the world is looked at from the perspective of China. In short: “If China is the centre, it goes against the ideal of Global History”.<sup>12</sup>

Prof. Ge gives three arguments to explain the underlying idea behind the choice of title. Firstly, he reminds us that no historian can be omniscient and omnipotent, and look at Global History 60 degrees without blind spots.<sup>13</sup> He recalls and underlines the importance of the above-mentioned ‘positionality’ of global historians. The second argumentation regards the awareness that Chinese historians are paying attention to Global History from the position and perspective of China. From this point of view, this ‘perspective’ and those coming from Japan, Europe, the United States and Australia can complement each other. As he puts it,

Perhaps the history we see cannot avoid having a Chinese interpretation and understanding. So, when we put together these global pictures from different perspectives, isn't it comprehensive? Therefore, when we talk about global geographical discoveries, we do not take Zheng He's voyages to the West as a great geographical discovery to belittle Columbus and Magellan (this is a China-centric position), but say that Zheng He's sailing west was mainly meant to promote the prestige of the Celestial Empire and not to promote the global exchange of goods and cultures. Therefore, there is no promotion of a ‘great geographical discovery’ in the true sense.<sup>14</sup>

---

<sup>12</sup> Conversation with the Author on 31 March 2022.

<sup>13</sup> See the introductory text to the above-mentioned podcast *Cong Zhongguo chufa de quanqiu shi* 从中国出发的全球史 (Global History from the Perspective of China).

<sup>14</sup> Conversation with the Author on 31 March 2022.

Finally, he also takes into account the fact that when the Chinese listen to historical narratives, they tend to feel closer to things that are familiar to China and thus easier to understand. So, he starts from a selection of Chinese stories to recount Global History as audio programme. For example, the 'Silver Age', i.e. the age of mining and trading silver, was a major event which involved the Americas, Europe, and Asia after the fifteenth century. When talking about this, Prof. Ge refers to a recent archaeological discovery in China, the "Jiangkou sunken silver", which refers to a large amount of silver hidden at the bottom of a river when the peasant army lost a battle at the end of the Ming dynasty.<sup>15</sup>

As in China people had used silver as currency since the late Ming dynasty, a shortage had been caused. This easily triggers the familiarity of the Chinese audience (or readers) and helps them understand. Of course, because it is the ear that listens to the sound and not the eye that reads the text, it is also very important that this kind of history programme through an audio (podcast) platform uses a short, relaxed, and lively narration, and that the content tells a story instead of speaking big truths, avoiding being too academic and using everyday language instead. To this end, I spent a lot of time and energy revising and supplementing the manuscript. Many listeners left messages and comments, saying that the program changed their understanding of global history, subverted the historical view in textbooks, opened up their own outlook on the world, and changed their self-centred worldview. This is very comforting to me.<sup>16</sup>

Another attempt to include China in Global History is that of the aforementioned journal *Global History and China*. It also performs the function of spreading the approach of World History/Global History, although limited to the academic field. Specifically, its intention is to contribute to definitively overcoming the disciplinary boundary between the history of China and the history of the rest of the world, integrating Chinese history into global history and aiming to understand history through interactions. This disciplinary boundary is still dominant in the way history is taught at the various school levels in the PRC. The journal *Global History and China* places particular attention on the history of ideas, knowledge transfer and scholarly exchange, as well as the cultural and linguistic contact between the East and the West.

<sup>15</sup> Cf. *Baiyin shidai: faxian xin dalu yu quanqiu maoyi* 白银时代: 发现新大陆与全球贸易 (Silver Age: Discovering the New World and Global Trade), podcast *Cong Zhongguo chufa de quanqiu shi* 从中国出发的全球史 (Global History from the Perspective of China), no. VI.2.

<sup>16</sup> Conversation with the Author on 31 March 2022.

In his preface to the first issue of the journal, Li Xuetao refers to the great example of Xu Guangqi (徐光启; 1562-1633), as a precursor of a fruitful method of cultural interaction, summarised in the formula “translate-integrate-overcome (*fanyi, huitong, chaosheng* 翻譯, 會通, 超勝)”, coined by Xu Guangqi himself at the end of the Ming era (Li 2013, 56). This example refers to the experience of cultural exchanges carried out by European Jesuit missionaries and Chinese scholar-officials at the beginning of the seventeenth century. According to Ge Zhaoguang, this experience would mark the beginning of a turning point in the overall view of the outside world that Chinese culture expressed. Despite the intense intercultural exchanges of previous eras, the maps drawn by the Jesuits, and Ricci in particular – and the transmission of their scientific knowledge more generally –, would have posed a decisive challenge to Chinese scholars, some of whom would have, from that moment on, begin a slow process of abandoning their traditional Sinocentric view (Ge 2018, 28-49).

In conclusion, nowadays the World History/Global History approach could seriously challenge the narrative of the uniqueness of Chinese history and its exceptionalism, as well as the narrative of the external world's views of the Chinese tradition and of the views of the twentieth-century Chinese historiography that spring from nationalism and anti-Western victimhood. It is then not only a matter of questioning the ingrained habit of considering the history of the world as a history of countries outside China, but of developing new conceptions that are able to go beyond a methodology that remains tied to nationalistic views, despite strong political pressure. It is evident that the World History/Global History approach promotes a deep and less conflictual understanding of the recent past.

## Bibliography

- Conrad, S. (2016). *What is Global History?*. Princeton; Oxford: Princeton University Press.
- Fan, X. (2021). *World History and National Identity in China: The Twentieth Century*. Cambridge: Cambridge University Press.
- Ge Zhaoguang 葛兆光 (2017a). *Here in 'China' I Dwell: Reconstructing Historical Discourses of China for Our Time*. Leiden: Brill. Original ed.: *Zhai zi Zhongguo: Chongjian youguan 'Zhongguo' de lishi lunshu* 宅兹中国: 重建有关‘中国’的历史论述. Beijing: Zhonghua shuju.
- Ge Zhaoguang (2017b). *Lishi Zhongguo de nei yu wai* 歷史中國的內與外 (The Interior and the Exterior in Historical China). Hong Kong: Xianggang zhongwen daxue chubanshe.
- Ge Zhaoguang (2018). *What is China? Territory, Ethnicity, Culture, and History*. Cambridge-London: Harvard University Press. Original ed.: *He wei Zhongguo? JIangyu, minzu, wenhua yu lishi* 何為中國? 疆域, 民族, 文化與歷史. Hong Kong: Niujin daxue chubanshe.

- Ge Zhaoguang (2020). "The Evolution of a World Consciousness in Traditional Chinese Historiography". *Global Intellectual History*, 7(2), 207-55.
- Ge Zhaoguang (2021). *Dao houtai kan lishi xiezhuang 到后台看历史卸妆* (Behind the Scenes: Watching History Disrobe). Chengdu: Sichuan Renmin Chubanshe.
- Li Xuetao 李雪涛 (2014). "Cong pubianshi, shijieshi dao quanqiuoshi" 从普遍史·世界史到全球史 (From Universal History and World History to Global History). *Zhonghua Dushu Bao 中华读书报* (China Reading Weekly), 17 december, 18. [https://epaper.gmw.cn/zhdbs/html/2014-12/17/nw.D110000zhdbsb\\_20141217\\_1-18.htm](https://epaper.gmw.cn/zhdbs/html/2014-12/17/nw.D110000zhdbsb_20141217_1-18.htm).
- Li Xuetao 李雪涛 (2021). "Zhongwai guanxi shi cai shi zhenzhengde shijieshi" 中外关系史才是真正的世界史 (The History of Sino-Foreign Relations Is the Real World History). *Shanghai Shifan Daxue xuebao* (zhexue shehui kexue ban) 上海师范大学学报 (哲学社会科学版) (Journal of East China Normal University (Humanities and Social Sciences)), 3.
- Liu Xincheng 刘新成 (2009). "Hudong: Quanqiu shiguan de hexin linian" 互动: 全球史观的核心理念 (Interaction: The Core Idea of Global History). *Quanqiuoshi pinglun 全球史评论* (Global History Review), 2, 3-12.
- Liu Xincheng (2012). "The Global View of History in China". *Journal of World History*, 23(3), 491-511.
- Maurel, C. (2013). "Faire de l'histoire mondiale/globale en Chine à l'heure de la mondialization". *Revue Tiers Monde*, 4(216), 19-43.
- Perez-Garcia, M. (2021). *Global History with Chinese Characteristics: Autocratic States along the Silk Road in the Decline of the Spanish and Qing Empires 1680-1796*. Singapore: Palgrave Macmillan.
- Sachsenmaier, D. (2011). *Global Perspectives on Global History: Theories and Approaches in a Connected World*. Cambridge: Cambridge University Press.
- Samarani, G. (ed.) (2019). *La Cina nella storia globale. Percorsi e tendenze*. Milano: Guerini e Associati.
- Samarani, G.; De Giorgi, L. (2005). *La Cina e la Storia. Dal tardo impero ad oggi*. Roma: Carocci.
- Spakowski, N. (2009). "National Aspirations on a Global Stage: Concepts of World/Global History in Contemporary China". *Journal of Global History*, 4(3), 475-95.
- Wang, Q.E. (2018). "Re-Presenting Asia on the Global Stage: The Rise of Global History Studies in East Asia". Beckert, S.; Sachsenmaier, D. (eds), *Global History, Globally: Research and Practice around the World*. London: Bloomsbury, 45-66.
- Xu, L. (2010). "The Rise of World History Studies in Twentieth-Century China". *History Compass*, 8(8), 780-9.
- Zhang Xupeng 张旭鹏 (2020). "Quanqiu shi yu minzu xushi: Zhongguo tese de quanqiu shi heyi keneng" 全球史与民族叙事: 中国特色的全球史何以可能 (Global History and National Narrative: The Possibility of a Global History with Chinese Characteristics). *Lishi yanjiu 历史研究* (Historical Research), 1, 155-73.

**The Historian's Gaze**

Essays on Modern and Contemporary China  
in Honour of Guido Samarani

edited by Laura De Giorgi and Sofia Graziani

# China's Ethnic Relations in Historical Perspective: From the Qing to the People's Republic

Yu Shen

Indiana University Southeast, USA

Larry Shyu

University of New Brunswick, Canada

**Abstract** The geographical region known as 'China' has historically been inhabited by many ethnic groups, with the Han (漢) emerging as numerically the largest. Throughout China's history, ethnic relations have been the most important issue, with direct bearing on political unity or division, war or peace in the region. China's ethnic relations were marked by incessant conflicts and incorporations between the majority Han and other ethnic groups, or by fighting and integration among the minority ethnic groups themselves. This essay reviews the intricate, historical evolution of China's ethnic relations in the modern period from the Manchu Qing dynasty (1644-1911) to the People's Republic. We focus on the formulation and implementation of the 'nationality policy' by the central governments, investigating policy intentions, goals, strengths, and weaknesses. Special attention is paid to some sensitive regions and ethnic groups.

**Keywords** Minzu (ethnicity and nationality). Autonomy. Segregation. Migration. Minority regions.

**Summary** 1 Defining the Term *Minzu* (民族). – 2 Before the Qing Rule: No Consistent Ethnicity Policy. – 3 The Qing: Formulating a Consistent Ethnicity Policy (1644-1911). – 4 The ROC: Reformulating a Modern Policy (1912-49). – 5 The PRC: Creating Its Nationality Policy (1949-90s). – 6 Conclusions.



**Sinica venetiana 10**

e-ISSN 2610-9042 | ISSN 2610-9654

ISBN [ebook] 978-88-6969-723-4 | ISBN [print] 978-88-6969-724-1

**Peer review | Open access**

Submitted 2022-07-26 | Accepted 2022-12-07 | Published 2023-10-11

© 2023 Shen, Shyu | © 4.0

DOI 10.30687/978-88-6969-723-4/004

## 1 Defining the Term *Minzu* (民族)

Let us start with an anecdote. A friend, whose ethnicity is different from his nationality, said he would, when asked, identify himself as Chinese in *ethnicity* and Malaysian in *nationality*. This anecdote calls our attention to the different meanings of these two Chinese terms - 'ethnicity', translated as *minzu* (民族); and 'nationality', translated as *guoji* (国籍). Different in Chinese, the two terms are alternatively used in English. We are trying to understand the Chinese term *minzu*, its origin and its evolution in history, and its various English translations, in order to start our investigation into the so-called 'nationality problem/issue' (*minzu wenti* 民族问题).

There is no consensus among Chinese scholars as to when the two-word term *min-zu* came into being, whether the term originated from the Chinese language itself or was a borrowed expression. The Chinese Encyclopedia sources the term to Liang Qichao, who in 1903 introduced the concept of 'nationalism' from Germany to China, as an appeal to the Chinese to fight against imperialist encroachment as a united Chinese *minzu*. More meticulous research into the vast volumes of Chinese historical records and literature, with the help of e-technology and capacity, has revealed the term *minzu* in this exact form appeared as early as the 400s AD. In the Chinese context, the term denotes the genus of clan (*zongzu zhi shu* 宗族之属) and differentiates between Chinese and barbarians (*hua yi zhi bie* 华夷之别) (Hao 2004).

The importance of tracing the origin of this term does not lie with its linguistic ascendancy; rather, it is about the concept, the meaning it signifies and how it is understood by the Chinese people in its historical context. In this respect, a general consensus exists among Chinese scholars. It is not surprising that it was during the turn of the nineteenth and twentieth centuries, when China was in crisis, that the concept of *minzu* entered the Chinese consciousness and played a significant role in defining the target of the Revolution led by Sun Yat-sen. By this time, *minzu* was infused with connotations that were not incorporated in its original meaning. The word 'people' (*ren* 人) as in 'Manchu people' (*manren* 满人) and 'Han people' (*hanren* 汉人) were on the way to become *Manqing minzu* (满清民族) and 'Chinese *minzu*' (*Zhonghua minzu* 中华民族). This transformation in the language demonstrated the influence of the Western concept of 'nation-state', or one nation, one state. As a result, the Chinese term *minzu* could have several different equivalents in the English language, each embodying layers of implications, political and cultural (Ma 2013).

As the term *minzu* was more widely adopted by the Chinese, its usage was still confusing. For example, the radical faction among the revolutionaries after 1911 advocated restoring the eighteen provinces as the new republic, which were composed of the Chinese nation

or *minzu* (中华民族), excluding other peoples. In the end, the Republic of Five (Nationalities) (*wu zu gonghe* 五族共和), a more inclusive agenda, won, over the narrowly defined Chinese nation as composed of the Han people only. Sun Yat-sen's nationalism (*minzuzhuyi* 民族主义), as one of his Three Principles of the People, defines nationalism as 'country-zu-ism' (*guozuzhuyi* 国族主义). The two terms co-existed during the Republican era until the People's Republic decided *minzu* would be the official term. Since then, the term 'Chinese nation', or *Zhonghua minzu* (中华民族), embraces the diverse populations living in China.

While *minzu* is uniformly used in China, its English equivalents are multiple: nation, nationality, ethnicity, ethnonational groups, people, or even race. In this essay, the Chinese term *minzu* will be used alongside its various English translations.

## 2 Before the Qing Rule: No Consistent Ethnicity Policy

Although ethnic relations were of utmost importance to the stability and survival of a dynasty in China, most dynasties before the Qing never developed a systematic and long-term policy in the management of ethnic relations. As the Han nationality had formed an absolute majority in number, the Han ruling house adopted policies variably, depending on the status of its political power. When it was strong and unified, its policy towards non-Han peoples tended to rely on its military power to either drive them out of China's territorial confines or to establish military settlements on the frontier, forcing peoples on the borderlands to assimilate or resettle further inland. This approach was more often applied to the North or Northwest of China. The Han rulers may also adopt a seemingly more peaceful and benevolent policy in the South and the Southeast. For example, the imperial court would, on surface, recognise the existing political structure under the rule of various chieftains (*tusi* 土司), while flooding these frontier regions with numerous Han settlers. After Han settlers reached sufficient numbers, formal local administrative structures would be created with tax and *corvée* labour obligations and direct central administrative control. This is known as *gai-tu gui-liu* (改土归流) in the historical term.

The Mongol Empire of the Yuan in the thirteenth century stood out in China's imperial history as one composed of non-Han minority ruling a land with the Han majority and many other groups. It showed differentiated approaches to various groups under its rule, but did not formulate an official nationality policy. In practice, the Mongol ruling class adopted a rather rigid discriminatory racial policy, placing the Han, a majority people, at the bottom of the political-social scale. In contrast, the Mongols treated peoples of Central Asia and

of Tibet with more respect and trust. For example, many hereditary ruling houses in Central Asia were granted Mongol noble ranks and even inter-married with members of the Mongol ruling class.

With Tibet, Mongols expressed respect to Tibetans' Lamaism. Of course, such an attitude was based on both practical and political considerations. The Tibetan plateau, so mountainous and high in altitude, was extremely difficult for the Mongol cavalry to conquer by force. Showing a special favour to the religion of the Tibetans was a way to win the support and allegiance of the leaders and people of Tibet. Eventually most Mongols became followers of Lamaism, and the Tibetans returned their rulers' fairness by offering their loyalty to the Mongol Khan.

The Ming dynasty, which succeeded the Yuan, returned to a Han-centred nationality policy, and the Ming rule was largely confined to regions inhabited by the Han people. Not until the Manchus became new rulers of China would there emerge an ethnicity policy created and managed by the central government.

### **3 The Qing: Formulating a Consistent Ethnicity Policy (1644-1911)**

An overview of various components of the Qing's nationality policy highlights these core concerns and approaches: religion, segregation, and appeasement through marriage. With these key components in mind, the following review will focus on the policy's implementation in three regions in particular - Mongolia, Tibet, and Xinjiang.

It may seem that the Qing inherited the Mongol policy of granting special favour to the Tibetans. However, the Qing had developed its ethnicity policy based on its own historical experience of having co-inhabited with multiple ethnic groups for generations in the Changbai Mountains before rising to become the dominant people in the region of China's Northeast. In the year 1635, these people created the name of *Man* (滿) to mark the birth of an ethnically amalgamated nation. The adoption of the name *Man*, aka 'Manchu' in English, therefore provided a unified new identity for different ethnic groups in the northeast region (Rigger 1995).

Unified, Manchu people successfully conquered China, along with Mongolia, Xinjiang, and Tibet. Facing the majority Han population, as well as other nationalities now under its dominance, the ruling house soon realised that it needed to adopt a consistent nationality policy to both recognise the complex composition of the population in the newly created empire and to secure its own political control over the empire.



### 3.1 Religion: Tibetan Lamaism and Islam

One key component of the Manchu's nationality policy was its management of religion. The ruling house recognised Tibetan Lamaism, particularly the Yellow Sect, as being widely accepted by Tibetans and Mongols. The religious leaders known as 'Living Buddhas' were located widely in Tibet, Qinghai, and Inner and Outer Mongolia. In recognition of this fact, the Manchu royal court showed great respect to those Living Buddhas, particularly to the Dalai Lama, the most prestigious among the followers of this religion. The royal court extended invitations to the Dalai Lama to visit Beijing several times. The official visit of the Dalai Lama to Beijing in 1653 turned out to be a grandiose reception, marking the high plateau of the special favour shown to a religious leader.

History reveals the reason for this special treatment. In the early part of the seventeenth century the Dzungar Mongols, rivals to the Manchu power, established a powerful nomadic empire in present-day Northern Xinjiang. The Dzungars had a close relationship with the Dalai Lama. The Manchu rulers were aware of this tradition, and they wanted to pull the Dalai Lama away from the Dzungars. By the early eighteenth century, when the Manchu Qing Empire had completely defeated the Dzungars and established military control over Tibet, it changed tactic. The Qing court began to promote the status of the Panchan Lama as well as other Living Buddhas in Qinghai and Mongolia, to make them nearly equal to the Dalai Lama. Furthermore, the Qing court proclaimed strict regulations regarding the choice and recognition of the 'reincarnates' of all Living Buddhas, including the Dalai Lama. The Qing proved to be simultaneously sensitive and respectful, as well as forceful and authoritarian, in its approach to Tibetan religious affairs (Xiao 1962).

As for Islam, the imperial court restrained itself from interference during the early years of its rule. It adopted a non-interference policy towards Muslims and even provided police protection to Islamic leaders and to various mosques. However, beginning from the reign of Emperor Qian-long (1735-96), the empire experienced a series of revolts by the Muslim population in Northwest. By suppressing the uprisings, the Qing court began to tighten its control over the Muslim population and abandoned the 'hands-off' policy of the earlier time (Zhang 2001).

### 3.2 Segregationist Policy

Beyond a religious policy, the imperial house also developed a policy of segregation with rigid control over the various ethnic groups that inhabited the vast regions of Mongolia and Xinjiang. For the rule of the Mongols, the Qing largely followed the traditional division of *qi* (旗), or 'Banner', which numbered about 200 different Banners. People living in each Banner had a designated geographical area and were not allowed to cross into the territory of another Banner. Leaders of these Banners were hereditary, known as 'Zhasake', or Zasad. They were given the power of administrative control and taxation. However, each Zasad must be appointed and sanctioned by the imperial court and given a noble title.

The Qing administrative policies over Tibet and Xinjiang were similar to those in Mongolia. Tibet was administratively divided into four parts, each headed by a hereditary Tibetan nobleman known as a 'Gebulun', but each must receive official appointment from the Qing court. The same was true for the various 'oasis cities' in Xinjiang; each was headed by a Beg as its administrative chief, and all received appointment from the imperial court and were provided with stipends. However, the Muslim Begg were not accorded the same high respect shown to the Living Buddhas of Lamaism.

On the whole, with the exception of the military suppression of the Dzungar uprisings previously mentioned, the segregationist policy that managed the vast regions of different ethnic groups was relatively successful in maintaining peace and control for the Qing court (Xiao 1962).

The Qing's segregation policy extended to the operation of its own military. For example, Qing troops stationed in various parts of the vast territory were segregated by categories, such as Manchu Banner troops, Mongol Banner troops, Han Banner troops, and Han soldiers of the Green Battalion (*luying* 绿营). They all had separate barracks and were not allowed to make direct contact with each other or with the local civilian population.

In social and economic life, Han immigrant farmers in Eastern Xinjiang were not allowed to live in Muslim areas or intermarry with Muslims. Han merchants must obtain special permission and a kind of passport before being allowed to enter Xinjiang. Merchants from Central Asia could come to Xinjiang only with special permits they had obtained beforehand, and their business activities must be put under the supervision of the local authorities. Such a rigid segregationist policy was maintained until the 1860s (Lin 1988).

A similar segregationist policy was also imposed over Tibet. After the Dzungars were defeated and their influence eliminated, the Qing court began to station troops in important areas in Tibet to inspect all persons entering Tibet. Members of the Mongol nobility

who wished to visit Tibetan high-ranking clergy for religious matters must request permission for their journey from the Qing court. Han or Mongol merchants must also obtain permission from the authorities to enter Tibet. The same policy applied to Tibetan clergy or nobility trying to travel to Mongolia or inner parts of China.

The segregationist policy adopted by the Qing court was installed to maintain national stability and safeguard the peace and security of the frontier regions. Such a policy of controlling contacts among different ethnic and religious groups was conceived to prevent potential conflicts among various groups of the population. Some may consider this policy an ultra-conservative strategy to uphold the political, economic, and cultural status quo, leaving no room for change and development.

### 3.3      **Appeasement Through Marriage**

Combined with the harsh and restrictive policy of segregation was the Qing's reliance on the practice of intermarriage between imperial court members and members of leading families among selective minority groups. Noble ladies of the Mongol, Tibetan, and Uyghur families were encouraged to marry young members of the Manchu nobility; and Manchu princesses, through royal arrangement, were married to leaders of ethnic minority groups important to the Manchu royals. This intermarriage tradition had been long established since even before the Manchu conquest of China led by Nurhaci (1559-1626). A particular subgroup of the Mongols, the Horqin Mongols in Eastern Mongolia, was accorded special attention. Through several generations of high-level intermarriages, many Horqin Mongol ladies became mothers to younger generation Qing emperors. This kind of intermarriage guaranteed the high loyalty of the Horqin Mongols to the Qing imperial house (Xiao 1962).

In addition to the practice of intermarriage at the top level of the ruling class, the Qing court also adopted the policy of ennoblement and official appointment for traditional leaders of the Mongols, Tibetans, and Uyghurs. They enjoyed near equal status of high-ranking Manchu nobility. They were also richly rewarded with an annual salary and periodic permission to journey to Beijing to have imperial audience as a special honour (Lin 1988).

### 3.4      **Policy Assessment and Legacy**

The importance of Mongolian and Tibetan affairs in the Qing nationality policy was essentially based on political and strategic considerations. The early expansion of Manchu power would not have been

possible without the support of eastern Mongol tribal groups. After the establishment of the Qing Empire, the imperial court was most concerned with the peace and security of its vast frontier regions, mostly inhabited by the Mongols, Tibetans, and Uyghurs. As early as 1636, before the Manchu's conquest of inner China, the Manchu ruler Huang-tai-ji (皇太极) ordered the creation of the Office for Mongolian Affairs. Two years later, its name was changed to *Li-fan Yuan* (理藩院), or 'Bureau for the Management of Dependency Affairs', mainly in charge of Mongolian affairs. During the reign of Emperor Kang-xi (1661-1722), the authority of this bureau was expanded to include Tibetan and Xinjiang affairs and its status was elevated to that of the Six Ministries in the government. It took charge of such matters as arranging imperial audiences of all Living Buddhas and members of high nobility, the distribution of food and money for disaster relief, and the settlement of local judicial matters in Mongolia, Tibet, and Xinjiang (Zhao 1986).

The Qing policy for the control and management of Mongolian and Tibetan affairs was fairly successful. The Mongols and Tibetans remained loyal to the Qing imperial house, and peace and stability were largely achieved in these regions throughout the Qing dynasty. In contrast, the Qing policy towards other ethnic minorities in the empire was difficult and often caused disturbances and even rebellions. The main reason for these conflicts was the oppressive and exploitative nature of the Qing policy. Ethnic minorities had to pay heavy taxes and were forced to serve *corvée* labour. In various areas of the Southwest, ethnic minorities lived side by side with Han people, but local officials were often biased in favour of the Han when settling disputes between them. By the nineteenth century, when the dynasty was showing signs of decline, ethnic minority groups in the Southwest often rebelled against the central authority. From the 1850s to the 1870s, there were prolonged rebellions of the Miao people in Guizhou and of the Hui in Yunnan (Guo 1980).

The least successful minority policy of the Qing was its policy towards the Hui people. During the High Qing era between late seventeenth century and the late eighteenth century, the imperial policy towards Muslims in Xinjiang was moderate and tolerant. However, its policy towards the Hui was problematic. The Hui people were descendants of Muslim trader-merchants who settled in various parts of China long before the founding of the Qing dynasty. They were culturally and linguistically amalgamated with the Han, and most adopted Han surnames. However, they managed to retain their religious belief and continue to observe the Muslim dietary tradition (Yang 1988). Anti-government incidents of Hui people occurred in Gansu and Qinghai during the eighteenth century. Such incidents were sometimes caused by the rivalry between Islamic sects and sometimes by disputes between Hui and Han neighbours. Local ad-

ministrative officials often mismanaged these disputes, resulting in violence and bloodshed (Ge 2002; Zhang 2001). The most serious rebellion in the Southwest originated in Yunnan and was led by the Hui leader Du Wen-xiu (杜文秀). The conflict, which continued under the Qing authority for 16 years (1856-72), effected very high casualties on both sides. The Hui protest against the central authority soon spread to the Northwest. The Qing court appointed General Zuo Zong-tang (左宗棠) to command the newly created Hunan Army to restore order and reconquer all lost land from rebels in Shannxi, Gansu, and Xinjiang. The last of the rebellion was not resolved until the year 1877 (Ge 2002; Zhang 2001).

After more than two decades of Hui rebellions, the Qing court recognised the importance of the principle 'to use the Hui pacifying the Hui'. The imperial court began to adopt the policy of appointing local Hui leaders and enlisting Hui soldiers to maintain local law and order. This paved the way for the rise of Hui military leaders in the Northwest during the early years of the Chinese Republic (Ge 2002; Zhang 2001).

#### **4 The ROC: Reformulating a Modern Policy (1912-49)**

The Republican Revolution established the Republic of China (ROC), with the Han Chinese taking the leadership of the new regime. Due to political instability and coloured by their views of the Manchu Qing's incompetence and corruption, the new leaders of the Republic did not prioritise, nor did they have time to, develop a long-term and strategically sound nationality policy.

##### **4.1 Sun Yat-sen's Five Nationalities (*wuzu* 五族) and Chiang Kai-shek's *zongzu* (宗族)**

The success of China's Republican Revolution depended on the wave of anti-Manchu Han nationalism. However, after the Qing Empire was overthrown, the leaders of the new Republican government faced the reality of the Chinese state being a multi-ethnic country. A few leaders maintained their anti-Manchu attitude, but the most prominent leader, Sun Yat-sen, had promoted equality for all nationalities within China. Sun recognised the equality of China's 'Five Nationalities', namely the Han, Manchu, Mongol, Hui, and Tibetan. This idea was formally adopted by the new Republican government and was written into its new constitution. The new 'five-colour' National Flag (1912-27) displays red, yellow, blue, white, and black, in equal shape and size, signifying that China was a multi-ethnic nation and that each ethnicity was an equal member of the country.

The recognition of Five Nationalities obviously did not accurately reflect the much more complicated ethnic composition in China. A number of ethnic minorities in the Southwest, such as Yi (彝) and Miao (苗), were numerically larger than Manchu, Mongol, and Tibetan, but were not included in the recognised Five Nationalities. Furthermore, the use of the term *Hui* (回) during the Republican period was ambiguous. It generally referred to all Muslims, rather than a particular ethnic nationality.

One of Sun Yat-sen's Three People's Principles, the 'Principle of Nationalism' (*minzuzhuyi* 民族主义), was derived from an ideal that the Chinese nation was a great harmony of ethnic groups. Thus, the religious, cultural, linguistic, and even physical differences of the Five Nationalities were to evolve and amalgamate into one Chinese nation/nationality (*Zhonghua minzu* 中华民族). Sun's 'brand' of nationalism was largely accepted by those in power, including the Beiyang military leaders who dominated the young Republic (Zhu 1985).

Recognising these four minority nationalities - Manchu, Mongol, Hui, and Tibetan -, the early Republic demonstrated its deep concern for frontier security. The Qing court had established a special relationship with Mongol, Tibetan, and Uyghur leaders, and with their assistance, the Qing was able to secure the loyalty of their peoples to the imperial court and keep peace in the vast frontier regions. After the fall of the Manchu dynasty, such a special relationship was no longer in place, and the frontier was open to challenges and threats from these peoples.

Both the Beiyang government (1912-27) with its capital in Beijing, and its successor, the Nationalist government (1928-49) based in Nanjing, generally embraced Sun Yat-sen's idea of the Principle of Nationalism. However, a deep probing into Sun's idea of nationalism reveals more complexity to this principle of equality among all nationalities. The core of this 'equality' depends on the 'peripheral' minority peoples' eventual assimilation with a 'superior' Han Chinese (Zhu 1985; Leibold 2004).

Political leaders of the Republican period could not reconcile these two seemingly contradictory views. While Sun Yat-sen evaded making a concrete policy towards his Principle of Nationalism, Chiang Kai-shek wiped out the principle of equality between the Han and other ethnic minorities by denying the difference of all ethnic minorities. He upheld a firm conviction in Han nationalism. The book attributed to be authored by him, *Zhongguo zhi mingyun* 中国之命运 (The Destiny of China), published in 1943, unequivocally states that all nationalities in China were descended from a 'common ancestor' (*zongzu* 宗族), and therefore the Chinese (or Han) nation was a unified single nation without multiple nationalities (Jiang 1943).

## 4.2 Government's Ineffective Attempt at Formulating a Nationality Policy

Notwithstanding the policy differences between the Qing and the Republic, there was evidence of continuity in policy and practice. Both central authorities were concerned about the security of their frontiers and made efforts to secure collaboration and loyalty from people living in the vast borderlands. One example was the continued importance accorded to Mongolian and Tibetan affairs. The Republican government set up a Department for Mongolian and Tibetan Affairs. Its name later changed to the 'Commission for Mongolian and Tibetan Affairs', but was given equal status as other government ministries. Even though the power and status of this Commission could not compare with the previous Qing office, the office represented the government's continued concern and effort in appeasing these two groups.

Both the Beiyang and the Nationalist governments, in public announcement, always proclaimed republicanism and equality for all nationalities in the country. However, there was little real progress towards a concrete nationality policy. In his idea of the Principle of Nationalism, Sun Yat-sen mentioned the right of self-determination for ethnic minorities, but the central government during the Republican period never officially acknowledged this right in its constitution or law codes (Zhu 1985).

Ideology aside, China's Republican government faced the imminent challenge of the separation of these two regions - Mongolia and Tibet -, from the very beginning. The political instability of the central government, coupled with the imperialist powers' active attempts at influencing and controlling Mongolia and Tibet, resulted in Mongolia and Tibet declaring independence from China in 1912. The Beiyang government responded with military pressure to try to restore China's sovereignty in these two regions, but it was severely limited by its own weakness as well as the fear of military intervention from Russia and Britain. Eventually, through the mediation of these powers, a compromise was reached that favoured Britain and Russia's position, with Mongolia and Tibet maintaining their own separate status but recognising China's suzerainty (Guo 1979).

The other immediate challenge to China's integrity came from the Hui. Acknowledging Hui people's broad-based discontent with the Qing rulers, the early Republican government reached out to the Hui's local leaders, offering a conservative policy of maintaining the status quo and appointing them as government officials at both provincial and central levels. To demonstrate the government's acknowledgement of the distinction between the Uyghurs who were Muslims and non-Uyghur Muslims elsewhere, a new term was created to refer to the Uyghur Muslim: *Chan-Hui* (缠回, 'Muslims with Head-wraps'). In the early years of the Republic, the term of *Huizu* (回族), or the

'Hui nationality', was used to refer to the Uyghurs, whereas those other non-Uyghur Muslims living elsewhere in China and linguistically using Han language were referred to as *Huimin* (回民), or the 'Hui people'. At times confusing, these terms demonstrate the Chinese central government's intention to recognise the differences among various groups of minorities and its attempt to formulate a nationality policy that would reflect these distinctions. These terms were in use well into the 1950s (Ge 2002).

The Hui co-inhabited vast regions of China's western and north-western frontiers with other ethnic groups. In many areas they did not form a majority and therefore were ruled by Han or other ethnic groups. In their apprehension of being oppressed, the Hui began to establish their own local military organisations for self-protection. Gradually the Hui military organisations expanded and gained power and influence. By the early years of the Republic, the Hui military leaders became local rulers of Ningxia, Qinghai, and Gansu Provinces. This situation lasted more than three decades. The Nationalist governments not only tolerated the situation but sought close cooperation with the Muslim Hui rulers. This occurred because a new and more menacing threat to the Nationalist government emerged, that of the CCP. Because the Hui leaders were Muslim and fundamentally anti-Communist based on religious grounds, they became reliable allies of the central government. They served as vanguards in the battleground defending the Nationalist government against the CCP and its troops (Shi 1989; Chen 1981).

The history of the whole Republican period was long on intentions and short on concrete results. Incompetency was one of the problems, but constant and numerous conflicts caused by political division and fragmentation, frequent civil strife, and the intervention and invasion of foreign imperialist powers deprived the government of time and energy to focus on this important issue. From 1912 to 1949, China faced severe and relentless challenges. It was left without any real power to initiate a new and effective nationality policy.

### 4.3 Nationality Issue Under the Japanese Invasion

The outbreak of an all-out Anti-Japanese War in the summer of 1937 brought urgency to the very survival of China as an independent country. The utmost priority for the central government was national unity to fight the powerful invader. It appealed to all ethnic minorities to support this effort. Overall, a lot of members of minority groups joined China's war effort (Li 1999). There were, however, at least two serious cases of minority groups trying to break away from China and gain independence during the Anti-Japanese War period.



The first case was Mongolian separatism. The movement began in 1933 after the Japanese occupation of Manchuria, when the Japanese Kwantung Army advanced into Inner Mongolia. Led by Mongol Prince De-wang (德王), a group of Mongol noblemen took advantage of this moment of weakness of the central government and appealed for a high degree of 'self-determination'. When they did not receive a satisfactory reply, they began to communicate with the Japanese military authority and obtained Japanese financial and military help. In May 1936, they declared the formation of the 'Mongolian Military Government'. After the outbreak of the Anti-Japanese War, a Mongolian army under the command of Li Shou-xin (李守信) openly assisted the Japanese army. In 1939, a 'United Mongolian Self-Rule Government' declared its formation in Zhang-jia-kou, with Prince De-wang as its head. This collaborationist regime became the earliest puppet regime under the control of the Japanese military. The regime came to its natural termination when Japan surrendered in August 1945 (Yasui 1989).

The second serious incident happened near the end of the war period. In September 1944, a group of Kazaks in northern Xinjiang raised a separatist banner against the central government. Their justification was heavy taxation. This movement soon spread to Uyghurs who formed the majority population in Xinjiang. Before the end of the year, the rebel forces declared the formation of the 'Provisional Government of East Turkestan People's Republic'. The Nationalist government was unable to suppress the movement by force, and the negotiation for a settlement led nowhere until 1949. When the People's Liberation Army units entered Xinjiang in October 1949, the separatist movement came to an end (Ge 2002).

However, it is inaccurate to believe that all Hui people in China desired separation from China. During China's Anti-Japanese War, the Hui identified with China's war aim and participated in its war effort. Between 1937 and 1941, Hui and Uyghur organisations in China sent several 'visitation missions' to various places in Southeast Asia and the Middle East to inform fellow Muslims of the true nature of Japan's aggression in China. These missions directly countered Japan's propaganda of being a good friend and ally to the whole Muslim world and solicited support for China's cause. Although we have no definite proof of the effectiveness of this counter-propaganda effort, these visitations did cause special Japanese attention and made Japan aware that its policy of seeking Muslim support had its limitations (Bao 2020).

## 5 The PRC: Creating Its Nationality Policy (1949-90s)

In comparison to the ROC, the PRC developed a complex set of policies, laws, and rules, and established approaches and practices to manage the country's vast population, of which nearly 9% are identified as 'minority nationalities' and more than 91% are of the Han nationality, in a country with 1.4 billion population.

### 5.1 Early Policy and Its Theoretical Foundation

In the early days of the Chinese Communist Revolution from 1929 to 1934, the Party did not develop its own nationality policy but generally followed the Marxist principles and the nationality policy of the Soviet Union. As a party confined to limited space and with little freedom to traverse the vast territory, the CCP had little experience dealing with ethnic groups. This changed during the 'Long March'. The march forced the Communists into remote areas to flee from and evade the Nationalist pursuit. There, they encountered various minority groups whose cooperation and assistance were essential to the CCP's survival. This experience led the Party's leadership to realise the necessity of having its own nationality policy with the goal of winning the support of the broad ethnic population.

At the end of the Long March, the CCP re-established its base area of control in northern Shaanxi, a region long inhabited by many Mongol and Hui people. Not having formulated a consistent nationality policy, the CCP nonetheless took on the task of reaching out to these two groups of people. On December 20, 1935, the 'Central Government of the Chinese Soviet' issued a declaration specifically addressing the Mongol population in Inner Mongolia to support their fight against the Japanese and to ask for their collaboration with the Red Army. A few days later, Mao Zedong made a speech reconfirming the message previously issued:

The minority people, particularly the Mongols in Inner Mongolia, are under the direct threat of Japanese imperialism. They are rising in their struggle. Their future is tied closely to the struggle of Chinese people in north China and the struggle of the Red Army in China's northwest. (Quoted in Yasui 1989)

With the Hui people in Ningxia, the Party had a different call. Ningxia at the time was outside the path of the Japanese advancement, and the CCP appealed for Hui's support of the Party's political and social agenda of land reform.

After the outbreak of the all-out Anti-Japanese War, the CCP gradually developed its United Front policy, which, in regard to ethnic

minorities, aimed to gain support to fight against Japan as well as rivals against the Nationalist government. Under this policy, the CCP declared its respect for the special characteristics of the minority peoples in terms of religion, languages, and social customs. It recognised the existing political system and leadership of the ethnic minorities and promised them complete equality under the law. The core of the policy was still under the influence of the Soviet Union, which recognised national self-determination.

In the Sixth special session of the CCP's Sixth National Congress held in November 1938, Mao Zedong made the following remarks:

[We] allow equal rights to Mongol, Hui, Tibetan, Miao, Yao, and Yi people with the Han. Under the principle of a United Front against the Japanese, minority people have the right to administer their own affairs and establish a united country with the Han. (Quoted in Chen 1986)

The CCP's implementation of this policy was first aimed at the Mongols in Inner Mongolia and the Hui people in Ningxia. The Party established a 'Mongolian Working Commission' and a 'Frontier Stabilisation Working Commission' to investigate the economic and social conditions for each group, respectively. In Yan'an, the Party created a training centre for the youth of minority peoples. Later, the Party established self-governing Mongol and Hui counties and villages. These policy developments laid the foundation of CCP's nationality policy after it won political control of the whole country in 1949 (Yasui 1989).

## 5.2 The Three Pillars of the Nationality Policy Since the 1950s

With the founding of the People's Republic of China (PRC) in 1949, a more systematic nationality policy was developed by the CCP. At the core of the policy was the principle of equality among peoples, or *minzu*, recognising their unique identities distinguishable from the Han people. This was in contrast to the Nationalist argument that China was home to only the 'Chinese people' (*Zhonghua minzu* 中华民族), and other groups were merely sub-varieties of a 'common heritage' (*zongzu* 宗族).

Still under the influence of Marxism and the Soviet example, the CCP initiated the 'Ethnic Identification project', or *minzu shibie* (民族识别), as the first of the three main pillars of its nationality strategy. Over a course of three decades, this project engaged many Chinese social scientists, who travelled into the areas where minority peoples lived, to identify and determine ethnonational composition of the country. Out of more than 400 groups applying for the *minzu* identity, 56 distinct peoples emerged as the 'finalists'. The phrase of "56

*minzu*" came into being in 1979, when the 56th group, that of Jinuo people (*Jinuo* 基诺族) was added to the list of 55. Despite criticism of the soundness of the investigation, this number and definition became official and is widely used in the present day (Mullaney 2012).

The second major pillar in China's ethnonational management was the establishment of 'autonomous regions' under the principle of self-governance for ethnic minorities. In fact, two years before the founding of the new regime, the CCP had already established an 'Inner Mongolia Autonomous Region'. After the founding of the PRC, four other autonomous regions were established. These five autonomous regions were top-level administrative units, equivalent to provinces. At the second administrative level were 31 autonomous prefectures, overseeing about 120 autonomous counties and banners with several thousands of townships. These autonomous regions occupy 64% of the total territories of China (Chen 2002).

The theoretic foundation for the establishment of all autonomous units was laid by Li Weihan (李维汉), who served as Minister of the United Front Department at the time. Li was not agreeable to the adoption of the Soviet model of 'Nationality Republics'. He insisted that the best policy was the creation of autonomous units under a centralised national government. He explained that China's minorities often had mixed habitation, and the total number of ethnic minorities occupied a relatively low percentage of China's total population. The conditions, therefore, were different from the Soviet Union. He further argued that ethnic minorities in China were a part of China's revolutionary process to expel imperialist influence and gain national unity and liberation. Therefore, the ethnic minorities must first achieve a 'democratic revolution' to abolish serfdom and feudal institutions. Then, the second step of the revolution would be 'socialist', in the realisation of socialism (Li Wei-han, quoted in Chen 1986).

Li's suggestions were accepted by the CCP leadership, and the framework was reflected in 'The Common Programmes' of China's People's Political Consultative Congress adopted in September 1949. It stated: "In areas inhabited by national minorities, the programme of self-governance be implemented. In accordance with the number of population, various autonomous units will be established". This principle of self-governance for national minorities was adopted into the country's basic law in 1952, and later written into the Constitution of the PRC in 1954. However, the process of setting up various autonomous regions was not without dispute. The best example was Guangxi, which was inhabited by numerous minorities with no clear majority among them. For the establishment of a single autonomous region, a great deal of effort was made to create a new identity, the Zhuang ethnicity, incorporating several closely related minority groups. The result was the establishment of the 'Guangxi Zhuang Nationality Autonomous Region' (Kaup 2000).

The development of the autonomous regions demanded leaders from these groups who would head the top administrative position in their governments. Cadre training became both necessary and urgent. In 1951 in Beijing, a 'Central Nationality College' (*Zhonghua minzu xueyuan* 中央民族学院) was established, marking the beginning of such an endeavour. In the following decade, more than ten nationality colleges were set up in China's northwestern, southwestern, and southern regions. In 1978, the central government announced that about 800,000 minority cadres were trained. This educational work was temporarily halted during the Cultural Revolution, but it was resumed from the early 1980s with greater scope. By 1988, the government declared that a total of 1.8 million minority cadres were trained to serve as administrative and technical officials in their respective regions (Chen 1989). The number reached 3 million by the year 2004.

In addition to the training programmes, the central government also established a 'Nationality Affairs Commission' under the State Council. This Commission was supposed to direct all major affairs relating to minority regions. However, due to China's political system, the ultimate authority of state affairs lies with the Communist Party, particularly the Party's Central Committee and its Politburo. The Central Committee of the CCP had already created an executive committee to take charge of nationality affairs. Membership in the executive committee also included a few chosen from ethnic minority leaders.

In principle, training ethnic minority cadres and officials to administer the affairs of minority regions would be a positive policy. The trained cadres would serve as the medium or bridge connecting the Beijing government to respective regions and the peoples living there, and would bring to the attention of the central government any issues needed to be addressed. However, in reality, minority cadres often find themselves between two hard choices. In performing their duties, their loyalties could cause them to either lose their official position or earn disrespect from the people they call their own. This conundrum is further complicated by the presence of a large number of Han officials among them, some of whom may be their superiors.

The Third Pillar is a set of preferential policies only applicable to and possible to be enjoyed by ethnic minorities. In three areas these policies illustrate unequivocally the preferential nature of the pillar's intention. First, the central government provides financial incentives, investment, various subsidies, and other assistance to these areas. Without the support from the central government, the local governments would not have enough funds to cover their expenses. For example, in 2008, the financial assistance from the government to a local government amounted to nearly 440 million RMB, the local financial incomes stood at almost 220 million RMB, and the local government's expenses came to nearly 650 million RMB (Li, Qian s.d.).

The ethnic minority peoples also enjoy preferential treatment in the following areas: college education, job promotion, and birth rate. For the first two categories, a minority person can be admitted to college and promoted in job rank with a lower grade point or by adding additional points based on minority status - privileges not afforded to a Han peer. For birth rate, during the time when Han Chinese were strictly under the restriction of the one-child policy, minority peoples were allowed to have two children, and even when families exceeded two children, they were not subjected to local authorities' similar draconian treatment of the Han. This last privilege is moot now as China has reversed its controlling birth policy to a policy encouraging multiple births.

Even the penal code regards criminal acts by a minority person differently. The central government in 1984 approved the 'two less and one more (leniency)' policy (*liang shao yi kuan* 两少一宽): less arrest, less pursuit, and even when arrested, apply greater level of leniency.

These preferential policies purely based on *minzu* identity inevitably generates criticisms from the majority Han population. 'Unequal treatment', 'reverse discrimination', 'unfair', and even 'illegal' and 'unconstitutional' - these terms express discontent and resentment towards these preferential policies by the Han.

### 5.3 Continuing Tensions

#### 5.3.1 China's National Unity Vs. Minorities' Regional Autonomy

The CCP policy of equality for all nationalities and the principle of regional self-governance were gradually formulated in the 1950s. However, the policy was suspended during the Cultural Revolution. In fact, the section dealing with autonomy for ethnic minorities was deleted from the Constitution. After the end of the Cultural Revolution, the CCP once again placed emphasis on its nationality policy. The introduction to the newly revised Constitution in 1982 states:

The Chinese People's Republic is a united multi-ethnic country founded by all nationalities. Equality, unity, and mutual assistance under socialist ethnic relations have been firmly established and will continue to strengthen. In the struggle for national unity, we are against Greater Han Nationalism, and at the same time we are against local nationalism. Our state will do its best to promote the prosperity of all nationalities in the country.

In the Guideline of Chapter One of the 1982 Constitution, emphasis is placed on the protection of all legal rights of ethnic minorities, and it forbids discrimination and oppression against them. It allows the

establishment of autonomous administrative units in areas inhabited by ethnic minorities. And it guarantees the freedom of using their respective spoken and written languages, as well as the freedom to seek reform of their own customs. Freedom of religion was mentioned in the Constitution in general, with no particular reference to ethnic minorities (Benson, Svanberg 1998).

In 1984, China proclaimed the 'Law of National Autonomy' (*minzu quyu zizhifa* 民族区域自治法). It made no major change to the nationality policy adopted since the 1950s, reiterating the principle of equality and self-governance of the minorities. However, in Chapter Six of this 1984 *zizhifa* (自治法), under the title "Leadership and Assistance from the Superior Government Offices" (*shangji guojia jiguan de lingdao he bangzhu* 上级国家机关的领导和帮助), "Leadership and Assistance" is highlighted, implying government help is available to the ethnic minorities in developing a social system aligning to the Han majority. Obviously, the revived nationality policy did not resolve the contradiction between central control and regional autonomy or desire for political unity and respect for cultural diversity. In later years, when conflicts emerged in these regions, the government often relied on its authority to 'render guidance and assistance' to ethnic minorities, but it placed respect for their right of self-governance in a secondary position.

This is where the core problem rests: maintaining a balance between national unity and the regional autonomy of ethnic minorities. While the central government proclaims an even-handed policy of remaining simultaneously vigilant against 'Greater Han Nationalism' or 'Han Chauvinism' (*dahanzuzhuyi* 大汉族主义), and against 'regional (Nationalist) separatism' (*difang/minzu fenliezhuyi* 地方/民族分裂主义), its implementation of the policy inevitably vacillates between the two poles under different times, circumstances, and priority considerations (Yang 1990).

### 5.3.2 Han Migration into Minority Areas

Migration of the Han people into minority areas has its historical precedence but has become an acutely contested issue in the last few decades. The Qing court, in the early years of the dynasty, proclaimed a strict prohibition on Han immigration to Manchuria. Manchuria was considered the ancestral holy land for the Manchus. However, the prohibition became relaxed over the slow decline of the power of the Qing court, and it practically ended by the early years of the twentieth century. The attitude of the Qing court had changed in regard to Han immigration to Manchuria due mainly to the growing pressure from foreign imperialist powers, particularly from Russia and Japan. The net result was the mass migration of the Han people

from nearby provinces to Manchuria. This trend continued through the early years of the Republican period, with the Han farming population migrating to less populated areas of the Yellow River Loop and Manchuria in the North, and to Guangxi and Yunnan in the South. On the whole, such massive migration was voluntary and not sponsored or operated by the government.

The Han migration to frontier regions virtually stopped in the 1930s and 1940s due essentially to wars: the Anti-Japanese War and the civil war. After the establishment of the PRC, peace and social order was restored, as was the resumption of Han migration to frontier regions. The central government never formally declared a policy in favour of the migration, probably due to its concern about the sensitivity of the issue. However, judging from the massive number involved, we can safely assume that Beijing was aware of the situation and the leadership of those provinces and regions concerned probably gave their tacit approval. On one hand such migration could relieve the population pressure from densely populated provinces, and on the other hand the immigrants could help develop the local economy of the more sparsely populated regions. The other important element that the Chinese government must have viewed favourably was that the growth of the Han population in frontier regions could shift the balance of Han-minority population ratio, strengthening the centripetal trend in the frontier regions.

The Han population growth in Xinjiang after 1949 illustrates how several factors converged to create the result. In late 1949 during the final stage of the civil war, units of the People's Liberation Army (PLA) entered Xinjiang and reached a 'peaceful liberation' of the region when the Nationalist Army in garrison duties surrendered en masse. The surrendered soldiers were quickly integrated into PLA units, and most of them were ordered to serve their garrison duties in various parts of Xinjiang. In the early 1950s, with the regime consolidated and peace secured, a large number of PLA soldiers in the region were demobilised and transferred to work in the newly established 'Xinjiang Plantation and Construction Corps' (*Xinjiang shengchan jianshe bingtuan* 新疆生产建设兵团). It is said that out of 200,000 soldiers in the Xinjiang Military Region (*Xinjiang junqu* 新疆军区), 175,000 were incorporated into the Corps, along with their families. This decision was driven by a military-strategic consideration as Xinjiang borders the Soviet Union, as well as an economic opportunity to reclaim more land for farming. 'Reclamation and garrison' (*tunken shubian* 屯垦戍边) is thus at the core of the Corps' creation and its continued existence.

There were two additional major influxes of the Han population into Xinjiang. Between 1959 and 1961, the devastating consequences of the Great Leap Forward created a severe problem of famine. Tens of thousands of impoverished peasant families moved to east-



ern Xinjiang to avoid starvation. At the time, it was called *mang-liu* (盲流) or 'involuntary movement' of people. Within a few short years the Han population increased rapidly in eastern Xinjiang (Tian, Lin 1986). Then, with the beginning of the Cultural Revolution in the mid-1960s, the policy of sending a large number of urban educated youth to be "re-educated" in rural areas moved many Han youths to frontier regions, including Xinjiang. Between 1963 and 1966, Shanghai alone may have sent 80,000 to 90,000 youths to Xinjiang. However, most of these 'sent-down youths' returned to their home cities after the Cultural Revolution.

In the forty years from 1950s to the 1990s, there was mass migration of the Han to frontier regions. The most drastic change took place in Inner Mongolia, where the total percentage of the Mongol population dropped from 25% to 8%, while the Han population rose from 75% to 82% (Benson, Svanberg 1998). In Xinjiang, the percentage of all minority nationalities, including Uyghurs, Kazaks, Mongol, and Hui dropped from 90% to 60% and the Han population increased from 8% to 40% (Benson, Svanberg 1998). The changes in Tibet were not as drastic, probably due to its high plateau climate that was not suitable for the farming life of the Han. Until the early 1980s, the Han population in Tibet was essentially limited to party, government, and military personnel. After China shifted to an open and reformist policy in the 1980s, Tibet began to attract a larger number of Han immigrants who were involved in the development of tourism. However, the Han were basically concentrated in Lhasa and a few big cities in Tibet (Heberer 1989).

The ratio clearly indicates the Han nationality's growing presence in the minority regions, but it does not reveal the growth of minority populations. As explained earlier, the 'one child' policy successfully curtailed the growth of the majority Han population but was largely disregarded in minority regions. Xinjiang, for example, had a Han population numbering 5.13 million in 1978, while the Uyghur population was 5.55 million. In the population figure for Xinjiang in 2019, the Han population numbered 7.85 million while the Uyghur population had increased to 11.67 million.<sup>1</sup> With the rapid population increase of minority nationalities compounded by continued influxes of the Han population, this combination is likely to intensify the tension in the minority regions and set off crises. It will severely challenge Beijing's ability to continue to navigate in the very treacherous course; it may also provide a great opportunity for the regime to devise a more balanced policy to accommodate desires of all inhabitants.

---

**1** National Bureau of Statistics of China publishes the official census at <http://www.stats.gov.cn/english/Statisticaldata/CensusData/>. *Zhongguo minzu tongji nianjian* 中国民族统计年鉴 (Statistical Yearbook of Chinese Ethnic Groups) can be found at <http://www.tjcn.org>.

In reviewing the history of China's nationality policy under the PRC, we realise that the policy has been inconsistent, changing from time to time due to the political environment. During the first thirty years of the CCP's rule, the desire for national cohesion was the priority, followed by the aspiration of a social revolution. The control of the frontier regions was under the military, and the rule over local inhabitants high-handed. Beginning in the 1980s, as the country moved to its 'Reform and Opening-up' era, the nationality policy shifted away from the legacy of the Cultural Revolution and showed signs of being more balanced, as indicated by the 1982 Constitution reaffirming the principle of ethnic autonomy. There are signs that the relative 'liberal' nationality policy in the 1980s and 1990s is changing. However, this is a contemporary issue beyond the scope of this essay.

## 6 Conclusions

China became a truly multi-ethnic state under a centralised government during the Qing dynasty. The Manchus, a minority nationality ruling the Chinese majority, were conscientious of the nationality problem. They developed a nationality policy that was not based on the principle of equality, giving preferential treatment to Mongols and Tibetans while handling Muslims forcefully. But this was a practical policy, clearly designed to garner support, and prevent and suppress opposition. In practice, the Manchus would not hesitate to adjust their policy from one of conciliation to one of severe punishment. This policy ensured loyalty and obedience to the ruling élite and secured the dynasty's vast frontier territories for more than two centuries.

A fundamental weakness in this policy was its ultra-conservative aim of the maintenance of the status quo, with no desire to make changes to the system. It is questionable if such a policy could be maintained in the twentieth century, even if the Qing dynasty did not fall in 1911. This policy failed to recognise the more precipitate economic and social changes taking place in Mongolia and Tibet, as well as the increasing identity trend of Mongols and Tibetans in their own national consciousness.

The special favour accorded to Mongols and Tibetans by the Qing court was not offered to other ethnic minority people. In fact, the Qing nationality policy towards other ethnic minorities was exploitative and oppressive, resulting in severe dissatisfaction among those minority peoples. After the Qing power declined, these minority peoples often rebelled openly against the government. Such rebellions became a major source of political disturbance during the latter half of the Qing dynasty. Therefore, on the whole, it is difficult to consider the Qing nationality policy successful.

The fall of the Qing dynasty immediately caused political uncertainty in Mongolia and Tibet. The old loyalty and ties were broken, and the Mongol and Tibetan leaders soon declared their independence and separation from the newly established Republican government in China. The interference of foreign imperialist powers made the situation more complex, and the new central government was too weak to take back those territories by force. Eventually a compromise was reached for Mongolia and Tibet to loosely recognise China's suzerainty and each kept their own *de facto* independence.

After the founding of the Republican government, the political leaders embraced Sun Yat-sen's idea of the equality of the Five Nationalities. However, the central government did not include minority leaders in governance of the country, and the principle of setting up 'nationality self-government' remained a lip service. While Beiyang government was too weak and too involved in civil strife to give attention to nationality problems in the country, the Nanjing government did not earnestly promote the Principle of Nationalism that involved minority nationalities. Like the Beiyang government, the Nanjing regime did not have much time to develop its own nationality policy, and the outbreak of the war against Japan stalled the Nationalist nation-building effort in this respect.

Soon after the CCP came to power and established the PRC in 1949, it began to formulate a nationality policy on the foundation of the principle of minority self-governance. Rather quickly, the central government organised and sponsored groups of social scientists to conduct field investigations of the situation of ethnic minorities in the country. This project ultimately identified 56 nationalities.

The project [...] was neither a Communist-imposed scheme whose ethnological dimensions can be dismissed as pseudoscience, nor a purely social scientific endeavor that can be treated apart from the broader history of modern Chinese ethnopolitics. (Mullaney 2012)

At the same time, various autonomous administrative units were established. However, the implementation of this nationality policy often came into conflict with the highly centralised Party organisation. When such conflict happened, the Party authority made final determination. The state also began programmes for the training of minority cadres and officials. Similarly, the coexistence of Han officials often curtailed the power of minority cadres. The nationality policy was severely limited in its implementation.

Another serious problem in the nationality policy of the PRC was the shift from an early policy of seeking collaboration of traditional leaders in the minority regions to a 'revolutionary policy' of socialist construction. It caused a great deal of confusion for the people and cadres in the minority regions. Many minority cadres and

officials were placed in an uneasy position of whether to obey orders from the Party or retain a sense of loyalty to their own tradition in their own community.

One other practical problem in the nationality policy was Han migration to minority regions. Although such migration had happened in historical times, the massive number of Han migrants to frontier regions during the first two decades of CCP rule was significantly different. The migrants included military and Party personnel and members of farming families from overly populated areas not far from frontier regions. Later on, the political movement of sending down educated youth to rural areas also reached more remote frontier regions. After the 1980s, when the Party changed its policy to an emphasis on economic development, frontier minority regions attracted many Han people to invest and work in the tourist industry. Decades of Han migration to minority regions changed the population ratio and caused suspicion from the minorities. It also sowed seeds for racial conflict and raised serious doubt about the sincerity of the central government's attitude of respect to the minority peoples.

As this essay outlines, Chinese powers recognised the diversity of peoples among the country's population. The Qing rulers were the first to attempt formulating and implementing a nationality policy. Subsequent regimes developed respective policies based on the legacy of the Qing and other political frameworks. We have seen how the various governments, with different objectives, favoured or suppressed different ethnic populations accordingly. Today, the same opposing considerations for the Chinese government remain intact: the competing interests for central control and regional autonomy, and for political unity with equal respect for cultural diversity.

## Bibliography

- Bao Xiuping 包修平 (2020). "Zhongri zhanzheng guomin yu huimin waijiao" 中日战争与回国民国外交, 1937-1941 (War Against Japan and Diplomatic Relations with the Hui People, 1937-1941). Sawai Mitsuo 泽井充生 (ed.), *Riben huangminhua zhengce* 日本皇民化政策 (Policy of Japanisation). Tokyo: Capital University.
- Benson, L.; Svanberg, I. (1998). *China's Last Nomads: The History and Culture of China's Kazaks*. New York: M.E. Sharpe.
- Bovingdon, G. (2014). "Hu Wants Something New: Discourse and the Deep Structure of Minzu Policies in China". Williams, S.H. (ed.), *Social Difference and Constitutionalism in Pan-Asia*. Cambridge: Cambridge University Press, 165-92.
- Chen Bingyuan 陈秉渊 (1981). *Ma Bufang jiazu tongzhi Qinghai sishinian* 马步芳家族统治青海四十年 (Forty Years of the Ma Bufang Family Control of Qinghai). Qinghai: Qinghai renmin chubanshe.

- Chen Leqi 陈乐齐 (1989). "Woguo minzu guanxi riye gonggu he fazhan" 我国民族关系日益巩固和发展 (Increasing Consolidation and Development of Nationality Relations in Our Country). *Renmin Ribao* 人民日报海外版, 28 December.
- Chen Wenhong 陈文鸿 (1986). "Zhongguode minzu quyu zizhi zhengce" 中国的民族区域自治政策 (Nationality Regions' Autonomy Policy). *Zhongguode minzu quyu zizhi zhengce* 中国的民族区域自治政策 (Nationality Regions' Autonomy Policy). *Mingbao Monthly* 明报月刊, November 1968.
- Chen Youxi 陈又新 (1998). *Qingchao qianqi chuli yu xizang youguande minzu geli cuoshi* 清朝前期处理与西藏有关的民族隔离措施 (Early Qing's Regulations on Xizang's Nationality Separation). Taipei: Committee on Mongolia and Tibet.
- Fei Hsiao-tung 费孝通 (1978). "Ethnic Identification in China". *Social Sciences in China*.
- Ge Zhuang 葛壮 (2002). *Yisilan yu Zhongguo shehui* 伊斯兰与中国社会 (Islam and Chinese Society). Taipei: Dongda Books Company.
- Guo Tingyi 郭廷以 (1979). *Zhonghua minguo shishi rizhi* 中华民国史事日誌 (Historical Diary of the Republic of China). Taipei: Institute of Modern History, Academia Sinica.
- Guo Tingyi 郭廷以 (1980). *Jindai Zhongguo shigang* 近代中国史纲 (Modern China's History). Hong Kong: Chinese University Press.
- Hao Shiyuan 郝时远 (2004). *Zhongwen 'minzu' yici yuanliu kaobian* 中文'民族'一词源流考辨 (Examining Chinese Term *Minzu*'s Origins). Beijing: *Minzu yanjiu*. 民族研究 (Nationality Research) 6.
- Hao Shiyuan 郝时远 (2012). *Zhongguo minzu zhengcede hexin yuanze burong gaibian* 中国民族政策的核心原则不容改变 (The Core of Chinese Nationality Policy not Allowed to Change). Beijing: *Zhongguo minzubao*.
- Harrell, S. (ed.) (1995). *Cultural Encounters on China's Ethnic Frontiers*. Seattle: University of Washington Press.
- Heberer, T. (1989). *China and Its National Minorities: Autonomous or Assimilation?*. New York: M.E. Sharpe.
- Hu Hangang 胡鞍钢; Hu Lianhe 胡联合 (2012). "Dierdai minzu zhengce: cujin minzu jiaorong yiti he fanrong yiti" 第二代民族政策: 促进民族交融一体和繁荣一体 (Second Generation Nationality Policy: Promoting Nationality Fusion and Prosperity). *Xinjiang shifan daxue xuebao* 新疆师范大学学报, 5.
- Kaup, K.P. (2000). *Creating the Zhuang: Ethnic Politics in China*. Boulder: Lynne Rienner.
- Lai Cunli 赖存理 (1988). *Huizu shangyeshi* 回族商业史 (History of Commerce of the Hui Nationality). Beijing: New China Books.
- Leibold, J. (2004). "Positioning 'Minzu' Within Sun Yat-Sen's Discourse of *Minzuzhuyi*". *Journal of Asian History*, 38(2), 163-213.
- Li Xuan 励轩; Qian Zhengyu 钱争予 (s.d.). "Tujie Zhongguo wushiliuge minzu" 图解中国五十六个民族 (Visual illustrations of the fifty-six nationalities in China). *CNPPolitics* 政见. [http://cnpolitics.org/wp-content/uploads/2012/05/56Nations\\_Ver4.3.1.jpg](http://cnpolitics.org/wp-content/uploads/2012/05/56Nations_Ver4.3.1.jpg).
- Li Ziyuan 李资源 (1999). "Shaoshu minzu zai Wuhan kangzhan shiqide gongxian" 少数民族在武汉抗战时期的贡献 (Contributions by Nationality Minority During the War Against Japan in Wuhan). *Jinian Wuhan kangzhan liushi zhounian huiyi lunwenji* 纪念武汉抗战六十周年会议论文集 (Proceedings of the Sixtieth Anniversary of the War Against Japan in Wuhan). Wuhan: Hubei renmin chubanshe.

- Lin Enxian 林恩显 (1988). *Qingchao zai xinjiangde han-hui geli zhengce* 清朝在新疆的汉回隔离政策 (The Qing's Separation Policy Towards the Han and Hui Peoples). Taipei: Commercial Press.
- Ma Hongkui 马鸿逵 (1984). *Ma Shaoyun huiyilu* 马少云回忆录 (Memoir of Mao Shaoyun). Hong Kong: Wenyi shuwu.
- Ma Rong 马戎 (2004). *Lijie minzu guanxi xinsilu – shaoshu zuqun wentide 'qu zhengzhihua'* 理解民族关系新思路 – 少数民族问题的‘去政治化’ (New Thoughts on How to Understand Minzu Relations – ‘Depoliticising’ Ethnic Minority Issues). Beijing: Beijing daxue xuebao, 6.
- Ma Rong 马戎 (2013). “Dui dangdai minzu zhengcede fansi” 对当代中国民族政策的反思 (Reflections on the Current Nationality Policy in China). *Gongshi zaixian* 共识在线, 23.
- Mullaney, T. (2012). *Coming to Terms with the Nation: Ethnic Classification in Modern China*. Oakland: University of California Press.
- Rigger, S. (1995). “Vices of Manchu Identity, 1635-1935”. Harrell, S. (ed.), *Cultural Encounters on China's Ethnic Frontiers*. Seattle: University of Washington Press.
- Shi Lun 史伦 (1989). *Xibei Majia junfa shilue* 西北马家军阀史略 (Brief History of Warlord Ma in Northwest). Lanzhou: Gansu wenshi yanjiusuo.
- Tian Fang 田方; Lin Fatang 林发棠 (1986). *Zhongguo renkou qianyi* 中国人口迁移 (China's Demographic Movement). Beijing: Zhishi chubanshe.
- Xiao Yishang 萧一山 (1962). *Qingdai tongshi* 清代通史 (The General History of the Qing). Taipei: Commercial Press.
- Yang Jianxin 杨建新 (1988). *Zhongguo xibei shaoshu minzushi* 中国西北少数民族史 (Nationality History of Minority Groups in China's Northwest). Yinchun: Ningxia remin chubanshe.
- Yang Jingren 杨静仁 (1990). “Shehui zhuyi xiandaihua jianshe shiqi minzu gongzuode renwu” 社会主义现代化建设时期民族工作的任务 (Task of Nationality Work in the Period of Socialist Modernisation). *Xinshidai minzu gongzuowenxian xuanbian* 新时期民族工作文献选编 (Selected Works on Nationality Work During the New Era). Beijing: Zhongyang wenxian chubanshe.
- Yasui Sankichi 安井三吉 (1989). “Shaoshu minzu yu kangri zhanzheng” 少数民族与抗日战争 (Minority Nationalities and the War Against Japan). Ikeda Makoto 池田诚 (ed.), *Kangri zhanzheng yu Zhongguo minzhong* 抗日战争与中国民众 (The War Against Japan and the Chinese People). Beijing: Qiushi chubanshe.
- Zhang Zhongfu 张中复 (2001). *Qingdai xibei huimin shibian* 清代西北回民事变 (The Hui Incident in Northwest During the Qing). Taipei: Lianjing chubanshe.
- Zhao Yuntian 赵云田 (1986). “Qingchaode lifanyuan” 清朝的理藩院 (The Qing's Office of Frontiers). *People's Daily*, 15 November.
- Zhu Hongyuan 朱泓源 (1985). *Tongmenghuide geming lilun* 同盟会的革命理论 (The Revolutionary Theory of the Tongmenghui). Taipei: Institute of Modern History, Academia Sinica.

**The Historian's Gaze**

Essays on Modern and Contemporary China  
in Honour of Guido Samarani

edited by Laura De Giorgi and Sofia Graziani

# Sun Yat-sen: a Life Beyond Symbols. A Semiotic Approach to Modernity

Aglaia De Angeli

Queen's University Belfast, UK

**Abstract** Sun Yat-sen is the quintessential Chinese historical figure embodying modernity: a revolutionary representative of Chinese national identity still revered on both sides of the Taiwan Strait. This essay takes an interdisciplinary approach to Sun's emblems of modernity, drawing upon semiotics and the study of material culture. The symbols examined are: Sun's photographic portrait as Provisional President of the Republic of China; his photographic portrait as Director General of the National Railways; the suit which he created and which was given his name; and his mausoleum in Nanjing, which have all been deployed to perpetuate Sun Yat-sen's memory and appropriate it in support of later political agendas.

**Keywords** Sun Yat-sen. Modernity. Semiotic. Chinese identity. Politics mausoleum.

**Summary** 1 Introduction. – 2 Sun's Portrait and Official Photographs. – 3 Sun Zhongshan's Suit. – 4 Sun's Mausoleum. – 5 Semiotics: Sun's Communication Strategy and Chinese Modernisation. – 6 Conclusions.

## 1 Introduction

Sun Yat-sen<sup>1</sup> is the quintessential historical figure representing modernity in China.<sup>2</sup> He is the revolutionary archetype and the emblem of Chinese national identity. Sun embodies a modernity counterposed to the Confucian society governed by the ultra-conservative Qing court, whose power was limited to central and provincial institutions, and at the county level through the bureaucratic network. Sun's revolutionary programme succeeded in overthrowing this monarchical institution, but it did not achieve the distribution of power to the people through a form of democracy, as proposed in his political doctrine of "the three stages of the revolution" set out in the Three Principles of the People. The goal, according to Sun's Principles, was to free China - a "hypo-colony", in his own words - from foreign dominance, so that China could regain territorial integrity and the sovereignty of the people. Then, China would be a whole and free nation (Domes 1989). Sun's modernity, then, was Nationalist in the sense that it aimed to supplant both the foreign ruling dynasty and the imperial government, whilst remaining connected to the tradition of a Chinese government led by the Chinese people. Thus, as we will see in the discussion of the mausoleum below, there is no contradiction in talking about modernity whilst using symbols deriving from the Song and Ming dynasties, such as the proximity of Sun's mausoleum to the Ming tombs, or the choice of Nanjing as the capital of the newly established Republic of China. Imperial symbols such as these were appropriated to serve the purposes of Chinese cultural and political nationalism and modern state-building, and thus effectively contributed to shaping post-imperial Chinese identity.

This essay presents some preliminary research results on Sun's politics and legacy, examined through an interdisciplinary approach drawing upon semiotics and the study of material culture.

This essay discusses the use of symbols as signs of Chinese modernity. Referring to Ferdinand de Saussure's semiotics, I scrutinise three symbols associated with Sun Yat-sen: his portraits and official

**1** For in-depth overviews of Sun's life and political career, see Bergère 1998; Gordon 2010. On Sun's revolutionary activities and the revolution, see Schiffrin 1970; Wong 1986; Lum, Lum 1999; Lee, Lee 2015; Anderson 2021. On Sun's political views and experience, see Wells 2001; Tjio 2017; Cheng 1989; and on the relationship with the Soong family, see Hahn 1941.

**2** Discourses of modernisation, according to Williams ([1976] 1988, 209), "have become increasingly common in C20 argument. In relations to institutions or industry they are normally used to indicate something unquestionably favourable or desirable". For an in-depth view of modernity and its consequences from cultural and epistemological viewpoints, see Giddens 1990, and for an overview of modernity in the Chinese context see Duara 1995; Yeh 2000; Zarrow 2006; Sun 2021.



photographs; Sun's suit, known to the West as the 'Mao jacket'; and Sun's mausoleum in Nanjing.<sup>3</sup>

The portrait and the suit are symbols that Sun Yat-sen himself chose. Consequently, his agency permeates them and they remain forms of self-representation which have long survived his death; while the mausoleum was planned and built by others to venerate his political legacy. In the mausoleum, Sun's embalmed body and persona is transformed into a symbol. Because this is a posthumous act, Sun's own agency and self-representation are absent from the mausoleum, but his physical presence invests it with the power of a *lieu de mémoire* (Cadot 2010).

Saussurean semiotics provides the intellectual framework within which the aforementioned signs are interpreted in order to understand the ideas of modernity that Sun sought to transmit to the Chinese people, as well as their legacy and contemporary reinterpretation.

The Swiss linguist Ferdinand de Saussure, considered, alongside Charles Sanders Peirce, a founder of semiotics,<sup>4</sup> imagined a science for the study of signs "at the heart of the society": a science focussed on the relationship between various systems of codified symbols combining expressive form with meaningful content. Importantly, Saussure considered the relation between expressive form and meaningful content to be determined by a "relative motivation" limiting arbitrariness by some sort of rational connection with the society to which the symbols belonged (Parmentier 2015, 3-4). The symbols considered in this research are set in the China of the 1910s and 1920s, when the country was undergoing profound processes of modernisation. As Cerulo (1993, 244) noted in her study of symbols and the world-system, experiences of modernisation and position within the world-system "influence the structure of the symbols by which national leaders convey their nation's identity". Therefore, to understand the relationship between the adoption of symbols and the modernisation process, we need to examine the communication strategy that functions as a "limit to arbitrariness" between symbols and society as conceptualised by Saussure. To comprehend this "relative motivation", I use both semantic and syntactic analysis of symbols as proposed by Cerulo (1993, 246), who defines semantic analysis as a

<sup>3</sup> An extensive study of Sun's mausoleum and Republican ritual symbolism was published by Rudolf Wagner (2011). The present study builds upon Wagner's work but is distinct from it, because the focus for Wagner was the ritual governance associated with the death and enshrinement of Sun in the mausoleum, while this essay focuses on the semiotic analysis of symbols associated with Sun as representations of Chinese modernity, and the mausoleum is just one of the three examined.

<sup>4</sup> For the history of semiotics see Nöth 1995; Boklund-Lagopoulou, Lagopoulos 2021; and on Charles Sanders Peirce, the other founding figure (who never met Saussure), see Thellefsen, Sørensen 2014.

process that “isolates the symbol’s elements and focuses on the meaning of each of those elements”, and syntactic analysis as the process that “examines the meaning conveyed by a symbol’s structure – its design or configuration and the relationship between its parts”.

To fully understand the symbols associated with Sun and modern China, this essay presents a description of Sun’s symbols and their historical contextualisation. Sun’s portraits, Sun’s suit, and Sun’s mausoleum will be scrutinised according to the semantic and semiotic analysis in order to reveal their communication strategy and “relative motivation”, enabling assessment of the relation between Sun’s symbols and Chinese society, and the ways this relation impacted or reflected the modernisation process in China. Finally, I distinguish the signs according to “Peirce’s most used [...] distinction between sign relations based on formal resemblance or ‘icons’, relations based on physical contiguity or ‘indexes’, and relations based on arbitrary convention or ‘symbols’” (Parmentier 2015, 6).

Analysis of the ways these symbols and their indexical, iconic, and symbolic status were used to produce meanings reveals both Sun’s strategic communication with the Chinese people about the modernisation of their country; and how Sun himself became the symbol of an era associated with the beginnings of Chinese modernity.

## 2 Sun’s Portrait and Official Photographs

The revolution had been initiated in Wuchang on 10 October 1911, by members of the United League in alliance with rebellious elements of the military. The Wuchang uprising expanded to neighbouring provinces where insubordinate military commanders offered no resistance and by the end of 1911, the Qing dynasty had collapsed. In three months, a provisional government was established. Sun Yat-sen was elected Provisional President and when the First Year of the Republic was proclaimed, on 1 January 1912, Sun assumed office.

On that day, a photograph of him in his role was taken portraying the top half of his body, slightly in profile. Sun was wearing a military uniform with a fob watch in the left pocket. His hair was short and left parting, his moustache also short, but bristly. Sun’s glance was earnest but instilling confidence. This portrait presents Sun as a military leader and a revolutionary [fig. 1].

His modern military uniform aligned him with the revolution’s principles and distinguished him from the old Manchu dynastic regime. The visual rupture between this photograph and portrayals of imperial rulers in traditional robes is sharp. On the many official occasions where Sun appeared in his role as Provisional President, he dressed in a Western three-piece suit – jacket, waistcoat, and creased trousers – with a tie, and sometimes a hat. This form of dress maintained



**Figure 1** Sun Yat-sen's portrait as Provisional President of the Republic of China. © McCormick 1913, 366

the association of Western dress with modernity and presented a visual contrast with the traditional robes of Manchu officials, but exchanged the military uniform of a revolutionary for the civilian attire of an established political leader. The other occasions on which Sun was photographed dressed in uniform, as for the official portrait, were in December 1911 on his journey from Shanghai to Nanjing to be nominated President, accompanied by Hu Hanmin, and during his participation in the visit of civil and military officials to the Ming imperial tomb in Nanjing on 16 February 1912. On the second occasion, he had already stepped down from the role of Provisional President of the Republic of China. In fact, six weeks after his provisional nomination, on 12 February, the Qing government abdicated and formally recognised the Republic, upon which, to avoid bloodshed, Sun Yat-sen resigned his position in favour of Yuan Shikai, who was trusted by both revolutionaries and the monarchy, having acted as a liaison between them.

Soon after stepping down as President, Sun toured the country to examine the actual conditions of the people, and subsequently advocated for the development of education and practical knowledge to modernise the nation. Sun was adamant that communications, particularly the railway network, were the backbone of the modernisation process, so it was significant that in August 1912, he was appointed Director General of the National Railways. Sun made tours of inspection of the various railways already built, whilst planning the construction of a further 200,000 miles of railway line over the following ten years. To study developments in railway construction, Sun visited Japan in February 1913 (Edmonds 1987).

Sun's second photograph portrays him on board of a train in Tianjin in August 1912, the month that he was appointed Director General of the National Railways [fig. 2].



**Figure 2** Sun Yat-sen as Director-General of the National Railways, 1912. Source: Chinese Cultural Association, Faure C.M., and F.I.L. (1965). *A Pictorial Biography of Dr. Sun Yat-sen*. Hong Kong: Ertiantang yinwu youxian gongsi

This photo symbolises the modernisation process which was central to Sun's revolutionary movement. Since the formation of his first political association, the Revive China Society (Xing Zhong Hui 興中會), Sun had wanted China to modernise at the same pace as Japan, an Asian country he saw as an inspiration, to be able to deal with Western powers from a basis of technological and military equality.

Whilst Sun toured China in his role of Director General of the National Railways, he dressed in civilian clothes, the three-piece suits that he wore on other occasions. In the photograph taken during his tours of inspection of the railway system, Sun appears as a modern

official, dressed in Western style to represent progress and rupture with the conservatism of the dynastic past.

According to Peirce's scheme, Sun's portrait as Provisional President of the Republic of China - a solo image - may be seen as an iconic sign, its meaning based on the formal resemblance between Sun and his portrait. From a Saussurean perspective, the meaningful content of Sun's portrait lies in its visual expression of the values of Sun's revolutionary cause. At the same time, Sun's photographs as Director General of the National Railway, taken on board a train carriage whilst inspecting China's railway network in preparation for future development, are indexical signs, drawing attention to Sun's practical involvement in the modernisation process. Therefore, Sun's official portrait in uniform represents the success of the revolution, whilst his portrayal on a train in a civilian suit represents the modernisation process which followed.<sup>5</sup>

### 3 Sun Zhongshan's Suit

The second symbol through which Sun is remembered today is the 'Sun Yat-sen suit' or *Zhongshan Zhuang* (中山装), known in the West as the 'Mao jacket' or 'Mao suit'.<sup>6</sup> Lu Hanchao (1999, 253-4) notes that the origins of the idea for the suit are not known, but that Sun acquired his in 1920 from the Rongchangxiang Woollen Fabrics and Western Suits shop in Nanjing Road, Shanghai, where he either bought a new suit or took one in a different style for alteration. The result was a civilian version of a military uniform. Sun's adoption of the suit during his time as Provisional President symbolised a rejection of both the traditional robes of the Qing bureaucracy and the civilian suits worn by Western political leaders. Rather, the suit presented an image which was both distinctively modern and distinctively Chinese. Consequently, the suit became the signature dress of the Nationalist revolution. Finnane (2008, 183) explains its symbolism:

<sup>5</sup> Lu Hanchao (2010, 7) explains that a limited amount of visual material survived from the time of the Xinhai Revolution: "Because war correspondence was not an established profession and the camera was a rare apparatus in China at the time, very few photographs of the revolution were taken". Therefore, Lu points to three contemporary publications as repositories for the photographs of the Chinese revolution that still circulate today: Edwin J. Dingle's *China's Revolution, 1911 to 1912*; Frederick McCormick's *The Flowery Republic*, published in 1913; and the collection of Francis Eugene Stafford, available at the Hoover Institution website: <https://www.hoover.org/news/francis-eugene-stafford-photograph-collection>.

<sup>6</sup> Cf. <https://fashion.sohu.com/20180102/n527002149.shtml>.

The jacket was close-fitting and buttoned down the centre, with square pockets at breast and waist, and was worn over trousers cut in Western style. In time, its unremarkable stylistic features were invested with deep political significance: the three buttons on each sleeve cuff stood for the Three Principles of the People, the four pockets for four Nationalist principles and the five front buttons for the five branches of the Nationalist government.

During the Republican period, the Sun Yat-sen suit became popular among students (Lu 1999, 254), and schools were prompted to adopt it as a school uniform as its central buttons did not distinguish between “left and right sides”, but it also had the advantage of being “economical since it used less fabric than the long gown, healthy because, unlike the long gown, [it is] beautiful, and will inculcate a martial spirit” (Harrison 2000, 176). The suit also became popular among revolutionaries in Canton in the 1920s (Finnane 2008, 183). Harrison explains that claims that the suit encouraged martial spirit made by those advertising school uniforms appealed to Nationalist supporters and became associated with revolutionary commitment. To wear the suit was to embody revolutionary spirit, to materially mark oneself as a moderniser committed to the revolutionary agenda.

After Sun’s death in 1925, the Sun Yat-sen suit remained fashionable and became increasingly popular even in rural areas, where it was seen as a symbol of a patriotic spirit, thanks to the Nationalist revolution. When the Northern Expedition ended successfully, the fashion spread from the South to the North of China, and men who continued to wear traditional gowns were seen as “old school, old regime”. The popularity of the Sun Yat-sen suit continued even after the end of the civil war of 1946-49 and the establishment of the People’s Republic of China. A photograph of Mao Zedong and Chiang Kai-shek taken in Chongqing during the negotiations following the end of the anti-Japanese war suggests a case of ‘separation at birth’ which was not too far from the fact in political terms. Their suits were virtually identical: well cut, of good material, and faithful to the style established by Sun Yat-sen (Finnane 2008, 182-4).

This image is emblematic. In fact, both Chiang and Mao, representatives of the Nationalist and Communist parties of China respectively, wore the Sun Yat-sen suit, demonstrating their loyalty to his political doctrine, the Three Principles of the People. Wearing Sun’s suit was a way in which each leader sought to state publicly that they were the legitimate heir of Sun Yat-sen, that their political doctrine was faithful to Sun’s political vision [fig. 3].



**Figure 3** Chiang Kaishek (left) and Mao Zedong (right) wearing the Sun Yat-sen suit in Chongqing, 1945. [https://www.sohu.com/a/410130947\\_523187](https://www.sohu.com/a/410130947_523187)

Sun's suit is a symbolic sign, because according to Peirce's scheme, its relation to Sun Yat-sen is an arbitrary convention based on the Chinese agreeing on the association of the Sun's suit design with Sun's doctrine, Nationalist ideology, and government structure. In Saussure's terms, Sun's suit – the expressive form – is associated with the meaningful content embodied by the revolutionary cause and ideology: the three buttons on the sleeve cuff representing the Three Principles of the People; the four pockets representing the four political and civil rights of the people (i.e. the power of election, the power of recall, the power of initiative, and the power of referendum) which aimed to balance power between the people and the government; and the five front buttons standing for the five branch-

es of the Nationalist government, the Executive Yuan, the Legislative Yuan, the Judicial Yuan, the Examination Yuan, and the Censorate Yuan.

Furthermore, according to Cerulo's theory, the symbolic structure of Sun's suit is a sample of complex or embellished syntactic structure, because the rich symbolism communicates a complex new political ideology and system. Sun's suit structure refers to and communicates with the heterogeneous and factionalised society that characterised China in the 1920s and 1930s. The complex symbols of the jacket - the three buttons on each sleeve cuff, the four pockets, and the five front buttons embody an embellished communication strategy requiring "universal attention from a factionalized audience" (Cerulo 1993, 245). The communication strategy adopts "a symbol structure that is variable, dynamic, and able to convey maximum amounts of information" (250), in this case a single garment represents the full scale of value of the Nationalist Party and its governmental apparatus.

#### 4 Sun's Mausoleum

The death of Sun Yat-sen was a political event of national importance. A few months before his death, in November 1924, Sun issued a *Manifesto on Going North*, in which he reaffirmed the Three Principles of the People as the political path towards a reunified China and the achievement of modernisation. The manifesto, launched during his last battle, was transformed from a political programme to a political will after his death in Beijing on 12 March 1925.<sup>7</sup>

Two funerals were held for Sun in Beijing on 19 March: one was a private Christian ceremony according to his and his family's wishes, whilst the second was secular and public. The private funeral was a Baptist service held in the Great Hall of the Beijing Union Medical College. Immediately after the ceremony, Sun's coffin was moved to the park adjacent to the imperial palace buildings. Those drawing and escorting the hearse represented other groups symbolically claiming Sun as their forefather - his Guomindang (GMD) followers, dressed in formal gowns and black satin jackets, his student admirers carrying banners, and his Russian supporters. The coffin was draped with the GMD flag. After three weeks, during which the coffin lay in state while the public filed past in homage, it was moved to the Temple of Azure Clouds in the Western Hills, Beijing, before being moved to Nanjing for burial, in accordance with his expressed wish. The burial in Nanjing was a national event, in

<sup>7</sup> For an in-depth study of Sun's doctrine, see Cheng 1989.



which Sun's coffin was entombed in the mausoleum especially built for the 'Father of the Nation' under the aegis of the Nationalist Party, which was creating a cult of personality around their deceased leader (Bergère 1998, 407-8).

On 27 May 1929, the final journey of Sun's coffin from Beijing to Nanjing began.<sup>8</sup> The funeral procession, composed of three trains, made several stops along the way to allow the nation to pay tribute to Sun Yat-sen, and on 1 June 1929, the coffin of the late President was transferred to the Mausoleum of the Purple Mountains, in the neighbourhood of Nanjing (*North China Herald* 1929; *The China Press* 1929). During the national funeral led by Chiang Kai-shek and the principal Nationalist leaders, accompanied by an army escort, punctuated by the sound of cannons and attended by the diplomatic corps and thousands of ordinary citizens, Sun Yat-sen was interred in his last resting place (Howard 1929). The monumental character of his tomb, fronted by a huge flight of steps, the beauty of the surrounding wooded hills, and the proximity of the burial mounds of the ancient Ming emperors, to whose shades Sun Yat-sen had prayed at the founding of the Republic in 1912, all combined to enhance the solemnity of the setting and to encourage reverence (Lai 2005) [fig. 4].

The mausoleum design was explained by the *North China Herald* on 26 September 1925:

The winning design is of the Sung dynasty style, which from above formed the shape of a bell. At the entrance is a gate after the Ming style, and eight flights of steps and causeways lead from the entrance, the elevation of which will be about 180 feet. At the top of the steps is the memorial hall, after which one enters a second hall, where the tablets are to be erected. Behind the memorial hall will be found the tomb, an open space, where upon looking down, the coffin will be seen. The interior is strictly in accordance with Chinese style, the regular columns standing from floor to roof, these beams being of fine marble and granite. The roof will be of bronze.<sup>9</sup>

<sup>8</sup> A detailed account on the funeral procession, regulation, timing etc. was reported by Wagner (2011, 259-63).

<sup>9</sup> The same text appeared in an article, published on 3 October 1925 in *The China Weekly Review*, entitled "Prize Winning Design of Mausoleum for Body of Dr. Sun Yat-sen Is Won by Shanghai Architect" (*The China Weekly Review* 1925). Finally, the roof was not built in bronze, as stated by the press, or in copper, as designed by the architect, but in blue tiles to limit material costs (Wagner 2011, 248).

# 中山陵平面图

Sun Yat-sen Mausoleum

Plane figure

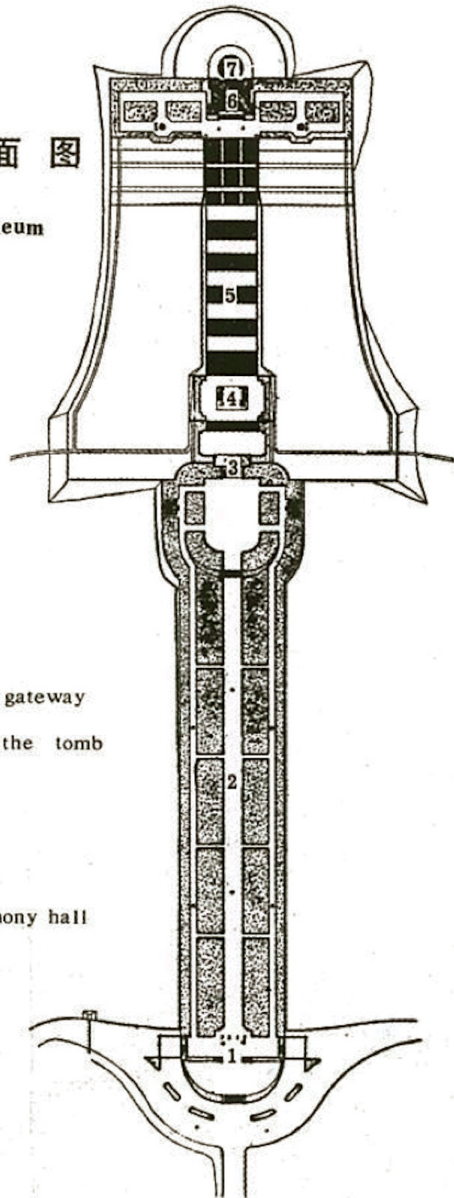

- 1 石牌坊 Stone memorial gateway
- 2 墓道 Path leading to the tomb
- 3 陵门 Mausoleum gate
- 4 碑亭 Tablet pavilion
- 5 石阶 Stone steps
- 6 祭堂 Memorial ceremony hall
- 7 墓室 Coffin chamber

Figure 4 Plan of the Sun Yat-sen Mausoleum and Park, Nanjing. Lü Yanzhi (1925). *Yao Qian and Gu Bing*, Sun Yat-sen Mausoleum, 80, quoted in Wagner 2017

According to Lai Delin, “the mausoleum should express a Chinese identity in addition to permanence and public character, two characteristics that were associated with architecture of the West and thus stood for modernity” (2005, 25).<sup>10</sup> The character of Sun Yat-sen’s distinctive revolutionary politics, which aimed to preserve Chinese identity by the appropriation of Western knowledge, had to be displayed by a monument aspiring to an international culture: a monument which broke with the past in its form and materiality. The shape of the *enceinte* walls was designed to form the silhouette of a bell, visible only from above, which was symbolically associated with the awakening of China. But despite the desired rupture with the imperial past, the mausoleum still used some of the conceptual framework from which it sought to break. In fact, the choice of the location was made based on geomancy: facing south like any imperial building (Wagner 2011, 236, 239). Nevertheless, the choice – made by Sun himself – to be buried next to the Ming tomb in Nanjing was a sign of rupture with Qing rule and at the same time, a reconnection with the Han ruling tradition.

As explained in the introduction, these elements of tradition are understood as forms of Chinese cultural nationalism legitimating the revolutionary act represented by the figure of Sun Yat-sen. They interpret the Xinhai Revolution and the establishment of the new Republic as restoring to the Chinese people the power to rule the Chinese nation, in the form of the new nation-state. The modernity symbolised by the mausoleum, then, is embedded in a rupture with the imperial past in general, which opens a path to break the shackles of foreign imperialism. Moreover, commentary on the links with the Song and Ming traditions in the contemporary press can be seen as references to a time of national unity and Han leadership of the Chinese nation (*The China Weekly Review* 1925).

Wydra (2012) has argued, in the Soviet context, that to understand symbolisation as rites of passage and constructions of origins and ends, we must understand the creativity of political symbolism. In the process of constructing modern Chinese nationhood and identity, Sun’s mausoleum is the epitome of such creativity. In the mausoleum we find the architectural representation of a changing Chinese ideology which nevertheless derives much of its legitimacy from the past. The iconography and architecture reveal signs of authority (Shirvani 2018) and transition from the past to modernity: thus the past is an essential element of the modernising process.

The symbolism of Sun’s mausoleum is complex and multi-layered. In this analysis, I distinguish between the mausoleum as an edifice

---

**10** On how the committee designed the competition, made the selection, and scrutinised the ways in which the proposed projects for the mausoleum embedded Sun’s political doctrine in the final planning, see Lai 2005, 24-38.

and the mausoleum as Sun's burial place. The mausoleum as an edifice was built in an area adjacent to, but at a higher altitude than, the Ming mausoleum on the Purple Hills of Nanjing. The choice of location may be seen as an indexical sign pointing to the legitimacy of Sun Yat-sen as ruler of China. The design and outline of the mausoleum, with its three ramps of stairs symbolising the Three Principles of the People and the *enceinte* in a bell shape representing the awakening of China, have a symbolic status. As Sun's burial place, the mausoleum communicates many additional semiotic meanings: first, Sun's sculptured figure lying in state on the tomb lid is clearly an iconic sign which transmits meaning through the resemblance between the sculpture and Sun.<sup>11</sup> Secondly, regulations since Sun's interment have prevented the construction of other tombs nearby, protecting the sacredness of the place, and highlighting again the indexical character of the tomb's proximity to the burial place of the Ming; and finally, the funeral procession for the transfer of Sun's body from Beijing to Nanjing in 1929 assumed a symbolic status, the train journey demonstrating the modernisation that Sun had initiated and the stops along the way allowing the Chinese to pay homage to the 'Father of the Nation' were a display of the national unity achieved thanks to the success of the Northern Expedition led by Chiang Kai-shek, but planned by the late Sun Yat-sen. Sun's mausoleum remains an important symbol of Chinese national unity: whenever representatives of the PRC and Taiwan governments meet officially, they begin proceedings by a joint visit to Sun's tomb.

Finally, the mausoleum is also a symbolic sign transmitting Sun's legacy to future generations, because it honours his memory and remains a place of visitation for those still wishing to offer their respect to Sun.

## 5 Semiotics: Sun's Communication Strategy and Chinese Modernisation

Hitherto, the essay has focussed individually on the semiotic analysis of Sun's portrait, Sun's suit, and Sun's mausoleum. Here, I focus on the syntactic analysis of Sun's symbols to understand how Sun and his followers used them to legitimate his formal authority, and how his supporters used them after his death. As Cerulo explains (1993, 244-5, 248-9), the syntactic structure of a symbol consists of the relation between each symbol's parts and represents a communication

<sup>11</sup> Sun's tomb had been originally planned to be like Lenin's, a casket of silver with a crystal lid, but the one sent by the USSR was not air-tight and moreover, was made of tin with a glass lid. The solution was to substitute it with a stone sarcophagus surmounted by a sculpted figure of Sun (Wagner 2011, 235).

strategy. Therefore, the selection of a symbol, which conveys the national identity, can be scrutinised against the process of modernisation and the position of the country within the world-system. Since both modernisation and membership in the world-system have consequences for cultural and economic development, and the process of political modernisation is vital to a country's development, we should ask how the modernisation and location within the world-system affect the symbol's syntactic structure.

As the communication strategy aims to convey national identity, Cerulo explains (1993, 244) that there are many variations to be taken into account, from those with a minimal impact, such as national colonial influence, geographical position and creative style of the symbol according to the period of adoption, to those with a higher impact, such as wars, revolutions, independence movements or changes in forms of government, to those of the highest impact such as the modernisation process and position in the world-system which significantly affect the economic development of a country.

On the basis that the adoption of a symbol and its inherent communication strategy serves as a tool of legitimacy and conveys national identity, we may conclude that only Sun's portrait adopted a basic syntactic structure, while Sun's suit and the mausoleum adopted an embellished syntactic structure. In fact, Sun's photograph follows the most common standard for a portrait of an institutional figure, a half-bust portrait from the front, dressed in a manner denoting his role as the new Republican President, a revolutionary and a political leader. It fits perfectly among portraits of other nations' leaders and serves as a national symbol of modern China in a well regulated area. Sun's portrait as the successful leader of the revolution that brought down the Chinese empire has a basic syntactic structure, which corresponds to a high level of internal command, as Sun assumed the role of Provisional President of the Republic of China. It stands as symbol of the political modernisation process that consolidated under the leadership of a single, centrally organised government led by Sun.

Sun's suit, on the other hand, has a complex syntactic structure with the buttons on the cuffs and on the front, as well as the front pockets, each making specific references to elements of Nationalist ideology and governance. The same is true of the mausoleum with its ramps of stairs, *enceinte* walls, decorative elements, sculptures etc. The embellished syntax of the symbols is a demanding communication strategy (Cerulo 1993, 245, 265-6), which aims to include into its structure as many elements or elaborations as necessary and represents the comparatively low level of domestic control commonly experienced by national leaders of "semi-peripheral nations", who uses "information-laden representations of national identity [...] to compensate for the weak implantation of power" (251). Cerulo suggests that the embellished syntactic structure of "symbols is adopt-

ed in heterogenous or factionalized social settings" (250) such as was China in the Republican period.

Following this semiotic analysis, both semantic and syntactic, we can claim that all symbols associated with Sun represent steps towards modernisation in China. Sun's portrait, with its basic symbolic syntax, communicates Sun's impact as a revolutionary leader on the political modernisation. Sun's suit and mausoleum, conversely, with their complex symbolic syntaxes, communicate the imprint that they wish to achieve on modernisation processes within China.

So far, we have approached these signs largely from the perspectives of those creating them. Their meanings, however, also depend upon the ways that they are received by their audience. Since their dissemination, Sun's symbols have been widely accepted as emblems of Chinese modernity within China. Foreign audiences have responded differently, however, either showing little interest, perhaps because they were not the targets of the communication strategy, as in the case of Sun's suit, or assuming a questioning stance, as in the case of Sun's mausoleum. This discrepancy between Chinese and foreign view offers an opportunity to assess the communication strategy in relation to the world-system.

The communication strategy of indexing the greatness of Sun Yat-sen as a symbol of Chinese modernity appears to have been highly effective in regard to Chinese people, whether in the People's Republic of China or Taiwan. A letter to the editor of *The China Weekly Review* entitled "An Objection to Views, on the Late Dr. Sun Yat-Sen (*The China Weekly Review* 1929) suggests that it was less effective in relations to other audiences. The letter-writer called on the editor to account for his decision to publish two supposedly "very ill written articles" by foreigners, "The Sun Yat-sen that China Worships" by Upton Close (1929), and "Why Sun Yat-Sen Rules Even in Death" by Count Carlo Sforza (1929). According to the complainant, the articles were "misleading and the content but full of cynicism". The writer went on to assert that the articles "injure the life and work of a really great man, at least in the history of 400,000,000 people, and their unjustifiable cynicism can only reflect upon their honor and reputation". The complaint to the editor highlights a discrepancy between national and international perceptions of Sun Yat-sen after his death. Whilst the embellished syntactic structure of the communication strategy adopted for Sun's burial ceremony and the engraving of his casket in the mausoleum appeared to be effective in establishing his greatness for Chinese, this was not the case with foreigners. The 'lionisation' of Sun did not lead to China being instated among the core nations of the world-system as Chinese modernisers had hoped, yet it disclosed the rupture with the past and an ongoing modernisation process that was recognised abroad but was considered embryonic and far from fully accomplished.

## 6 Conclusions

From the Xinhai Revolution onward, Sun Yat-sen assumed the role of unifier of the Chinese nation. His death made him part of its 'mythology'. Both Nationalist and Communist parties "made equal use of Sun Yat-sen, presenting him as a symbol of revolution, national emancipation, modernism, and socialism. [...] The facts were adapted to the demands of ideology and propaganda. And when, as Lenin had put it 'those facts proved too intractable, they were simply swept out of sight'" (Bergère 1998, 408).

The three emblems of Sun's legacy presented above all refer to the modern Chinese nation. First, Sun's photographic portrait as the first Provisional President of the Republic of China stands for the success of the Republican cause, while Sun's portrayal in his role as Director General of the National Railways is a symbol of his political aspiration to modernise China. These two photographs may be seen as icons, in that they represent Sun through resemblance to his appearance.

Secondly, the suit style that Sun created and that was given his name is a symbol of his power and was appropriated by those seeking to legitimate their own political positions by claiming his legacy. This was true of both Chiang Kai-shek and Mao Zedong in the 1940s, but in more recent times we have also seen Hu Jintao and Xi Jinping wearing it on the national day. In these contexts, the suit can be seen as an indexical sign pointing directly to Sun Yat-sen.

Finally, the mausoleum represents Sun's legacy to the Chinese people, and shows how in the early years of the Republic, architects sought to express the new Republican ideals, support the cause of modernisation, and represent a new Chinese identity in an international arena. The mausoleum is a multi-layered symbol which associates Sun Yat-sen with the modern Chinese nation he sought to create.

We may conclude that all three forms of sign identified by Peirce, icon, index, and symbol, have been deployed to memorialise Sun Yat-sen and harness his memory to various political agendas in China after his death.

## Bibliography

- Anderson, P. (2021). *Sun Yat-sen, Robert Wilcox and Their Failed Revolutions, Honolulu and Canton 1895: Dynamite on the Tropic of Cancer*. New York: Routledge.
- Bergère, M.-C. (1998). *Sun Yat-Sen*. Transl. by J. Lloyd. Stanford: Stanford University Press.
- Boklund-Lagopoulou, K.; Lagopoulos, A.P. (2021). *Theory and Methodology of Semiotics: The Tradition of Ferdinand de Saussure*. Berlin: De Gruyter.
- Bouissac, P. (2010). *Saussure: A Guide for the Perplexed*. London; New York: Continuum.
- Brophy, D. (2012). "Five Races, One Parliament? Xinhai in Xinjiang and the Problem of Minority Representation in the Chinese Republic". *Inner Asia*, 14(2), 343-463.
- Cadot, C. (2010). "Can Museums Help Build a European Memory? The Example of the 'Musée de l'Europe' in Brussels in the Light of 'New World' Museums' Experience". *International Journal of Politics, Culture, and Society*, 23(2/3), 127-36.
- Cerulo, K.A. (1993). "Symbols and the World System: National Anthems and Flags". *Sociological Forum*, 8(2), 243-71. <https://www.jstor.org/stable/684637>.
- Cheng, C. (ed.) (1989). *Sun Yat-Sen's Doctrine in the Modern World*. New York: Taylor & Francis Group.
- The China Press* (1929). "Remains of Sun Yat-Sen to Start Journey South from Peiping on May 27". *The China Press*, 25 May.
- The China Weekly Review* (1925). "Prize Winning Design of Mausoleum for Body of Dr. Sun Yat-Sen Is Won by Shanghai Architect". *The China Weekly Review*, 3 October.
- The China Weekly Review* (1929). "An Objection to Views, on the Late Dr. Sun Yat-Sen". *The China Weekly Review*, 1 June.
- Chinese Cultural Association (1965). *A Pictorial Biography of Dr. Sun Yat-Sen*. Hong Kong: Ertiantang yinwu youxian gongsi.
- Close, U. (1929). "The Sun Yat-sen that China Worships". *The China Weekly Review*, 25 May.
- Dingle, E.J. (1912). *China's Revolution, 1911 to 1912: A Historical and Political Record of the Civil War*. London: T. Fisher Unwin.
- Domes, J. (1989). "China's Modernization and Doctrine of Democracy". Cheng, C. et al. (eds), *Sun Yat-sen's Doctrine in the Modern World*. Boulder: Westview, 201-24.
- Duara, P. (1995). *Rescuing History from the Nation: Questioning Narratives of Modern China*. Chicago: University of Chicago Press.
- Edmonds, R.L. (1987). "The Legacy of Sun Yat-Sen's Railway Plans". *The China Quarterly*, 111, 421-43.
- Finnane, A. (2008). *Changing Clothes in China: Fashion, History, Nation*. New York: Columbia University Press.
- Giddens, A. (1990). *The Consequences of Modernity*. Stanford: Stanford University Press.
- Gordon, D.B. (2010). *Sun Yat-sen: Seeking a Newer China*. Upper Saddle River: Prentice Hall.
- Hahn, E. (1941). *The Soong Sisters*. New York: Doubleday, Doran & Co.
- Harrison, H. (2000). *The Making of the Republican Citizen: Political Ceremonies and Symbols in China 1911-1929*. Oxford: Oxford University Press.



- Howard, H.P. (1929). "China Pays Homage to Sun Yat-Sen in Great Burial Ceremony". *North China Herald*, 8 June.
- Lai, D. (2005). "Searching for a Modern Chinese Monument: The Design of the Sun Yat-Sen Mausoleum in Nanjing". *Journal of the Society of Architectural Historians*, 64(1), 22-55. <https://doi.org/10.2307/25068123>.
- Lee, L.; Lee, H. (eds) (2015). *Sun Yat-Sen, Nanyang and the 1911 Revolution*. Singapore: Institute of Southeast Asian Studies.
- Lu, H. (1999). *Beyond the Neon Lights: Everyday Shanghai in the Early Twentieth Century*. Stanford: University of California Press.
- Lu, H. (2010). *The Birth of a Republic: Francis Stafford's Photographs of China's 1911 Revolution and Beyond*. Washington: University of Washington Press.
- Lum, Y.M.; Lum, R.M.K. (1999). *Sun Yat-Sen in Hawaii: Activities and Supporters*. Honolulu: Hawaii Chinese History Center. [http://sunYat-senhawaii.org/wp-content/uploads/2017/11/Ebook\\_Sun\\_Yat\\_sen\\_English-ss.pdf](http://sunYat-senhawaii.org/wp-content/uploads/2017/11/Ebook_Sun_Yat_sen_English-ss.pdf).
- McCormick, F. (1913). *The Flowery Republic*. London: John Murray.
- North China Herald* (1926). "The Mausoleum for Dr. Sun Yat-Sen: Designs Adjudicated Upon: Prize of \$2,500 Won by Local Man". *North China Herald*, 26 September.
- North China Herald* (1929). "Remains of Dr. Sun Yat-Sen". *North China Herald*, 26 January.
- Nöth, W. (1995). *Handbook of Semiotics*. Bloomington: Indiana University Press.
- Parmentier, R.J. (2015). "Representation, Symbol, and Semiosis: Signs of a Scholarly Collaboration". *Signs and Society*, 3(1), 1-7. <https://doi.org/10.1086/680470>.
- Saussure, F. de (2002). *Écrits de linguistique générale*. Édité par S. Bouquet; R. Engler. Paris: Gallimard.
- Schiffirin, H. (1970). *Sun Yat-Sen and the Origins of the Chinese Revolution*. Berkeley: University of California Press.
- Sforza, C. (1929). "Why Sun Yat-Sen Rules Even in Death". *The China Weekly Review*, 25 May.
- Shirvani, S. (2018). "Making Histories of 'Sacred' Mausoleums". *Traditional Dwellings and Settlements Review*, 29(2), 55-71. <https://www.jstor.org/stable/26877323>.
- Sun, J. (2021). *Revisiting China's Modernity: Ethnicity, Religion, and Nation*. New York: Peter Lang.
- Thellefsen, T.; Sørensen, B. (2014). *Charles Sanders Peirce in His Own Words: 100 Years of Semiotics, Communication and Cognition*. Vol. 14, *Semiotics, Communication and Cognition*. Boston: Mouton; Berlin: De Gruyter. <https://doi.org/10.1515/9781614516415>.
- Tjio, K. (2017). *The Unfinished Revolution: Sun Yat-Sen and the Struggle for Modern China*. Singapore: Marshall Cavendish Editions.
- Wagner, R. (2011). "Ritual, Architecture, Politics, and Publicity During the Republic: Enshrining Sun Yat-Sen". Cody, J.; Steinhardt, N.; Atkin, T. (eds), *Chinese Architecture and the Beaux-Arts*. Hong Kong: Hong Kong University Press, 236-78.
- Wagner, R. (2017). "Nanjing: 1925-1928: Enshrining the Father of the Republic". *China Heritage Annual*. <https://chinaheritage.net/annual/2017/republic/tombs-and-palaces/enshrining-sun-yat-sen>.
- Wells, A. (2001). *The Political Thought of Sun Yat-Sen: Development and Impact*. London: Palgrave Macmillan.

- Williams, R. [1976] (1988). *Keywords: A Vocabulary of Culture and Society*. London: Fontana.
- Wong, J.Y. (1986). *The Origins of an Heroic Image: Sun Yat-Sen in London, 1896-1897*. Oxford: Oxford University Press.
- Wydra, H. (2012). "The Power of Symbols: Communism and Beyond". *Internationals Journal of Politics, Culture, and Society*, 25(1/2), 49-69. <https://www.jstor.org/stable/23279944>.
- Yeh, W. (2000). *Becoming Chinese: Passages to Modernity and Beyond*. Stanford: University of California Press.
- Zarrow, P. (2006). *Creating Chinese Modernity: Knowledge and Everyday Life, 1900-1940*. New York: Peter Lang.

**The Historian's Gaze**  
Essays on Modern and Contemporary China  
in Honour of Guido Samarani  
edited by Laura De Giorgi and Sofia Graziani

# Gauging the Tide: the Rise of Nationalist China in Japan's Leading Newspapers, 1928-29

Andrea Revelant  
Università Ca' Foscari Venezia, Italia

**Abstract** The capture of Beijing by Nationalist forces in June 1928 marked the beginning of a new phase in Sino-Japanese relations, as political developments in China impacted on issues such as treaty revision and Japan's interests in the Northeast. Although negotiations did not bring a solution to those fundamental questions, there was some diplomatic progress that, one year later, led to Tokyo's recognition of the Nanjing government. How did the Japanese press respond to this process? To provide a baseline for broader surveys, this essay compares the stances of the two largest newspapers, considering their assessment of both domestic and foreign factors. The analysis shows that the *Asahi* and the *Mainichi* differed to a significant degree in their respective interpretations of the facts.

**Keywords** Asahi. Mainichi. Nanjing government. Tanaka cabinet. Manchuria. Unequal treaties. Jinan incident. Huanggutun incident.

**Summary** 1 Introduction. – 2 Early Reactions to the Nationalist Victory. – 3 On Nationalist China. – 4 On Japan's China Policy. – 5 On the Opposition and the Great Powers. – 6 On Manchuria. – 7 Conclusions.

## 1 Introduction

Discourse and narratives in the mass media are an essential aspect of international politics. Yet most research on Sino-Japanese relations in the early years of Nationalist rule – that is, before the Manchurian incident – has treated press sources in a sporadic fashion, focussing instead on official documents. As a result, it is still difficult



Edizioni  
Ca' Foscari

**Sinica venetiana 10**  
e-ISSN 2610-9042 | ISSN 2610-9654  
ISBN [ebook] 978-88-6969-723-4 | ISBN [print] 978-88-6969-724-1

**Peer review | Open access**  
Submitted 2022-07-26 | Accepted 2022-09-17 | Published 2023-10-11  
© 2023 Revelant | © 4.0  
DOI 10.30687/978-88-6969-723-4/006

to appreciate the interplay between institutional actors and public opinion in that period. The present essay aims to partly fill this gap through a comparative analysis of all the editorials on China published in Japan's two largest newspapers, the *Ōsaka Asahi shinbun* and *Ōsaka Mainichi shinbun* (hereafter *Asahi* and *Mainichi*), over the span of 13 months, from June 1928 to June 1929. The period examined goes from the conclusion of the Northern Expedition to the fall of the Tanaka Giichi cabinet (in office from 20 April 1927 to 2 July 1929), encompassing a number of events that significantly affected the relations between the two countries [tab. 1]. The range is broad enough to allow us to grasp how writers addressed bilateral issues, as the progress of Chinese reunification under the Nationalist Party was putting more and more pressure on Japanese diplomacy to search for viable solutions.<sup>1</sup>

At that time, Japan had a highly developed newspaper market, which rested on mass literacy and fierce competition between commercial media companies. Policy debates in the press were quite free, as government censorship chiefly targeted those views that called the foundations of state authority into question, such as pro-Communist arguments.<sup>2</sup> Since the Meiji period (1868-1912), newspapers had been playing an important role in the construction of the modern Japanese nation as an 'imagined community'. Public opinion on foreign affairs and national interests, as conveyed through the mainstream media, was a force that policy-makers could not ignore. This is especially true for the 1920s, when the two main political parties ruled alternatively.<sup>3</sup>

---

A draft of this article was discussed in May 2022 at the 16th Conference of the Nordic Association for the Study of Contemporary Japanese Society (NAJS). I am grateful to each participant, especially the two discussants Andrea Germer and Dick Stegewerms. I also wish to express my thanks for the comments I received at the 6th meeting of the Kindai Nihon media kenkyūkai and at the 2nd meeting of the Nihon seiji gaikōshi kenkyūkai (Kyoto University), both held in August 2022.

**1** On Japan's China policy under the Tanaka cabinet, see Usui 1971, 61-204; Iriye 1973, 163-253; Usui 1998, 1-17; Hattori 2001, 191-251; Satō 2009; Kitano 2017.

**2** On the expansion of press readership, see Yamamoto 1981; Huffman 1997; Ariyama 2009. For a comprehensive treatment of government-press relations in the imperial era, see Kasza 1988; Sasaki 2013.

**3** On domestic politics in Japan at the time of the Tanaka cabinet, see Murai 2014, 21-88.

**Table 1** Timeline of main events

China's relations with Japan and the other powers		China's domestic situation	
<b>1928</b>			
5.3-11	Jinan incident. Japanese occupation continues until May 1929.		
5.18	Tanaka cabinet's warning to the Northern and Southern governments.	6.4	Huanggutun incident (6.21 Zhang Zuolin's death confirmed officially).
		6.8	The Nationalist Revolutionary Army enters Beijing.
		7.3	Zhang Xueliang takes office as new leader of the Three Eastern Provinces. Negotiations with the Nationalists follow.
7.7	Nanjing government's statement on abrogation of the unequal treaties.		
7.18-8.2	First round of official negotiations with Japan.		
7.19	Nanjing notifies Japan the expiration of the bilateral trade treaty (7.20).		
8.9	UK-China agreement on the Nanjing incident of March 1927.	8.1-15	5th Plenum of the Nationalist Party Central Executive Committee in Nanjing.
7.25	US-China treaty on tariffs.	8.12	Under Japanese pressure, Zhang declares talks with Nanjing suspended.
		10.10	Inauguration of the reorganised Nationalist government in Nanjing, with Chiang Kai-shek as president.
10.19-26	Second round of negotiations with Japan.		
11.3	US officially recognises the Nationalist government.		
12.19	UK-China treaty on tariffs.		
12.20, 22	UK and France officially recognise the Nationalist government.		
12.22	Northeast forces seize from the Soviets the CER telecom HQ in Harbin.	12.29	Zhang raises the Nationalist flag in the Northeast.
<b>1929</b>			
1.25, 3.28	Third round of negotiations with Japan.	1.10	Zhang has his rivals Yang Yuting and Chang Yinhuai executed.
1.19	China-Japan agreement on tariffs (ratified by Japan 1.30).	1.17	Resolution of the demobilisation conference in Nanjing
3.28	China-Japan agreement on the Jinan incident (decided 3.24).	3.15-28	3rd National Congress of the Nationalist Party in Nanjing. Guangxi clique's opposition to the central government escalates into rebellion.
		4.5	Nanjing's army captures Wuhan
5.2	China-Japan agreement on the Nanjing and Hankou incidents of March-April 1927 (laid out 4.14, 4.16).	5.15	Feng Yuxiang joins the rebellion against Chiang Kai-shek, but some of his commanders switch sides.
5.27	Chinese police raids the Soviet consulate in Harbin.	5.27	Feng Yuxiang announces his retirement.
6.3	Japan recognises the Nationalist government (preannounced 5.21).	6.1	Reinterment ceremony for Sun Yat-sen in Nanjing.

The findings presented here complement previous studies on press coverage of the Northern Expedition (Revelant 2017; 2018), the Jinan and Huanggutun incidents (Tamai Kiyoshi kenkyūkai 2015; 2009), and the later Central Plains War (Shimada 2013). They also integrate a selective review of China-related editorials from the *Asahi* (Gotō 1987), extending from 1911 to 1931, and research on individual journalists and columnists (Fujimura 2013, 160-214; Masuda 2017, 99-110; Shimada 2017; 2018), as well as on the liberal economic magazine *Tōyō keizai shinpō* (Eguchi 1973, 355-70). Taken together, these works illustrate the diversity of political views that were circulating in Japan in those years. They also indicate, however, that the army could effectively use its power to grant or deny access to sensitive information, so as to manipulate news and avoid claiming responsibility for its actions.

Specifically, Gotō has noted that the *Asahi* adopted a sympathetic tone towards the Nationalist Party as its armies rolled through Southern China (1987, 249-53), and maintained it consistently through the following years (for the period discussed here, cf. 296-311).<sup>4</sup> Shimada (2013) has found that this approach contrasted with the turn against the Nanjing government that the *Mainichi* took during the civil war of 1930. Revelant (2017) has observed that over the course of 1927-28 the *Tōkyō Asahi shinbun* gradually came to share the stance of its senior partner in Osaka, while the *Mainichi* maintained a chiefly pessimistic view of developments on the continent. This leads to the hypothesis, to be verified here, that – contingent reasons aside – the *Mainichi*'s hostile turn in 1930 may have stemmed from a longer process of critical appraisal, which culminated in a negative view of Chiang Kai-shek's regime. The other two surveys, conducted by teams of students under the supervision of Tamai Kiyoshi, have targeted a broader sample of newspapers and magazines. Although they do provide a wealth of evidence and an assessment of certain trends, their analysis conflates different kinds of articles, from editorial comments to correspondents' reports, interviews and occasional contributions by other writers.

To lay a solid foundation for future surveys, the method adopted here will be to restrict the discussion to editorials, which defined the newspaper's line, as distinct from individual opinions. Hence, these articles were always unsigned.<sup>5</sup> We shall consider only the *Asahi* and

<sup>4</sup> Dates in italics appear further in the text to mark those articles that Gotō has cited in his volume. There was a consonance of views between the *Asahi* and Yoshino Sakuzō (1878-1933), the liberal political scientist and columnist whose thought is the object of the above-cited study by Fujimura.

<sup>5</sup> A notable exception is the Tokyo-based *Kokumin shinbun*, which relied on some well-known authors to attract readers. The staff members forming the board in charge of editorials at the *Asahi* and *Mainichi* were listed annually in Japan's main newspaper yearbook (*Nihon shinbun nenkan* 1921-40. On the period discussed here, see the volume for 1929, part 3: 139, 143). Gotō (1987) has identified the author of most editori-

*Mainichi*, because they can serve as a benchmark for broader press surveys. Standing out from their competitors in Western Japan, they ranked at the top on the overall national market. The two newspapers that ranked immediately below them in terms of circulation were their partners in the respective publishing groups, namely the *Tōkyō Asahi shinbun* and *Tōkyō Nichinichi shinbun*. Compared to Osaka, Japan's capital was home to a larger number of second and third-tier newspapers, resulting in smaller market shares for the big ones.<sup>6</sup> Both *Asahi* and *Mainichi* were commercial enterprises that operated independently from the government and political parties. While scholars usually acknowledge the former as representative of inter-war liberal thought in the urban milieu, research has not yet clarified the character of the latter. Over the course of the period surveyed here, the *Asahi* featured 65 editorials on China, while those in the *Mainichi* numbered 72. Among the latter, 13 were also published in the exact same form in the *Tōkyō Nichinichi* (see Bibliography).

## 2 Early Reactions to the Nationalist Victory

In the *Mainichi*, the conclusion of the Northern Expedition spurred security concerns, which went hand in hand with a rather cold attitude towards the Nationalists (6.1; 6.4; 6.9; 6.12; 6.20; 6.23; 7.10). Concerning both the party and its military forces, the editorialist regretted that “we can't place sufficient trust in them”. He noted that behind slogans such as “smash the unequal treaties” lay an army “filled with a plundering spirit” that would not “gladly respect Japan's legitimate rights”. Therefore, Japan should be temporarily allowed to “protect [those rights] by itself”. The writer approved the warning that the Tanaka cabinet had delivered to the Beijing and Nanjing governments in May to prevent the spread of civil war in Manchuria (6.1). He further urged the cabinet to arrange adequate

---

als on China as Kamio Shigeru, who also served as Head of the China desk in the period examined here. Sawamura Yukio, Head of the China desk at the *Mainichi*, was an editorial board member as well.

<sup>6</sup> The most detailed survey concerning the daily circulation of newspapers for the early Shōwa era (1926-45) is provided by a collection of police reports for November 1927 addressed to the Police Affairs Bureau of the Home Ministry (Keiho kyoku 1979). According to this source (7, 28), at the end of the month the *Asahi* issued 1,260,596 copies and the *Mainichi* 1,166,432, while the *Tōkyō Asahi* and *Tōkyō Nichinichi* printed about 400 and 450,000 copies, respectively. Company data (*Asahi shinbun* 1979, tab. “Asahi shinbun sōkan irai no busū no suii [Changes in the Number of Copies of the *Asahi Shinbun* Since Its Founding]”, unnumbered page after 621; *Mainichi shinbun* 2002, vol. *Bekkan*, 97) do not allow a precise comparison, because they refer to different seasons: for the *Asahi*, the figures are 922,900 in 1928 and 966,400 in 1929, as of 20 May; for the *Mainichi*, they are 1,370,291 in 1928 and 1,503,589 in 1929, as of 1 January (typically the day with highest sales).

defences in the Beijing-Tianjin area together with the other powers, as provided for by the treaties (6.4). In his view, one could foresee that the likely formation of a coalition government under Chiang Kai-shek, Feng Yuxiang and Yan Xishan would not lead to “the great goal of peace and unity”, but rather “produce a completely opposite phenomenon” (6.4). In the long run, it was still uncertain whether the alliance between factional leaders in the Nationalist camp would hold (6.9) and pave the way to demobilisation, which was not an easy task anyway (7.10).

Although the Nationalists did not advance beyond the Great Wall, the situation in Manchuria following the assassination of Zhang Zuolin warranted special attention. It was too early to tell whether his son and successor would be able to

protect the territory and bring peace to the people in the Three Eastern provinces, as well as resist the rising power of the South, and entertain amicable relations with Japan and Russia. (6.20)

The editorialist pointed out that the Marshal had “met a tragic fate” because, carried away by his ambition to control the national government, “he had forgotten about the geographical and political relations” between his home region and neighbouring countries (6.20). These remarks suggest that the *Mainichi* favoured the preservation of an autonomous regime in the Northeast. However, once it became clear that Zhang Xueliang was negotiating with the Nationalists, the commentator conceded that a political deal was desirable to avoid the resumption of warfare (7.10). He disapproved of Tanaka’s attempt to forestall a North-South agreement by putting pressure on Zhang, and regarded it as counterproductive. More broadly, he expressed “extreme concern” about the hard-line turn of the cabinet’s China policy, and advised “deep reconsideration” on the matter (7.25).

The *Asahi* held a more positive view of the Nationalists’ successful thrust into the North. Dismissing security concerns, it greeted the capture of Beijing as “a pivotal event in the history of the Chinese Revolution”, and expressed a confident expectation that Southern authorities would lead the construction of an orderly country with the support of foreign powers. The new phase should include a shift “from clash to accord” in Nanjing’s diplomacy (6.9). In the author’s opinion, there were encouraging signs about the factional leaders’ willingness to set aside their rivalries (6.14a; 6.28). Regarding Manchuria, the *Asahi* too opposed attempts to prevent a North-South deal (7.6). Differently from the *Mainichi*, however, it advocated a bold revision of Japan’s continental policy. While the Northern Expedition was still in progress, the newspaper had advised Tokyo to engage the Nationalists and settle the question of Japanese interests in Manchuria with them, rather than Zhang (4.12; 5.20). After Zuolin’s death, the



editorialist recommended that the cabinet “avoid becoming trapped in past karma” (6.14b), and act instead as “a bridge” to facilitate a “new relationship between the South and the Three Eastern provinces” (7.6). To further its own interests, Japan should discard the current defensive posture that ignored the South, and “get closer to the force that has the greatest say over stability” in the Northeast (7.6).

### 3 On Nationalist China

If, according to the *Mainichi*, Japan's hardening meant that the military and the Premier's entourage had prevailed over diplomats, the newspaper also put a share of the blame on the Nationalists, who had renewed their demand for the immediate abrogation of the unequal treaties (7.25). The Nationalists' return to a militant posture, after a period of moderation following their breakup with the Communists in 1927, was the object of repeated censure in the newspaper (7.16; 7.19; 7.21; 7.25; 7.27; 8.8; 8.10; 8.18). What they had established in Nanjing was “clearly a xenophobic government, unreasonable and unlawful” (7.16). The editorialist observed that within the party there were “domestic reasons for its return to a childish approach” in foreign policy matters (7.19). In other words, its leaders were currying popular favour through an aggressive foreign policy. With a financial metaphor, the writer hinted at the legacy of Soviet coaching in the party:

The statement by Foreign Minister Wang [Zhengting] concerning the abrogation of the treaties is an attempt to settle in full - at foreign countries' expense - a bill that was issued as a slogan for domestic politics; that's the way they do things in Soviet Russia. (7.27)

The advice to Chinese leaders, then, was to mend their ways and follow the lesson Japan could offer them:

[If] Japan has come to occupy an important position internationally as a first-rank country, that is because, unlike the Chinese people of today, it was driven by ardent patriotism to pursue first the repletion of its national strength by striving for domestic improvements. At the same time, when it comes to other countries, it has respected international justice and customs with prudence and good faith, thus building its path step by step. (8.8)

Regrettably, instead,

China has not given the least sign of self-examination or gratitude; behaving outrageously, it has presented us with a great affront, the Nanjing incident. Moreover, [...] it has displayed an unlawful

attitude in its attempt to encroach on our established rights and interests. On top of that, domestically it is deceiving the people, while spreading false propaganda across the world; it is trying to bring Japan down by deceitful means. (8.18)

Consequently, the *Mainichi* supported Japan's diplomacy in its refusal to acknowledge Nanjing's denunciation of the trade treaty, along with its offer to discuss a revision of it on the basis of the valid text (8.10). The ongoing boycotts of Japanese goods, and other protests in China, were occasionally the main topic of editorials, which examined the problem from various angles (12.11; 12.15; 12.17; 1.16; 4.24; 5.8). In the writer's opinion, the anti-Japanese movement had grown so much at the instigation of the Nationalist Party that it was beyond Nanjing's means to stop it (10.25; 3.26). Indeed, he observed, radical groups (12.15), as well as the Guangxi clique (1.16), were fueling protests to weaken Chiang Kai-shek, who understood the danger posed by uncontrolled xenophobia (12.17). This notwithstanding, the author placed some trust in Nanjing's ability to at least restrain the boycotts (4.24). He went as far as to demand effective action in that direction as a precondition for negotiating a treaty revision (6.25).

Comments on bilateral negotiations should be read in conjunction with those on the ability of the Nationalist Party and government to overcome factional strife (8.26; 10.5; 10.10; 12.27; 1.5; 1.16; 3.8; 3.16; 3.21; 3.23; 4.9; 5.19; 5.26; 6.22). Until the latter part of the period under investigation, the *Mainichi* lamented that "there seems to be little reason for optimism", as "there is in them no fixed view, either in terms of thought or politics, nor do they have any moral compass" (8.26).

The editorialist reproached more benevolent observers in Japan, stating that he had "kind of an odd feeling from the fact that some people constantly propagandise the successes of the Nanjing government" (9.5).

The launching of a reorganised central administration in October did not lead to any marked improvement of such judgment because, according to the writer, the enduring rivalries within the party meant that no real progress had yet been achieved (10.5). If anything, from March 1929 or thereabouts, the break between Chiang Kai-shek and the new Guangxi clique cast the Nationalist leadership in an even more negative light:

We are really appalled that the deeds of what is called the Nationalist Party do not differ in the least from the old military cliques, which had neither ideals nor principles. (3.23)

Although Chiang soon forced his opponents to retreat from Wuhan, the editorialist objected that this was not enough to prevent armed

resistance from emerging again, as the political reasons for dissent were still in place (4.9). It seemed as though the “new military cliques” were heading towards the same kind of “feudalistic territorialism as the old military cliques” (5.19).<sup>7</sup>

After the rebels suffered several defections, however, the *Mainichi* adopted a more optimistic tone, claiming that “small waves on a local scale and resistance by a minority of people are not enough to change the direction of the general trend” (5.26).

Although disturbances in China were inducing many Japanese to look at that country once again with a “derisive attitude”, it should not be forgotten that

peace and unity, like the two Rivers that flow eastward and pour into the sea, are the general trend in China. [...] By taking pleasure in the waves in vain, there is a risk of failing to see the essential flow of the tide. (6.22)

Apparently, the consolidation of Chiang Kai-shek's power persuaded the *Mainichi* that it would be better to deal with his regime in a more constructive spirit. A concurrent factor in this reappraisal was the conclusion of Sino-Japanese negotiations over past incidents, namely: those that had occurred in Nanjing and Hankou in March-April 1927, and the more serious military clash in Jinan. These agreements paved the way to the official recognition of Nanjing as the legitimate government of all China.<sup>8</sup>

The *Asahi*, instead, was steady in its support for the Nationalist government. The only departure from this stance occurred after 19 July 1928, when Nanjing confirmed its intention to regard the trade treaty with Japan as expired. The editorialist, who had expected a moderate turn in Chinese foreign policy (7.12; 7.19), reacted to the announcement with a vigorous protest (7.21). Nevertheless, he was soon able to revert to a more cordial tone, as the government failed to translate its words into action. As bilateral negotiations were taking their tortuous course, the *Asahi* choose to devote only one editorial to the problem of trade boycotts. Moreover, when it touched on that issue it was to denounce Tanaka's inept diplomacy, which had been

<sup>7</sup> Another derogatory opinion had been expressed in an earlier article by journalist Murata Shirō, an expert on Chinese affairs working for the *Mainichi* group: in his view, the Nationalist army and government were “nothing more than military cliques disguised under the name of the Three Principles of the People” (3.24).

<sup>8</sup> Among the newspaper's contributors, the only one who conveyed an optimistic view of China well in advance of the editorial turn was liberal essayist Hasegawa Nyozezan. In the final instalment of a long article (1.19), he predicted that under the Nationalist government China would use its vast resources to grow into a modern state, and become one day the United States of Asia.

a cause of resentment among the Chinese (12.16; 1.9). The newspaper also remained supportive of Chiang's efforts to centralise power and keep the radical Left outside the administration (9.25; 12.27; 1.3; 2.28; 3.7; 3.14; 3.21; 4.7; 4.11; 5.3; 5.16; 5.23b; 5.30; 6.13; 6.29).<sup>9</sup> The failure of rebellions was invoked as proof that Nanjing was able to guarantee order in China (4.7). While factions such as that of Feng Yuxiang stood for "territorial allotment and feudalism", the one led by Chiang, despite its defects, represented "unity and stability" (5.23b). Therefore, the *Asahi* welcomed Tokyo's belated decision to recognise the Nanjing authorities as China's government, and expressed hopes that an internationally acknowledged status would help the latter to put down any disturbances (5.23a).

#### 4 On Japan's China Policy

Whereas the *Mainichi's* assessment of Nationalist rule in China varied over time, it held fast to a harsh view of Japanese diplomacy under Premier Tanaka, who concurrently held the post of Foreign Minister. This criticism did not concern so much the fundamental objectives in terms of national policy, which consisted in the protection of Japan's rights to the broadest possible extent. The newspaper was rather dissatisfied with the cabinet's attitude and choice of means, which it deemed ineffective, if not outright harmful. As a former army general, Tanaka lacked "a polished method" and inevitably raised suspicions among the Chinese with his aimless talk about "vigorous diplomacy". His cabinet therefore could not help giving "an impression of militarist politics", even when it behaved correctly (8.18). In contrast with Britain and the United States, the administration lacked an understanding of the importance of the press for public communication. This deficiency made Japan vulnerable to astute Chinese propaganda, both on the continent and in "Euro-America" (8.22).

In so far as the *Mainichi* wanted Japan to conduct treaty negotiations without haste (8.15; 9.5; 10.25) and with a firm stand in defence of the existing legal framework (9.16), it had no particular reason to complain about the government's approach. However, as an advocate of prudence (9.27) and better efforts for mutual understanding (8.18; 10.18), the newspaper strongly disagreed with the cabinet's tactics, such as the decision to suspend talks in the attempt to have Nanjing retract its notice of termination of the trade treaty (9.5; 9.8). It also repeatedly called for the withdrawal of troops from Shandong (6.23; 1.30; 3.30).

<sup>9</sup> The editorialist also showed some sympathy for Nanjing's decision to regain control of the salt tax revenues, which had been placed under international management (11.22).

The editorialist was alarmed at the inconsistency of Japan's diplomacy, which wavered between a fruitless hard-line posture (7.25; 11.19) and the consequent, embarrassing retreats. The path leading to the solution of the Jinan incident was a case in point (11.2; 1.30; 2.12; 3.8; 3.13; 3.26; 3.30). Initially, the cabinet had made four demands to China that reflected the concerns of the Japanese commander in Jinan: they asked for a formal apology, punishment of those responsible, reparations, and guarantees for the safety of Japanese nationals and their property. The agreement reached in March, however, included only a joint expression of regret for the unfortunate episode, and entrusted a mixed committee with the task of assessing damage compensation for both sides. The editorialist felt that in the end Japan had "given in almost entirely to China's claims": "The damage to our national prestige and national glory", he commented, "is by no means small".<sup>10</sup> This blunder would also have "extremely serious consequences for the honour and credit of our national army", which had "become the victim of an expedition with political aims" decided by the government (3.13; and again on 3.30). In other words, as at the time of the incident, the *Mainichi* drew a neat distinction between the cabinet and the army, absolving the latter of all responsibility. A few weeks later, the agreement on the Nanjing and Hankou incidents did nothing to improve the writer's opinion about Tanaka. Although Nanjing had accepted the Japanese demands, this had taken so long that it could hardly be considered a success; it seemed, rather, another instance of a "diplomacy of humiliation" (4.18). The only achievement that received a positive reception was the bilateral agreement on tariffs, judged to be satisfactory for both countries. The writer nonetheless pointed out that the real problems were those lying ahead in view of a comprehensive revision of the trade treaty (2.1).

The *Asahi* was even more hostile to the administration. Owing to the "biased and narrow-minded China policy" of his party, the Rikken Seiyūkai, Tanaka had been unable to act beyond a "passive protection of rights", whereas he should have striven to "approach the Southern force and guide the hearts and minds of China". With its aggressive attitude, the government had only caused trouble (7.26; in a similar vein, 8.23). For a few months, the writer detected some encouraging signs of a possible softening on both sides (8.30; 10.18;

---

<sup>10</sup> According to the writer (2.12), a domestic reason for the cabinet's surrender was its haste to settle the problem before the coming Diet session. The *Mainichi* repeatedly accused the government of bending foreign policy to its own petty schemes. This is especially evident in the newspaper's treatment of the unofficial mission to China of Tokonami Takejirō, a breakaway faction leader from the opposition who would later join the majority party. The editorialist dismissed the trip as a pointless, self-serving political manoeuvre (12.4; 12.9; 12.30). The *Asahi*, though doubtful, expressed some hope that the visit might help improve the situation (12.4; 12.13; 12.16; 12.20).

10.27; 11.1). The stalling of negotiations, however, once again led him to attack the cabinet's "high-handed, uncompromising diplomacy" (11.29), its "ineptitude" (12.20), "adventurism", and lack of "liberal spirit" (12.27).

While the *Asahi* welcomed the resumption of talks (1.17), it also stressed that Tokyo had given up its hard-line posture because this had ended in utter failure (1.24; 2.3). Inquiries in the Imperial Diet offered the editorialist an occasion to recapitulate the cabinet's mistakes, starting from its poor understanding of political trends in China (1.31). The newspaper then welcomed the tariff agreement as a promising step towards an orderly revision of the unequal treaties. However, it regretted that the deal had taken the shape of a simple exchange of notes instead of a treaty, as done by other powers. Seen from that angle, it was another lost opportunity for Japan (2.1). Later on, the writer also scolded Japan's businessmen for not pushing for a revision of the treaty (4.25), and lamented the government's slackness (6.23). News of Tanaka's decision to resign, arguably related to the unsolved issue of responsibilities in the Huanggutun incident, came to the editorialist as a relief "for the state and for the people" (6.30). The *Mainichi*, which deplored the absence of an official explanation for the cabinet's resignation, pointed to its considerable unpopularity as a fundamental factor (7.2).

Concerning the Shandong question, the *Asahi* proposed a solution that in substance matched the one the negotiators would reach months later, and which was modelled on the agreements on the Nanjing incident that China had concluded with the United States and Britain (11.1). The newspaper complained about the cabinet's rigid stance as a cause of delays and boycotts (2.6; 2.21; 3.27). Like the *Mainichi*, it considered the government guilty of creating the conditions that had led to the armed clash in Jinan, while it saw Japan's "loyal and brave" soldiers only as victims (12.27). In response to the deal on the Nanjing incident, the *Asahi* approved its content, but again criticised the cabinet for the delay (4.18; 4.25).

## 5 On the Opposition and the Great Powers

In the *Mainichi*, censure of the current Foreign Minister did not imply support for his predecessor Shidehara Kijūrō, who was a close associate of the main opposition party, the Rikken Minseitō. Commenting on a speech Shidehara had recently delivered in Osaka to an audience of businessmen with vested interests in China, the editorialist recalled the main arguments that the public had put forward so far either against or in defence of his policy. Although the writer did not openly take side with those who accused Shidehara of "weak diplomacy", he agreed that the Minister had failed to

prevent the Nanjing incident by underestimating the impending danger. In his opinion, Shidehara's address regrettably left the audience with "the usual feeling that something was missing". In conclusion, he wrote:

What we demand from any cabinet is a policy that really protects our rights and interest in China; there is no need to make distinctions between hard and soft. (9.19)

As for the Minseitō, the *Mainichi* greatly appreciated an earlier resolution of the party, which clarified its position on foreign policy after a long silence following the Jinan incident. The document deserved praise because, through it, the party had discarded its "non-interventionist tendency to do-nothing and plan-nothing", acknowledged "the special character" of the China policy question, and justified the legitimate reaction of the Japanese army to Chinese aggression in Jinan, while at the same time disapproving of the Shandong expedition and demanding rapid withdrawal. Therefore, unlike previous statements by the Minseitō, this one could signal the unity of public opinion in Japan to China and the world (6.23).

The *Asahi*, on the contrary, appreciated Shidehara (5.8, reappraising his handling of the Nanjing incident) more than the Minseitō. According to the editorialist, the party's statement struck a chord in that it called for a shift from "passive" defence to an active policy of amicable cooperation with China. However, it was too lenient towards the cabinet's dangerous actions (6.23). The Minseitō should make a more sustained effort to promote domestic debate for the sake of national interests (7.27), and not distance itself from "Shidehara diplomacy" in an attempt to look more assertive, as this only exposed its lack of confidence (8.9).

Concerning the influence that other countries exerted over Sino-Japanese relations, the *Mainichi* was annoyed by the US decision to strike a deal with China on tariffs without consulting other powers beforehand:

America, while often talking about peace and international cooperation, always betrays its words. (7.29)

America in the past has behaved selfishly in its effort to implement a policy of capitalist penetration; depending on the circumstances at the time, [it has shifted] from unilateralism to cooperation, from cooperation to unilateralism. (8.1)

For a while, the newspaper looked to Britain as a more reliable partner for the "protection of international ethics" against "China's politicians", who were trying to "infringe on the interests of other coun-

tries unlawfully" (11.29). Therefore, the writer could not hide his disappointment when Britain, too, signed a new tariff treaty with China well ahead of Japan (12.22). He later tried to downplay the significance of the agreement (12.29).

With more restrained language, the *Asahi* too dubbed the US initiative "unfriendly" towards the other countries involved (7.31; on China's urge to regain tariff autonomy, see 8.1). Rather than stressing American opportunism, however, the commentator emphasised that Japan was losing ground to the other powers, owing to the "amateur diplomacy" of the Tanaka cabinet (7.28; also 8.13; 1.9; 2.16) and its "pessimistic view" of Chinese politics (1.3). He warned the government, as well as Osaka business circles, against the illusion of seeking British support to counter China (11.29; 1.19).

## 6 On Manchuria

After the initial response to the North-South negotiations, the issue of Japan's special position in Manchuria was brought up in the *Mainichi* only sporadically (8.12; 10.20; 12.31; 1.13; 1.26; 4.16; 5.16). In support of the established rights, the editorialist cited an essay in *The English Review* (July 1928) that was sympathetic to Japan and critical towards US policy towards China (8.12).<sup>11</sup> News that Zhang Xueliang had received an appointment in the new Nanjing government prompted the writer to object that "the truth is an ignominious surrender of the Fengtian faction" (10.10). A little later, Zhang's dilatory tactics on the problem of land leasing rights for Japanese nationals caused further discontent (10.20). When the Nationalist flag was finally raised in the Northeast, the writer saw this development as "sufficient to cause new worries about the position of our country in ManMō [i.e. Manchuria-Mongolia]", and felt obliged to reassert the inviolability of Japan's rights:

our nation's mind when it comes to the protection of these interests is consistent and immutable. It is by no means something that can be swayed or altered depending on the conditions of the authorities in ManMō, or on those of the rulers of China's mainland with respect to ManMō. (12.31)

From this viewpoint, the execution of Yang Yuting at Zhang's orders was bound to have adverse consequences for Japan. The *Mainichi*

---

<sup>11</sup> The anti-US tone peaked in the conclusion of a long article on Japan's rights in Manchuria by Kyoto Imperial University professor Yano Jin'ichi, a specialist of Chinese history (9.11-20). With an Asianist slant, Yano called for close Sino-Japanese cooperation to "lead to repentance the United States, which is concealing the truth of intolerable injustices against both Japan and China".



reckoned that the incident was “one of those that require the highest attention”, since “the Three Eastern Provinces’ relationship with our country is closer than with any other region” (1.13). Nevertheless, the consolidation of Zhang’s power did not induce more explicit reflections in the following months. The autonomy that the Fengtian regime managed to preserve after its formal submission to Nanjing, along with the lack of compelling news, was probably sufficient to keep the question low on the editorial agenda.

Other pieces relating to Manchuria dealt with three issues: the cabinet’s unwillingness to disclose to the Diet the results of the investigation on the Huanggutun incident (1.26); the plan to privatise the Mantetsu (South Manchuria Railway Company; cf. 4.16; 5.16); and Sino-Soviet relations (10.11; 1.12; 5.30; 6.14). With regard to the first topic, the *Mainichi* pressed Tanaka to inform the public thoroughly, so as to dispel suspicions at home and abroad. The writer considered this a requirement in order to overcome the stalemate of official policy in Manchuria (5.16). Regarding the proposal to privatise Japan’s core asset in the region, the newspaper initially endorsed the idea: it seemed like the only way to free the company from political meddling and to reassure China that Japan harboured no aggressive intentions. The writer even recommended that some shares be made available to foreign investors, so as to foster international cooperation. A month later, however, a second editorial reversed this position in light of additional information on the management’s plan. The author concluded that, under the current party administration, the establishment of a board controlled by major shareholders would only “bring the Mantetsu completely into the service of the government”. Moreover, turning to the United States and Britain for loans might “spur their ambitions for direct investment”. As for relations between Zhang’s regime and the Soviet Union, the *Mainichi* noted with some concern the mounting tension over rights on the Chinese Eastern Railway (CER), which would soon escalate into an armed conflict (July-December 1929). At the time, however, the situation in North Manchuria did not yet seem serious enough to require action on Japan’s part.

The *Asahi* pushed its argument for a basic change of policy towards Manchuria even further. It reached the conclusion that Japan should “waive those established rights and interests that exist in name but not in deed”, and “shake hands with the central force in China” to overcome the current stalemate (8.9). It must be stressed, however, that such advice did not mean retreating from the Northeast. The ultimate goal was quite the opposite:

Making this situation, in which Japan is stuck, flexible enough to ensure some development must be the key element in Shōwa Japan’s policy with regard to Manchuria. [...] How could we counter the “force” of China, which is growing day by day, month by

month, only by protecting the old rights and interests? [...] Therefore, our new commitment must be for Japan itself to apply a dissecting scalpel to those established rights and interests which exist in name but not in deed. (8.9)

According to the writer, a 'surgical operation' of this kind was the only way to "make development possible beyond the present state". He did not clarify, though, what the worthless appendages to be cut off were.

Once the South would complete the unification of China, any agreement that Japan might have struck with the Fengtian faction alone would become worthless, or even pose an obstacle to Sino-Japanese understanding (8.9; and again on 8.16; 4.4). Accordingly, the editorialist was not disturbed by the execution of Yang Yuting, who had been opposing Zhang's *rapprochement* with Nanjing. That incident only reinforced his belief that Japan should reckon with the Nationalists' growing influence over Manchuria (1.12). After the Mantetsu President announced his intention to open the company to foreign investors and sell part of its business operations, the writer approved this "open door" policy as a means to dispel international diffidence against Japan. However, he also doubted that similar announcements could bear fruit, as long as the Tanaka cabinet stuck to its "policy of military coercion" (9.13). He severely criticised the Premier for his reticence about the Huanggutun incident, with more insistence than the *Mainichi* (12.27; 4.4; 6.18). By contrast, the Sino-Soviet quarrels did not capture the *Asahi's* attention to the point of becoming the subject of any editorial in this period.

## 7 Conclusions

A comparative analysis of how Japan's two leading newspapers discussed Chinese affairs and Sino-Japanese relations at the early stage of Nationalist rule, as conducted above, reveals that they differed to a significant degree in their respective interpretations of the facts. The *Asahi*, which identified the dominant faction of the Nationalist Party as the only force capable of stabilising China, advocated an active policy of dialogue with the new regime to secure a solid foundation for Japan's economic interests on the continent. This approach involved the rejection of dualistic diplomatic approach to "mainland China" and "Manchuria", of the sort still practiced by the Tanaka cabinet, because the newspaper assumed that the Northeast would become assimilated by the Nationalist state sooner or later.

The *Mainichi* had a more conservative attitude. Although it too was extremely critical of Tanaka's high-handed tactics as detrimental to Japan, its tone towards the Nationalists fluctuated between patronising and derogatory through most of the period examined. The ar-

argument that China still had a long way to go before it could be called a modern state justified a stronger stance for the preservation of Japan's established rights. In particular, the *Mainichi* saw no pressing need to reconsider Japan's position in Manchuria, or its special relationship with the Northeastern regime. In this perspective, Zhang's *détente* with Nanjing appeared more as a threat than an opportunity to pursue a comprehensive solution to pending issues.

Nevertheless, the newspaper's eventual reappraisal of Chinese reunification might indicate that it was starting to accept the prospect of coming to terms with the Nationalists in a more flexible way. While the existing literature provides sufficient grounds to claim that the *Asahi's* basic stance remained unchanged until the outbreak of the Manchurian incident, further research is required to ascertain the extent to which events affected the posture of its main competitor in the second half of 1929, that is during the Sino-Soviet conflict, and after the Central Plains War. In hindsight, it seems that the *Mainichi's* openness to compromise rested on fragile ground, since it took the protection of Japan's core interests in Manchuria as a baseline condition.

On the other hand, Gotō (1987, 300-1) may have overstated the *Asahi's* readiness to give up Manchuria as a Japanese sphere of influence. What the editorialist advocated at that stage was not disengagement from the region, but rather an accommodation with the Nationalist government under a unified China policy. The *Asahi's* stance, therefore, differed from the radical opinion that Japan needed to relinquish its special rights, an opinion which Ishibashi Tanzan had been voicing in the *Tōyō keizai shinpō* since the 1910s (Masuda 2017, 77-86). The *Asahi* did not define the scope of the old rights that Japan needed to waive for the sake of gaining new opportunities. Its policy recommendation stemmed from the assumption that Nanjing would tone down its demands concerning the regaining of sovereign rights.

Once we have ascertained that the two newspapers held different views on Japan's China policy, it is necessary to inquire why this was the case. Neither had proven ties with any political party or other organisation. The *Asahi* was harsher towards the Seiyūkai, but also criticised the Minseitō. Some differences in tone suggest that the *Mainichi* may have had a closer relationship with those business circles that were less willing to undergo a renegotiation of their vested interests in China. At present, though, the evidence is too thin to buttress this conjecture. Another aspect to be considered is the intense competition on the press market. As leading players, both newspapers had an incentive to support views that might appeal to the majority of their potential readership. At the same time, they also strove to acquire a profile that would allow them to stand out from their rivals. Therefore, it is quite safe to conclude that the *Asahi* and the *Mainichi* developed two alternative narratives which both lay within the acceptable boundaries for a large share of the public. In

both cases, however, the question remains to what extent the articles reflect the writers' need to please their readers, and to what extent they represent a genuine effort to lead public opinion. The *Asahi* seemed more inclined to take some risks and keep its line of argument straight, regardless of contingent events.

In any case, the findings presented here suggest that there was still little room for radical assertions in mainstream discourse at the time. Research on other press sources should verify whether mid-size newspapers from this period mostly aligned themselves with the interpretations offered by big ones, or whether they mostly supported arguments that catered to particular segments of society. Finally, it is necessary to stress the inherent weakness of the press as a tool of civilian control over the military. Notwithstanding the anti-militarist mood that prevailed throughout the 1920s, both the *Asahi* and the *Mainichi* accepted the military actions in Jinan as defensive operations, and were unable to bring to light the truth behind Zhang Zuolin's death. Moreover, the *Mainichi* was quite receptive of Nationalist ideas that could justify a harsh reaction in the event of a perceived threat to Japan's vital interests, as would later be the case with the Manchurian incident.

## Bibliography

### Newspapers: *Ōsaka Asahi shinbun*

*Ōsaka Asahi shinbun* 大阪朝日新聞 (digital database: Asahi shinbunsha 朝日新聞社. *Asahi shinbun kurosu sāchi* 朝日新聞クロスサーチ. <https://xsearch.asahi.com/>).

Note: the transcription of article titles uses characters in the simplified standard form. 'Ed.' stands for 'Editorial'.

### 1928

- 4.12. Ed. "Shina hōjin no fuan: tsui ni Manshū ni oyobu" 支那邦人の不安 終に満州に及ぶ (Insecurity of Our Nationals in China: Finally It Reaches Manchuria).
- 5.20. Ed. "Kita Shina no keisei jūdai" 北支那の形勢重大 (Situation of North China Critical).
- 6.9. Ed. "Pekin senryō: aratani kuwawatta Kokumintō no daininmu" 北京占領 新たに加わった国民党の大任務 (Occupation of Beijing: An Additional Great Task for the Nationalist Party).
- 6.14a. Ed. "Shō-shi no jinin: daidō danketsu no kōkikai" 蔣氏の辞任 大同団結の好機会 (Mr Chiang's Resignation: A Valuable Opportunity for a United Front).
- 6.14b. Ed. "Chō-shi no fu to Manshū chian mondai" 張氏の訃と満州治安問題 (Mr Zhang's Obituary and the Issue of Manchuria's Security).

- 6.23. Ed. "Tai Shi mondai kaiketsu: Minseitō to Seiyūkai no tachiba" 対支問題解決 民政党と政友会の立場 (A Solution to Issues with China: The Stances of Minseitō and Seiyūkai).
- 6.28. Ed. "Pekin no kyotō kaigi: antei ka ina ka bunkiten" 北京の巨頭会議 安定か否か分岐点 (Leaders' Conference in Beijing: Stability at a Crossroads).
- 7.6. Ed. "Tōsanshō no antei: Nihon no taido ga kan'yō" 東三省の安定 日本の態度が肝要 (Stability of the Three Eastern Provinces: Japan's Posture Is Vital).
- 7.12. Ed. "Kokumin seifu no taigai hōshin: kyūshinka wa fuka" 国民政府の対外方針 急進化は不可 (The Nationalist Government's Foreign Policy Line: Radicalisation Won't Do).
- 7.19. Ed. "Tai Shi gaikō no honbutai: korekara ga sōkessan" 対支外交の本舞台 これからが総決算 (China Policy on the Real Stage: Final Settlement Ahead).
- 7.21. Ed. "Jōyaku haiki wa fuhō" 条約廃棄は不法 (Treaty Denunciation Is Illegal).
- 7.26. Ed. "Iyoioy setsuretsu o kiwamu: waga tai Shi gaikō" いやいよ拙劣を極む わが対支外交 (More Than Ever the Height of Ineptitude: Our China Policy).
- 7.27. Ed. "Minseitō no tai Shi seimei" 民政党の対支声明 (The Minseitō's Statement on China).
- 7.28. Ed. "Amerika no shin tai Shi saku: Nihon tonō taishō" アメリカの新対支策 日本との対照 (America's New China Policy: Contrast with Japan).
- 7.31. Ed. "Bei-Shi shinjōyaku: rekkoku kyōchōnan" 米支新条約 列国協調難 (New US-China Treaty: Cooperation Between Powers Difficult).
- 8.1. Ed. "Shina no omowaku: futatabi Bei-Shi shinjōyaku ni tsuite" 支那の思惑 再び米支新条約に就て (China's Expectations: Once More on the US-China New Treaty).
- 8.9. Ed. "Genjō iji kanō nari ya: Tōsanshō o dō suru" 現状維持可能なりや 東三省をどうする (Is Keeping the Status Quo Possible? What Shall We Do with the Three Eastern Provinces?).
- 8.13. Ed. "Ei-Shi sekkin: Nankin jiken kaiketsu saru" 英支接近 南京事件解決さる (Britain-China Rapprochement: Nanjing Incident Solved).
- 8.16. Ed. "Tōsanshō no kōhai fumei: waga taisaku wa mokuzenteki tare" 東三省の向背不明 我が対策は目前的たれ (Attitude of the Three Eastern Provinces Unclear: Our Response Is Short-Sighted).
- 8.23. Ed. "Ikizumatta Nisshi gaikō: sumiyakani dakai o sakuse" 行詰った日支外交 速かに打開を策せ (Japan-China relations at a Deadlock: Find a Way Out Quickly).
- 8.30. Ed. "Nisshi jōyaku kōshō: sokkai o kanō narashimeru jōken" 日支条約交渉 速開を可能ならしめる条件 (Japan-China Treaty Negotiations: Conditions that May Lead to a Rapid Resolution).
- 9.13. Ed. "Mantetsu no shinkeizaisaku" 満鉄の新経済策 (The New Economic Policy of the Mantetsu).
- 9.25. Ed. "Migi suru Nankin: Nisshi kōshō dakai no ki" 右する南京 日支交渉 打開の機 (Nanjing Veers to the Right: A Chance to Solve Japan-China Negotiations).
- 10.18. Ed. "Waga tai Shi saku: sekkyokuteki ni ideyo" わが対支策 積極的に出でよ (Our China Policy: Take Up a Positive Attitude!).
- 10.27. Ed. "Nisshi ken'an kaiketsu: ryōkoku kankei kōten sen" 日支懸案解決 両国関係好転せん (A Solution to Pending Japan-China Problems: Bilateral Relations Improve).

- 11.1. Ed. "Ōi ni tenkan o hakare: Arita kyokuchō no Shanhai yuki" 大に転換を図れ 有田局長の上海行 (Strive for a Change! Bureau Chief Arita Goes to Shanghai).
- 11.22. Ed. "Mata ichifunkyū: Shina no enzei kaishū seimei" また一紛糾 支那の塩税回収声明 (More Trouble: China's Statement on the Recovery of the Salt Tax).
- 11.29. Ed. "Doko made gyakkō ka: dassen seru tai Shi gaikō" 何処まで逆行か 脱線せる対支外交 (Going Backwards Forever? A Derailed China Policy).
- 12.4. Ed. "Tokonami-shi tōshi: shin ni seijika rashikushintai seyo" 床次氏渡支 真に政治家らしく進退せよ (Mr Tokonami Crossing to China: Act Like a Politician Should!).
- 12.13. Ed. "Tanaka gaikō no kyōsei: Tokonami-shi ni ataerareta kōkikai" 田中外交の匡正 床次氏に与えられた好機会 (Redressing Tanaka Diplomacy: Mr Tokonami Offered a Good Chance).
- 12.16. Ed. "Tokonami-shi to haiNichi: konponteki kyūjissaku o tateyo" 床次氏と排日 根本的救治策を立てよ (Mr Tokonami and Anti-Japan: Work Out How to Solve the Problem at the Root!).
- 12.20. Ed. "Shina mondai o chūshin ni: gikaimae no seikyoku tenbō" 支那問題を中心に 議会前の政局展望 (China Question at the Center: Outlook of the Political Situation Before the Diet Session).
- 12.27. Ed. "Konnen no Shina: Nisshi gaikō hatan no toshi" 今年の支那 日支外交破綻の年 (This Year's China: The Year Japan-China Diplomacy Broke Down).

## 1929

- 1.3. Ed. "Shina seikyoku no tenbō: hikan kara rakkan e" 支那政局の展望 悲観から楽観へ (Outlook on the Political Situation in China: From Pessimism to Optimism).
- 1.9. Ed. "Sanshoku saruru waga shōken" 蚕食さるるわが商権 (Our Rights to Commerce Encroached).
- 1.12. Ed. "Yō-shi ippa no botsuraku" 楊氏一派の没落 (Downfall of Mr Yang's Faction).
- 1.17. Ed. "Yoshizawa kōshi no kinin" 芳澤公使の帰任 (Minister Yoshizawa Back on Duty).
- 1.19. Ed. "Ōsaka ni Nichi-Ei kyōkai: omoichigai o suru na" 大阪に日英協会 思い違いをするな (Japan-UK Association in Ōsaka: Don't Take It Wrong).
- 1.24. Ed. "Nisshi kōshō ikan: Tanaka naikaku saigo no ikkatsuro" 日支交渉如何 田中内閣最後の一活路 (How Are Japan-China Negotiations Going? Last Way Out for the Tanaka Cabinet).
- 1.31. Ed. "Tai Shi seisaku no kekkai: gikai no mondō kara bakuro sareta" 対支政策の欠陥 議会の問答から暴露された (Shortcomings of the China Policy: Exposed by Interrogation in the Diet).
- 2.1. Ed. "Nisshi kanzei kyōtei naru" 日支関税協定成る (Japan-China Tariff Agreement Reached).
- 2.3. Ed. "Shidehara-dan no shitsumon enzetsu" 幣原男の質問演説 (Baron Shidehara's Parliamentary Address).
- 2.6. Ed. "Nankin jiken no kaiketsu: futatabi satetsu seshimuru nakare" 南京事件の解決 再び蹉跎せしむる勿れ (Solving the Nanjing Incident: Don't Cause Another Fiasco!).

- 2.16. Ed. “Beikoku no tai Shi seisaku: sarani shinten sen” 米国の対支政策 更に進展せん (US Policy Towards China: Moving Further Ahead).
- 2.21. Ed. “Kōshō seihi no bunkiten: Sainan mondai yukinayamu” 交渉成否の分岐点 済南問題行悩む (Negotiations at a Crossroads: Jinan Problem at a Standstill).
- 2.28. Ed. “Chō Shūshō-shi no kyohei: desaki kanken no mōdō, waga kuni ni-mo furi” 張宗昌氏の拳兵 出先官憲の妄動 わが国にも不利 (Mr Zhang Zongchang Raising Arms: Officials Abroad Acting Recklessly, Bad for Our Country Too).
- 3.7. Ed. “Taikyoku wa ugokumai: Konan mondai kara Shina mata funkyū” 大局は動くまい 湖南問題から支那また紛糾 (The General Situation Won't Change: From the Hunan Problem Trouble Again in China).
- 3.14. Ed. “Kokumintō zenkoku daihyō kaigi: kongo no shinro ikan” 国民党全国代表会議 今後の針路如何 (National Congress of Delegates of the Nationalist Party: What Course Will It Take?).
- 3.21. Ed. “Saihei tojō no ichiharan: kiki ni hinseru Konan mondai” 裁兵途上の一波瀾 危機に瀕せる湖南もんだい (A Commotion on the Path to Demobilisation: Hunan Problem on the Verge of a Crisis).
- 3.27. Ed. “Sainan mondai no kaiketsu: ōi naru kyōkun” 済南問題の解決 大なる教訓 (Jinan Problem Solved: A Great Lesson).
- 4.4. Ed. “Tai Man kōshō yukinayamu: konpon no dakaisaku” 対滿交渉行悩む 根本の打開策 (Negotiations with Manchuria at a Standstill: A Basic Plan for a Way Out).
- 4.7. Ed. “Bukan-gun tsuyu: kongo no yosō ni tsuite” 武漢軍潰ゆ 今後の予想に就て (Wuhan Army Crushed: About Predictions on What Lies Ahead).
- 4.11. Ed. “Shō, Fū hatashite tatakau ka: Shō-shi tsūden no shin'i” 蔣、馮果して戦うか 蔣氏通電の真意 (Will Chiang, Feng Finally Fight? The True Meaning of Mr Chiang's Telegram).
- 4.18. Ed. “San ken'an no kaiketsu: tai Shi sakujō no igi” 三懸案の解決 対支策上の意義 (Solving Three Issues: The Meaning for the China Policy).
- 4.25. Ed. “Jitsugyōkai eno chūmon: Nisshi jōyaku kaitei ni tsuite” 実業界への注文 日支条約改訂に就て (A Request to the Business World: Concerning the Revision of the Japan-China Treaty).
- 5.3. Ed. “Futatabi Shō-Fū kankei ni tsuite” 再び蔣馮関係に就て (Once More About Chiang-Feng Relations).
- 5.8. Ed. “Nankin jiken no kaiko” 南京事件の回顧 (Remembering the Nanjing Incident).
- 5.16. Ed. “Nankin seifu no shiren: shōi o sute daidō ni tsuke” 南京政府の試験 小異をすて大同につけ (Nanjing Government on Trial: Cast Aside Minor Differences, Achieve Unity!).
- 5.23a. Ed. “Kokumin seifu no shōnin” 国民政府の承認 (Recognition of the Nationalist Government).
- 5.23b. Ed. “Shō, Fū no tairitsu: genkyokumen wa ikani tatsu ka” 蔣、馮の対立 現局面は如何に立つか (Chiang-Feng Confrontation: How Will the Current Situation Develop?).
- 5.30. Ed. “Son Bun hōansai” 孫文奉安祭 (Sun Wen's Burial Ceremony).
- 6.13. Ed. “Fū-shi no geya mondai” 馮氏の下野問題 (The Issue of Mr Feng's Retirement).
- 6.18. Ed. “Taigaiteki giwaku o toke: bō jūdai jiken” 対外的疑惑を溶け 某重大事件 (Dispel Suspicions Abroad! That Serious Incident).

- 6.23. Ed. “Konponteki yōkyū o ikase: Nisshi jōyaku kōshō” 根本的要求を活かせ 日支条約交渉 (Make the Most of Basic Demands! Japan-China Treaty Negotiations).
- 6.29. Ed. “Shō, Fū ryōshi no geya” 馮、閻両氏の下野 (Retirement of Messrs Feng and Yan).
- 6.30. Ed. “Naikaku sōjishoku no ketsui: tōzen no unmei” 内閣総辞職を決意 当然の運命 (Cabinet Decides General Resignation: A Deserved Fate).

### Newspapers: *Ōsaka Mainichi shinbun*

*Ōsaka Mainichi shinbun* 大阪毎日新聞 (digital database: Mainichi shinbunsha 毎日新聞社. *Maisaku* 毎索. <https://mainichi.jp/contents/edu/maisaku/login.html>).

Note: editorials in common with the *Tōkyō Nichinichi shinbun* bear the indication “TN”.

### 1928

- 6.1. Ed. “Nankin seifu no kaitō: kogatanazaiku o yamete seii ni kaere” 南京政府の回答 小刀細工をやめて誠意に帰れ (Nanjing Government's Reply: Give Up Petty Tricks, Show Good Faith Again!).
- 6.4. Ed. “Chō Sakurin-shi no taikyō” 張作霖氏の退京 (Mr Zhang Zuolin's Withdrawal from Beijing).
- 6.9. Ed. “Shina kakumei undō no zento” 支那革命運動の前途 (The Outlook for China's Revolutionary Movement).
- 6.12. Ed. “Shō Kaiseki-shi noshintai: ken ni nite obietaru mono ka” 蒋介石氏の進退 賢に似て怯たるものか (Mr Chiang Kai-shek in a Dilemma: Looks Smart, But Might He Be Scared?).
- 6.20. Ed. “Chō Sakurin-shi no fu” 張作霖氏の訃 (Mr Zhang Zuolin's Obituary).
- 6.23. Ed. “Minseitō no tai Shi ketsugibun: daitai ni tō o etaru mono” 民政党の対支決議文 大体に当を得たるもの (The Minseitō's Resolution on China: It Is Quite Right).
- 7.10. Ed. “Yon kyotō kaigi: enman naru seika o nozomu” 四巨頭会議 円満なる成果を望む (Conference of the Four Leaders: Wishing an Amicable Outcome).
- 7.16. Ed. “Nankin seifu no taido: shōki no sata towa omoenu” 南京政府の態度 正気の沙汰とは思えぬ (Attitude of the Nanjing Government: Cannot Be in Its Right Mind).
- 7.19. Ed. “Nisshi jōyaku no kaitei ni tsuite” 日支条約の改訂に就て (Concerning the Revision of the Japan-China Treaty).
- 7.21. Ed. “‘Rinji benpō’ no kyozetsu wa tōzen” 「臨時弁法」の拒絶は当然 (Refusing the ‘Provisional Rules’ is Obvious).
- 7.25 (TN 7.24). Ed. “Seifu no tai Man keikoku: kyōkō ronsha no shōri” 政府の対滿警告 強硬論者の勝利 (Government's Warning to Manchuria: A Victory for Hardliners).
- 7.27 (TN 7.26). Ed. “Ō-shi no kageki gaikō: mikata o teki ni mawasu” 王氏の過激外交 味方を敵に廻す (Mr Wang's Extremist Foreign Policy: Turning Friends into Foes).



- 7.29. Ed. “Bei-Shi shinkyōtei: hayawaza dewa aru ga odoroku niwa ataranu” 米支新協定 早業ではあるが驚くには当らぬ (US-China New Agreement: A Quick Feat but Not a Surprise).
- 8.1. Ed. “Beikoku no tai Shi saku: tsujū no yō nashi” 米国の対支策 追従の要なし (US Policy Towards China: No Need to Follow Suit).
- 8.8. Ed. “Shina no hansei o nozomu: zai yatō no tai Shi seimei” 支那の反省を望む 在野党の対支声明 (Looking Forward to China's Repentance: The Opposition Party's Statement on China).
- 8.10. Ed. “Tai Shi kaitō: Shina wa sumiyakani shōdō ni kaere” 対支回答 支那は速かに正道に還れ (Response to China: China, Get Back Quickly on the Right Path!).
- 8.12. Ed. “Nihon to Manshu: Burando-shi no ronbun” 「日本と満州」ブランド氏の論文 (Japan and Manchuria: Mr Brand's Essay).
- 8.15. Ed. “Nankin jiken no kaiketsu: Nihon wa hikizurareru hitsuyō nashi” 南京事件の解決 日本は引きずられる必要なし (Solving the Nanjing Incident: No Need for Japan to Get Dragged into It).
- 8.18. Ed. “Katana o sutete tatsu: Nisshi ryōkoku ni kibō su” 「刀を棄てて立つ」日支両国に希望す (‘Cast Aside the Sword and Stand Up’: Our Wish for Japan and China).
- 8.22. Ed. “Sekai yoron no shidō: seifu no yarikata wa setsuretsu” 世界輿論の指導 政府の遣方は拙劣 (Leading World Opinion: Government's Course of Action Awkward).
- 8.26. Ed. “Nanboku Shina no tōitsu: taigai seikō yorimo naibu seiri ga kan'yō” 南北支那の統一 対外成功よりも内部整理が肝要 (Unification of North and South China: Rather Than Success in Foreign Relations, Domestic Consolidation Is What Matters).
- 9.5. Ed. “Tai Shi gaikō no genjō: omomuro ni mimamori toechi naki wo ki seyo” 対支外交の現状 徐に見守り手落なきを期せよ (The Current State of Diplomacy with China: Watch Without Haste, Avoid Careless Mistakes!).
- 9.8. Ed. “Nisshi gaikō no katsuro: sōhō tsuyogaru bakari ga nō denai” 日支外交の活路 双方強がるばかりが能でない (A Way Out for Japan-China Diplomacy: Both Make a Tough Face but There Is No Point).
- 9.11-20. Yano Jin'ichi 矢野仁一. “Manshū ni okeru waga tokushu ken'eki” 満州におけるわが特殊権益 (Our Special Rights and Interests in Manchuria).
- 9.16. Ed. “Nisshi gaikō no saijūten” 日支外交の最重点 (The Most Important Point in Japan-China Diplomacy).
- 9.19. Ed. “Shidehara-dan no enzetsu ni tsuite” 幣原男の演説について (Concerning Baron Shidehara's Speech).
- 9.27 (TN 9.26). Ed. “Kyokutō ni okeru futatsu no chikara: sono kokusaiteki kankei” 極東における二つの力 その国際的関係 (Two Forces in the Far East: Their International Relationship).
- 10.5. Ed. “Goin seido no kakuritsu: sumiyakani tōitsu seifu no jitsu o ageyo” 五院制度の確立 速に統一政府の実を挙げよ (Establishment of the Five Yuan System: Show Quickly the Results of a Unified Government!).
- 10.10. Ed. “Kokumin seifu no kaobure: Hōten-ha no kuffuku” 国民政府の顔触 奉天派の屈服 (Lineup of the Nationalist Government: Fengtian Faction Forced to Submit).
- 10.11. Ed. “Rokoku no tai Shi shutsudō: kongo chūmoku o yō su” 露国の対支出動 今後注目を要す (Russia's Dispatch to China: Attention Required for the Future).

- 10.18. Ed. “Nisshi no kyokumen dakai: kobushi ni kōdei sezu taikyoku ni chakugan seyo” 日支の局面打開 小節に拘泥せず大局に着眼せよ (Breaking the Deadlock Between Japan and China: Don't Stick to Trifles, Fix Your Eyes on the Broader Picture!).
- 10.20. Ed. “Shōsoken mondai: Hōten gawa no seii ōshū o nozomu” 商租権問題 奉天側の誠意応酬を望む (The Problem of Commercial Land Leasing Rights: Hoping for a Sincere Reply from Fengtian).
- 10.25. Ed. “Nisshi kōshō no nankyoku: taimen ni torawarezu seii o shu to seyo” 日支交渉の難局 体面に囚われず誠意を主とせよ (Impasse in Japan-China Negotiations: Don't Get Stuck on Appearances, Put Good Faith First!).
- 11.2. Ed. “Nisshi saikōshō: washin no honzen ni tachikaere” 日支再交渉 和親の本然に立返れ (Japan-China Negotiations Resume: Go Back to a Normal State of Amity!).
- 11.19 (TN 11.18). Ed. “Tai Shi kyōkō iken no saishutsugen” 対支強硬意見の再出現 (Reemergence of Hardline View of China).
- 11.29. Ed. “Eikoku no tai Nichi sekkin” 英国の対日接近 (Britain's Rapprochement with Japan).
- 12.4. Ed. “Tokonami-shi no taido: naigai ryōmen no kansatsu” 床次氏の態度 内外両面の観察 (Mr Tokonami's Posture: Observed Both in Terms of Domestic [Politics] and Foreign [Relations]).
- 12.9. Ed. “Moteasobaruru tai Shi gaikō” 弄ばるる対支外交 (Diplomacy to China Reduced to a Trifle).
- 12.11 (TN 12.13). Ed. “HanNichi – hanhanNichi: Shina ni okeru hanNichi-kai – haiNikka” 反日—反反日 支那における反日会—排日貨 (Anti-Japan, Anti-Anti-Japan: Anti-Japan Associations, Boycotts of Japanese Goods in China).
- 12.15. Ed. “Nankin no shinbōkō” 南京の新暴行 (New Assaults in Nanjing).
- 12.17. Ed. “HaiNichi no shinri” 排日の心理 (The Anti-Japanese Mentality).
- 12.22. Ed. “Eikoku no kokumin seifu shōnin” 英国の国民政府承認 (Britain's Recognition of the Nationalist Government).
- 12.27. Ed. “Shina seikyoku tenbō: ichinenjū no gaikan” 支那政局展望 一年中の概観 (Outlook of China's Political Situation: One Year Review).
- 12.29. Ed. “Ei-Shi kanzei jōyaku” 英支関税条約 (UK-China Tariff Treaty).
- 12.30. Ed. “Tanaka Tokonami kaiken” 田中床次会見 (Tanaka-Tokonami Meeting).
- 12.31. Ed. “Manshū ekishi mondai: waga kuni tonon kankei” 満州易幟問題 わが国との関係 (The Problem of Manchuria's Change of Flag: Implications for Our Country).

## 1929

- 1.5. Ed. “Honnen no Shina seikyoku” 本年の支那政局 (This Year's Political Situation in China).
- 1.12. Ed. “Seki-Ro no taido: TōShi tetsudō mondai” 赤露の態度 東支鉄道問題 (Red Russia's Posture: The Chinese Eastern Railway Problem).
- 1.13. Ed. “Yō, Jō nishi no jūsatsu” 楊、常二氏の銃殺 (Messrs Yang and Chang Shot Dead).
- 1.16. Ed. “Kankō no haiNichi” 漢口の排日 (Anti-Japan in Hankou).
- 1.19. Hasgawa Nyozezan 長谷川如是閑. “Kaku no gotoku Shina o miru” 斯くの如く支那を観る (Look at China This Way).

- 1.26. Ed. “Bō jūdai jiken to seifu no taido” 某重大事件と政府の態度 (That Grave Incident and the Cabinet's Posture).
- 1.30. Ed. “Teppeï mondai: izen anshō” 撤兵問題 依然暗礁 (The Problem of Troop Withdrawal: Still Deadlocked).
- 2.1. Ed. “Nisshi kanzei kyōtei no seiritsu” 日支関税協定の成立 (Japan-China Tariff Agreement Reached).
- 2.12. Ed. “Tanaka naikaku wa inseki jishoku seyo: tai Shi gaikō shippai” 田中内閣は引責辞職せよ 対支外交失敗 (Tanaka Cabinet Should Take Responsibility and Resign: The Failure of Diplomacy to China).
- 3.8 (TN 3.7). Ed. “Shina sairān no hō: Kōsei-ha no fuhei” 支那再乱の報 広西派の不平 (News of Another Disturbance in China: Discontent of the Guangxi Faction).
- 3.13 (TN 3.12). Ed. “Santō kōshō kōten no hō: sekinin kaijō to narazu” 山東交渉好転の報 責任解除とならず (News of Improvement in the Shandong Negotiations: It Does Not Mean Release from Responsibility).
- 3.16. Ed. “Kokumintō taikai: bunritsu no mama kaikai” 国民党大会 分立のまま開会 (Nationalist Party Congress: Opening While Still Divided).
- 3.21. Ed. “Kokumintō fuan: saikin no anchō” 国民党不安 最近の暗潮 (Unrest in the Nationalist Party: Recent Undercurrents).
- 3.23. Ed. “Mata sensō ka: Kokumintō no naifun” また戦争か 国民党の内紛 (War Again? Strife Within the Nationalist Party).
- 3.24. Murata Shirō 村田次郎. “Shina no sensō” 支那の戦争 (War in China).
- 3.26. Ed. “Nisshi kyōtei karichōin no hō: tsumaranu atoshimatsu” 日支協定仮調印の報 つまらぬ後始末 (News of Provisional Signing of Japan-China Agreement: A Miserable Settlement).
- 3.30. Ed. “Gaikō shippai no ato: Nisshi kyōtei happyō” 外交失敗の跡 日支協定発表 (The Marks of Diplomatic Failure: Japan-China Agreement Made Public).
- 4.9. Ed. “Nankin-ha no shōri: antei wa gimon” 南京派の勝利 安定は疑問 (Victory of the Nanjing Faction: Stability Doubtful).
- 4.16 (TN 4.16). Ed. “Mantetsu no min'eika” 満鉄の民営化 (Privatisation of the Mantetsu).
- 4.18. Ed. “Nankin Kankō nijiken no kaiketsu” 南京漢口二事件の解決 (Nanjing and Hankou Incidents Solved).
- 4.24. Ed. “HaiNichi to kokumin seifu” 排日と国民政府 (Anti-Japan and the Nationalist Government).
- 5.8 (TN 5.8). Ed. “HaiNichi undō to jōyaku kaitei: seifu no sekinin jūdai” 排日運動と条約改訂 政府の責任重大 (Anti-Japan Movement and Treaty Revision: Cabinet's Responsibility Is Heavy).
- 5.16 (TN 5.16). Ed. “Ikizumareru tai Man seisaku: dakainan” 行詰まれる対満政策 打開難 (Policy Towards Manchuria at a Deadlock: Hard to Find a Way Out).
- 5.19 (TN 5.19). Ed. “Shina no jūdai kiki: sanminshugi no haki” 支那の重大危機 三民主義の破棄 (China's Grave Crisis: The Three Principles of the People Scrapped).
- 5.26. Ed. “Son Chūzan: Shina no kokuminteki saiten ni saishite” 孫中山 支那の国民的祭典に際して (Sun Zhongshan: On the Occasion of China's National Celebration).
- 5.30 (TN 5.30). Ed. “Hōten kanken no tai Ro kyōatsu: Harubin rinken jiken” 奉天官憲の対露強圧 ハルビン臨検事件 (Hard Measures Against Russia by Fengtian Authorities: The Police Raid Incident in Harbin).

- 6.14. Ed. "Ro-Shi kankei: 'kokkō danzetsu' no igi" 露支関係 「国交断絶」の意義 (Russia-China Relations: The Meaning of 'Severance of Diplomatic Relations').
- 6.22 (TN 6.21). Ed. "Waga tai Shi kan o ayabumu: haran to chōryū" わが対支観を危ぶむ 波瀾と潮流 (Doubting Our View of China: Troubled Waters and Tidal Currents).
- 6.25. Ed. "HanNichi undō o teishi seyo: jōyaku kōshō mae ni" 反日運動を停止せよ 条約交渉前に (Stop the Anti-Japan Movement Before the Treaty Negotiations!).
- 7.2. Ed. "Naikaku gakai ni itatta jijō: jirenma o ikan" 内閣瓦解に至った事情 ジレンマを如何 (Circumstances that Led to the Cabinet's Fall: How to Cope with a Dilemma).

## Other Publications

- Ariyama Teruo 有山輝雄 (2009). *Kindai Nihon no media to chiiki shakai* 近代日本のメディアと地域社会 (Modern Japan's Media and Local Society). Tokyo: Yoshikawa kōbunkan.
- Asahi shinbun (Asahi shinbun hanbai hyakunenshi henshū iinkai 朝日新聞販売百年史編集委員会 Editorial Committee of the One Hundred Year History of the Asahi Shinbun Sales) (ed.) (1979). *Asahi shinbun hanbai hyakunenshi (Ōsaka hen)* 朝日新聞販売百年史 (大阪編) (One Hundred Year History of the Asahi Shinbun Sales [Osaka Volume]). Osaka: Asahi shinbun Ōsaka honsha.
- Eguchi Keiichi 江口圭一 (1973). "Santō shuppei, 'Manshū jihen' o megutte" 山東出兵、「満州事変」 (On the Shandong Expedition and the 'Manchurian Incident'). Inoue Kiyoshi 井上清; Watanabe Tōru 渡部徹 (eds), *Taishō ki no kyūshinteki jiyūshugi: 'Tōyō keizai shinpō' o chūshin toshite* 大正期の急進的自由主義: 「東洋経済新報」を中心として (Radical Liberalism in the Taishō Period: The Case of the *Tōyō keizai shinpō*). Tokyo: Tōyō keizai shinpōsha, 353-92.
- Fujimura Ichirō 藤村一郎 (2013). *Yoshino Sakuzō no kokusai seiji ron: Mō hitotsu no tairiku seisaku* 吉野作造の国際政治論: もうひとつの大陸政策 (Yoshino Sakuzō's Views on International Politics: Another Continental Policy). Tokyo: Yūshisha.
- Gotō Takao 後藤孝夫 (1987). *Shingai kakumei kara Manshū jihen e: Ōsaka Asahi shinbun to kindai Chūgoku* 辛亥革命から満州事変へ: 大阪朝日新聞と近代中国 (From the Xinhai Revolution to the Manchurian Incident: The Ōsaka Asahi shinbun and Modern China). Tokyo: Misuzu shobō.
- Hattori Ryūji 服部龍二 (2001). *Higashi Ajia kokusai kankyō no hendō to Nihon gaikō, 1918-1931* 東アジア国際環境の変動と日本外交 1918-1931 (Changes in the International Environment of East Asia and Japan's Foreign Policy, 1918-1931). Tokyo: Yūhikaku.
- Huffman, J.L. (1997). *Creating a Public: People and Press in Meiji Japan*. Honolulu: University of Hawai'i Press.
- Iriye, A. (1973). *After Imperialism: The Search for a New Order in the Far East, 1921-1931*. New York: Atheneum.
- Kasza, G.J. (1988). *The State and the Mass Media in Japan, 1918-1945*. Berkeley: University of California Press.

- Keiho kyoku 警保局 (Police Affairs Bureau) [1927] (1979). *Shinbun zasshisha tokuhi chōsa* 新聞雑誌社特秘調査 (Special Confidential Survey of Newspaper and Magazine Companies). Tokyo: Taishō shuppan.
- Kitano Gō 北野剛 (2017). “Senkanki no Nihon to Manshū: Tanaka naikakuki no Manshū seisaku no saikentō” 戦間期の日本と満洲—田中内閣期の満洲政策の再検討 (Interwar Japan and Manchuria: A Reexamination of the Manchuria Policy at the Time of the Tanaka Cabinet). Itō Shin'ya 伊藤信哉; Hagihara Minoru 萩原稔 (eds), *Kindai Nihon no taigai ninshiki* 近代日本の対外認識 (Perceiving the Outer World in Modern Japan), vol. 1. Tokyo: Sairyūsha, 195-225.
- Mainichi shinbun (Mainichi shinbun 130 nenshi kankō iinkai 毎日新聞 130 年史刊行委員会 Committee for the Publication of the Mainichi shinbun 130 Year History) (2002). *'Mainichi' no 3 seiki: shinbun ga mitsumeta gekiryū 130 nen* 「毎日」の3世紀—新聞が見つめた激流 130 年 (Three Centuries of the *Mainichi*: A Torrent of 130 Years in the Newspaper's Eyes). 3 vols. Tokyo: Mainichi shinbunsha.
- Masuda Hiroshi 増田弘 (2017). *Ishibashi Tanzan: Shisō wa ningen katsudō no konpon, dōryoku nari* 石橋湛山: 思想は人間活動の根本・動力なり (Ishibashi Tanzan: Thought is the Basis of Human Actions and Efforts). Kyoto: Mineruva shobō.
- Murai Ryōta 村井良太 (2014). *Seitō naikakusei no tenkai to hōkai, 1927-36 nen* 政党内閣制の展開と崩壊 一九二七～三六年 (The Development and Collapse of the Party Cabinet System, 1927-36). Tokyo: Yūhikaku.
- Nihon shinbun nenkan* 日本新聞年鑑 (Japan's Newspaper Yearbook) (1921-40). 19 vols. Tokyo: Shinbun kenkyūjo. Reprint: Nihon tosho sentā, 1985-86.
- Revelant, A. (2017). “Revolution Deconstructed: Chiang Kai-shek and the Northern Expedition in the Japanese Press, 1926-28”. De Giorgi, L.; Samarani, G. (eds), *Chiang Kai-shek and His Time: New Historical and Historiographical Perspectives*. Venezia: Edizioni Ca' Foscari, 127-70. <http://doi.org/10.14277/6969-126-3/SV-4-6>. Sinica venetiana 4.
- Revelant, A. (2018). “The Spectre of ‘Red China’: The Northern Expedition and Japanese Public Opinion, 1926-27”. Mayayo, A.; Rúa, J.M.; Segura, A. (eds), *Centenary of the Russian Revolution (1917-2017)*. Barcelona: Edicions de la Universitat de Barcelona, 455-65.
- Sasaki Takashi 佐々木隆 [1999] (2013). *Media to kenryoku* メディアと権力 (Media and Power). Tokyo: Chūō kōron shinsha.
- Satō Motoei 佐藤元英 (2009). *Shōwa shoki tai Chūgoku seisaku no kenkyū: Tanaka naikaku no tai ManMō seisaku* 昭和初期対中国政策の研究: 田中内閣の対滿蒙政策 (A Study of the China Policy in the Early Shōwa Period: The Manchuria-Mongolia Policy of the Tanaka Cabinet). Tokyo: Hara shobō.
- Shimada Daisuke 島田大輔 (2013). “HanShō-ha to ‘Ōsaka Mainichi shinbun’: chūgen taisen ni okeru Nihon shinbun no chūritsusei ni tsuite” 反蔣派と『大阪毎日新聞』: 中原大戦における日本新聞の中立性について (The Anti-Chiang Faction and the Ōsaka *Mainichi shinbun*: Concerning the Neutrality of Japanese Newspapers in the Central Plains War). Paper presented at the 78th meeting of the 20 seiki media kenkyūjo 20世紀メディア研究所 (The Institute of 20th Century Media), Tokyo.
- Shimada Daisuke 島田大輔 (2017). “Shinbun kisha ni okeru kokumin kakumei ninshiki to tai ManMō kyōkōron no keisei: Tōkyō Asahi shinbun Ōnishi Itsuki no Manshū jihen ni itaru tenkai” 新聞記者における国民革命認識と対滿蒙強硬論の形成: 東京朝日新聞大西斎の満洲事変に至る転回 (The Percep-

- tion of the National Revolution and the Genesis of a Hardline View on Manchuria-Mongolia in a Newspaper Journalist: The Turn of Tōkyō Asahi shinbun's Ōnishi Itsuki up to the Manchurian Incident). *Rekishi hyōron* 歴史評論 (Historical Journal), 811, 57-70.
- Shimada Daisuke 島田大輔 (2018). "Aru Chūgoku senmon kisha no tanjō: 1910-20 nendai no Ōta Unosuke no Chūgoku keiken to Chūgoku ninshiki" ある中国専門記者の誕生: 一九一〇~二〇年代の太田宇之助の中国経験と中国認識 (The Birth of a Journalist Specialising in Chinese Affairs: Ōta Unosuke's Experience of China and Perception of China in the 1910s-20s). *Mediashi kenkyū* メディア史研究 (Media History Research), 44, 54-76.
- Tamai Kiyoshi kenkyūkai (Keiō gijuku daigaku hōgakubu seiji gakka Tamai Kiyoshi kenkyūkai 慶應義塾大学法学部政治学科玉井清研究会 (Tamai Kiyoshi Research Group, Political Science Department, Faculty of Law, Keio University) (2009). *Chō Sakurin bakusatsu jiken to Nihon no masu media* 張作霖爆殺事件と日本のマスメディア (The Incident of Zhang Zuolin's Killing by Bombing and Japan's Mass Media). Vol. 15, *Kindai Nihon seiji shiryō* 近代日本政治資料 (Documents on Modern Japan's Politics). Tokyo: Tamai Kiyoshi kenkyūkai.
- Tamai Kiyoshi kenkyūkai (Keiō gijuku daigaku hōgakubu seiji gakka Tamai Kiyoshi kenkyūkai 慶應義塾大学法学部政治学科玉井清研究会 [Tamai Kiyoshi Research Group, Political Science Department, Faculty of Law, Keio University]) (2015). *Sainan jiken to Nihon no masu media* 済南事件と日本のマスメディア (The Jinan Incident and Japan's Mass Media). Vol. 20, *Kindai Nihon seiji shiryō* 近代日本政治資料 (Documents on Modern Japan's Politics). Tokyo: Tamai Kiyoshi kenkyūkai.
- Usui Katsumi 臼井勝美 (1971). *Nicchū gaikōshi: hokubatsu no jidai* 日中外交史—北伐の時代 (A History of Japan-China Relations: The Age of the Northern Expedition). Tokyo: Hanawa shobō.
- Usui Katsumi 臼井勝美 (1998). *Nihon gaikōshi kenkyū: Shōwa zenki* 日本外交史研究—昭和前期 (A Study on the History of Japan's Foreign Policy: The First Part of Shōwa). Tokyo: Yoshikawa kōbunkan.
- Yamamoto Taketoshi 山本武利 (1981). *Kindai Nihon no shinbun dokushasō* 近代日本の新聞読者層 (Newspaper Readership in Modern Japan). Tokyo: Hōsei daigaku shuppan kyoku.

**The Historian's Gaze**

Essays on Modern and Contemporary China  
in Honour of Guido Samarani

edited by Laura De Giorgi and Sofia Graziani

# Forging the Nation Through Friendship: Nationalist China's Propaganda on Wounded Soldiers in the Early 1940s

Laura De Giorgi

Università Ca' Foscari Venezia, Italia

**Abstract** This essay offers a reflection on the discourse concerning the relief work for wounded soldiers in China during the War of Resistance against Japanese Aggression as presented on the pages of the magazine *The Friends of the Wounded Soldiers*. As the mouthpiece for one of the most important associations connected to the New Life Movement during the war, the journal's articles offer insights into the articulation of martial citizenship as a core notion in the process of nation-building in those years, showing how the relief work was conceived as a way of promoting a stronger engagement – articulated in terms of friendship – of the educated élite towards society and the state.

**Keywords** China's war against Japan. War relief. Propaganda. Wounded soldiers. New Life Movement.

**Summary** 1 The Challenges of Relief for Military Victims of War. – 2 Building a Martial Citizenship Through Friendship. – 3 Conclusions.

In the last twenty years, the historical significance of the War of Resistance against Japanese Aggression (1937-45) has been widely recognised from both contemporary Chinese and global perspectives. An increasingly rich scholarship has not only focussed on reassessing the military history of those dramatic years (e.g. Peattie, Drea, Van de Ven 2010); it has also investigated the impact of the war on the processes of state-building, on the one hand, and on in-



Edizioni  
Ca' Foscari

**Sinica venetiana 10**

e-ISSN 2610-9042 | ISSN 2610-9654

ISBN [ebook] 978-88-6969-723-4 | ISBN [print] 978-88-6969-724-1

**Peer review | Open access**

Submitted 2023-03-07 | Accepted 2023-04-03 | Published 2023-10-11

© 2023 De Giorgi | © 4.0

DOI 10.30687/978-88-6969-723-4/007

dividual and collective values and attitudes, everyday life, and political culture, on the other (e.g. Lary 2010; Mitter 2013; Lu 2015). Indeed, as the first modern mass conflict experienced by the Chinese people, the war was a foundational moment in the making of modern China from several perspectives, not least because it contributed to shaping and spreading a new imaginary of the Chinese national community and society.

This imaginary was produced through the engagement of Chinese intellectual and political élites at both the national and local levels in an unprecedented – at least in terms of scale – effort of mass propaganda and popular education as part of an attempt to make sense of the conflict and mobilise the population in support of the military resistance (Hung 1994). One of the outcomes of this effort was to blur the divide between civilians and soldiers in a grander vision of a united and disciplined society, whose citizens were keen to pour their efforts into the salvation and progress of their motherland. This was a vision shaped by nationalist values, whose origins predated the war and can be traced back to the impact of colonial discourse on the self-perception of Chinese élites at the turn of the twentieth century, when the perceived lack of modern martial values – physical strength, self-discipline, sobriety, self-sacrifice, endurance, resilience and solidarity beyond the circle of family relations – was identified as one of the main reasons for China's political weakness in international society.

Unsurprisingly, this mass pedagogy to promote modern nationalism paid specific attention to the making of the modern soldier as a model for a new citizenship (Xu 2019). Particularly after the abolition of imperial examinations in 1905, this was matched by the recognition of modern military education as a valuable pathway to a job and even a career in civil power, as a consequence of the increasing militarisation of political life in the years of the Republican revolution.

Nevertheless, this did not mean that the social and cultural position of rank-and-file soldiers changed in a radical way. Throughout the Republican era (1912-49), the violence and insecurity experienced by Chinese society due to the ongoing wars between the armies of the warlords and between the Guomindang and the Communists, contributed to maintaining the social perception of soldiers as a symbol not of the strength of a modern Chinese state but of the divisiveness and chaos of the domestic Chinese political landscape. It was only in 1934, with the launch of the New Life Movement, that Chiang Kai-shek envisioned a stronger militarisation of Chinese society in cultural terms as an important step in transforming China into a modern nation-state.

The broad agenda of the New Life Movement was to discipline Chinese society, both élites and the common people, in order to shape a new ideal of modern citizenship inspired by martial values (Ferlanti



2010; Culp 2007; Bodenhorn 2002; Clinton 2017). This movement hinted at a transformation of the image of soldiers, which accelerated during the total conflict against Japan, when Nationalist propaganda offered a representation of China as a heroic and united nation that was the victim of the violence and brutality of the occupiers and ready to resist occupation at any cost. In this representation, wounded soldiers played a pivotal role. Over their maimed and suffering bodies and minds, a discourse on the destiny of China as the victim of the occupiers' violence and on its heroic resistance was intertwined with the symbolic construction of a new national community shaped by martial values and social cohesion. To explore this facet of Chinese war propaganda, this essay offers a brief analysis of the discourse on the care of wounded soldiers developed by the monthly magazine *Friends of the Wounded Soldiers* (*Shangbing zhi you yuekan* 伤兵之友月刊), which, under the aegis of the Nationalist Party, was published in Nationalist China from the early 1940s as the mouthpiece for one of the most important associations for war relief.

## 1 The Challenges of Relief for Military Victims of War

Wounded soldiers represented just one of the dramatic tolls paid by China in the War of Resistance. According to recent Chinese statistics, the total military casualties during the war amounted to more than eight million people, of whom 2,240,000 were considered wounded (An 2018). This number is probably an underestimate, as most of the wounded soldiers died quickly, before they were able to receive proper treatment.

Despite the lack of definite numbers, it is evident that the need to cope with soldiers requiring medical and social care because they were wounded in battle was a great challenge for the Nationalist government, from both a military and political perspective. In modern states and in modern warfare, soldiers are not considered expendable, as their training makes them valuable assets for war. There is certainly a consideration of cost, as the need to instruct and train a soldier makes it important to preserve that valuable human resource. In China, as national conscription was not applied, the problem of recruiting soldiers was quite significant. Even with its scarcity of resources, the Nationalist state could not really afford to lose credibility by abandoning the wounded to their sad destiny, despite the negative opinion of Westerners about the Chinese capacity and perhaps will to help the wounded (Powell 2015).

One of the challenges was to develop military medicine. The capacity to offer medical services at the frontline was a huge but fundamental task for the Nationalists (Watt 2013). During the first year of the war, the lack of personnel and means to evacuate the wounded

from the battlefield and to cure them was evident. However, foreign observers often ascribed the problem not only to poor organisation and lack of material means, but also to the indifference of the army officers towards the ordinary soldiers (Watt 2013, 119). In the course of time, the problem was somehow properly addressed. Although a systematic approach was missing, several military commanders became aware of the need to provide healthcare to the wounded within the military structure.

The improvement in healthcare services for the wounded was essentially due to the Chinese Red Cross Medical Relief Corps, led by a Chinese medical élite trained abroad and materially supported by the overseas Chinese (Mamlok 2018). The treatment of wounded soldiers was one of the main areas where civilians and intellectuals were engaged in the military side of the war. In his study, Watt emphasises that the Chinese Red Cross “provided a way to overcome the resistance of educated youth to war work and bring their patriotism and skills to the aid of front-line soldiers” (Watt 2013, 120). Thanks to the schools operated by the leading Red Cross doctors (mostly overseas Chinese) under the aegis of the national government and ministries, new personnel were educated to serve in military hospitals. Moreover, the Nationalist government mobilised medicine students to serve in the army hospitals: in 1941, almost eighty per cent of the students in the field were conscripted to work in government-run hospitals and healthcare centres (Chang, Myers 1994, 169).

Under the control of the Nationalist government, the assistance for wounded soldiers was conceived of as an arena for a stronger interaction between the military and civilians. The activities of the Chinese Red Cross and the government institutions for relief were not only addressed to the military but also to civilians, especially as these activities involved preventive medicine at both the battlefield and the rear front. This was because one of the main challenges of wartime was the control and reduction of the health risks connected to epidemic diseases, which was also addressed by developing logistics and production capacity in biomedicine (Brazelton 2019).

However, civilians were not only the beneficiaries of the new emerging organisation of military medicine. They were also a strategic resource to make the system work. Particularly after 1938, when the military hospitals were mainly located at the rear front and distant from the battle line, the tasks of assisting the wounded on the spot and carrying them to the hospital often depended on the cooperation of the civil population, as in the contribution of local peasants as stretcher bearers.

As war medicine was not exclusively a military affair but also conceived of in terms of the public interest of the populace at large, war propaganda made the problem of assisting wounded soldiers a discursive space for promoting a new social and cultural cohesion and

Nationalist values crossing the divide between soldiers and civilians. The cure of the injured in the battlefield was represented as evidence of the coming into existence of a new China, whose citizens were not only all keen to support one another in the name of a solidarity imbued with martial and heroic values, but also ready to recognise the centrality of these values to their nation's identity.

In symbolic terms, the Japanese invasion of China implied a change in the status of military personnel, who were accorded the halo of heroes in the defence of the motherland. As Diana Lary writes, this image of soldiers was mainly the "product of mass anger" caused by the Japanese violent occupation, and it was boosted by a huge propaganda effort by the Nationalists (Lary 2014, 240). At the same time, the central role attributed to soldiers in China's self-representation also reflected the enactment of an ideal of 'martial citizenship' (Diamant 2010) in which the willingness to offer flesh and blood fighting for the sake of the nation was worthy of greater respect than other forms of patriotism. Historically, in this notion of citizenship, participation in war enabled individuals and groups, who until that moment had remained marginal in the national imagination because of lower educational or social status, to overcome the implicit limitations and obstacles to full recognition as citizens.

However, if participation as fighting soldiers in war could ideally open the pathway to a full recognition of soldiers' status as citizens, this acknowledgement has to be measured along time. Admiration and respect may not be destined to last long when soldiers are back in civil life, especially if they are disabled or suffering in a situation characterised by a scarcity of material resources. In this sense, as Neil Diamant argues, popular attitudes towards veterans and ex-soldiers who embodied the human sacrifice for the national community should be considered a standard for gauging the depth and solidity of national feelings and patriotism in a community (Diamant 2010). The role of the state in this, however, cannot be dismissed. In wartime China, the Nationalists were willing to connect the military effort against the invaders to their own project of state- and nation-building, and they were aware of the symbolic importance that assistance to wounded soldiers had in legitimising their government as well as in shaping a national community according to their vision. If the wounded soldiers were abandoned or forgotten, this would have suggested that their sacrifice for the nation was not worthy even in the eyes of the government and army leaders. Worse, it would have clearly shown that the new Chinese nation, as a community of citizens ready to sacrifice themselves for the good of the collective, did not exist, weakening all the propaganda efforts to drive collective resistance.

The name used to define wounded soldiers in Nationalist public discourse highlights the critical importance they had for propaganda. Defined as *rongyu junren* 荣誉军人 (honorary soldiers), they were

presented as the embodiment of the glory and honour of self-sacrifice for the nation, an honorific title that downplayed or even hid the physical and social misery of their actual status.

The Nationalist state's endorsement of the relief activities addressed to the 'honorary soldiers' is shown by the role played by high-ranking personalities and officers, such as the Chinese first lady Song Mei-ling 宋美齡, and by its connection with the New Life Movement (Cui 2008). As Song herself emphasised in 1944 (Song 1941, quoted in Lawrence 2004, 62), the care for wounded soldiers was directly connected to the spirit of the New Life Movement and its promotor Chiang Kai-shek 蔣介石. In this speech, Song Mei-ling mentioned the Wounded Soldier League, whose role was to distribute Chiang Kai-shek's money to wounded officers and soldiers, as an example of the spirit expected to imbue the Chinese people's resistance against the Japanese.

On the same occasion, Song mentioned the Association of Friends of the Wounded Soldier, one of the most active state-connected organisations in support of those injured in war. This association was founded after the great fire of Changsha in 1938 thanks to the initiative of some Nationalist intellectuals and Western missionaries (*Shangbing zhi you yuekan* [hereafter *SBZY*] 1942), but it was officially established later, in 1940, on the occasion of the sixth anniversary of the New Life Movement. Its political and even institutional connections were enhanced by the choice of General Huang Renlin 黃仁霖 as Director. The formal directorate included all the most important leaders and personalities of the Nationalist Party, which publicly supported the association's goals.

The association was organised as a bureaucratic structure, as were several others of the New Life Movement's organisations. Service teams were established in the provinces and main cities, especially in the Southwestern provinces, such as Hunan, Hubei and Sichuan, where most of the activities in support of wounded soldiers arriving from the battlefield took place. Its activities included the opening of special guest-houses for wounded soldiers and the organisation of assistance in hospitals, providing the wounded with daily necessities, such as towels, toothbrushes, shoes, and fans (Jiang 2011). Moreover, volunteers were invited to help soldiers with their everyday hygiene and to engage in education and entertainment activities for those being assisted. According to Song Mei-ling, the association's

very name caught the imagination and heart of Chinese patriots. Figuring on the basis of 100,000 wounded soldiers in various army hospitals, the movement aimed at soliciting 100,000 'friends'. The goal of the campaign was to provide a 'friend' for each wounded soldier. To become a 'friend' one paid a friendship fee of \$ 1 or more, and pledged service to the wounded. By the end of the

month, the campaign had brought in no less than 654,774 'friends' with a total of \$ 1,332,505.74 in cash, which was 553 per cent over the top. (Song 1941, quoted in Lawrence 2004, 62)

As this quotation shows, the involvement of civilians in support of wounded soldiers primarily had a financial reason. Collecting funds served to relieve the state from the huge cost of the care for wounded soldiers. After the outbreak of the war, in October 1937, the Nationalist government had established a Central office for the management of wounded soldiers (*Zhongyang shangbing guanli chu* 中央伤兵管理处), later renamed the Central office for the honorary soldiers (*Rongyu junren guanli chu* 荣誉军人总管理处). This office was responsible for the organisation and management of several structures, such as shelters and camps (Wang 2013). The financial burden was significant, and the mobilisation of economic support from civil society was deemed essential.

In 1940, the same economic considerations were at the basis for the publication of an "Outline for a Plan of services for the honorary soldiers" (*Rongyu junren fuwu jihua gangyao* 荣誉军人服务计划纲要), whose goal was to promote the return to work of wounded soldiers, with the idea of making them self-sufficient and not reliant on state support (Wang 2013). In this plan too, the role of civilians was strategic in terms of supporting the education and training of the wounded and, where possible, facilitating their employment in factories, workshops and farms.

Financial needs, however, were not the only reason to engage civilians in this effort. The connection of the assistance for wounded soldiers to the New Life Movement implied that it was conceived and practised as a contribution to the process of nation-building (Gou 2008). The activities designed for this goal had to promote values and behaviours consistent with Chiang Kai-shek's vision of a disciplined and militarised society under the umbrella of the state. This was not only a medical or social task, but also a way of building a modern collective citizenship based on a new notion of 'friendship' as the glue for a new national community.

## 2 Building a Martial Citizenship Through Friendship

In Chinese culture, the notion of being a ‘friend’ (*you* 友) is complex, especially in Confucian philosophy, referring to the most important human relationship outside family bonds and state obligations (Wang 2017). Seen as a human connection that originates not through birth but as a consequence of circumstances and the outcome of personal choices and affinities, the idea of friendship usually includes an emotional bond as well as a utilitarian scope. True friends are expected to offer solidarity in material terms but also to practise mutual respect and to express affection; moreover, their role is not really seen as an alternative to or as countering other social institutions, such as the family or state, but rather as supporting the full realisation of the social role of the individual within a proper network of relations.

In modern China’s patriotic propaganda and public discourse, the notion of friendship hinted at promoting a feeling of reciprocal obligation towards individuals to whom one was not tied through family relationships. This obligation had to be fulfilled in the name of a shared and superior ideal of the nation and modern citizenship beyond the traditional family and the *natural* bonds of the clan. In this sense, friendship may hint at an idea of a national community rooted not in the metaphorical extension of *blood* but in the adherence to a shared set of values and commonality of intents.

The meaning of friendship as something to be nourished and practised by choice and virtue – expressed not only in moral and emotional terms, but also in material terms and ultimately directed towards supporting the wounded to fully achieve their role as active citizens – is clearly articulated in the list of “The Vows of the ‘Friends of the Wounded Soldiers’” (*Shangbing zhi you’ xintiao* ‘伤兵之友’ 信条) published in the war magazine *Huangpu jikan* in 1943 (*Huangpu jikan* 1943, 34).

The vows of the ‘Friends of the Wounded Soldiers’:

1. I will respect the wounded soldiers.
2. I will empathise with the wounded soldiers.
3. I will give money to the wounded soldiers.
4. I will pour my energy into supporting the wounded soldiers.
5. I will serve the wounded soldiers.
6. I will support the families of the wounded soldiers.
7. I will actively change the negative views of life of the wounded soldiers.
8. I will be a friend of the wounded soldiers forever.

As this text demonstrates, showing friendship towards soldiers who had been injured and maimed required emotional and practical engagement, while suggesting that a ‘friend’ had to help the receivers of friendship to remain full members of the national community. Re-

lief for the wounded was not only a practical need for sustaining the resistance efforts; it was also a self-educating practice addressed at forging a new community of values.

This articulation of friendship was rhetorically central to the narratives developed in the magazine of the Association of Friends of the Wounded Soldiers, *Shangbing zhi you*. This magazine was a monthly or half-monthly publication mainly addressed to the activists of the association. Activists were supposed to be mainly educated youth, such as students or teachers (Gou 2006), and the magazine was an instrument to help the organisation of work for supporting the wounded, especially in hospitals. At the same time, it represented a site where the educated élite articulated a public discourse regarding soldiers' place in society and their relationship with them.

The fact that the association was conceived as a place for interaction between soldiers and civilians was explicitly affirmed by Chiang Jingguo 蒋经国, who in a talk at the assembly of the association, later published in the magazine in 1940, claimed that the ultimate goal of the association was to unite soldiers and the people by recognising the wounded soldiers as honoured members of society and models of patriotism (*SBZY* 2, 1940). As another article emphasises (*SBZY* 14, 1942), differently from the past, modern war was not for the sake of kings but for the sake of the people of the nation: wounded soldiers were a national problem, and its solution required the participation of everyone, whether through financial aid or voluntary personal effort.

In the magazine's pages, the task of caring for wounded soldiers was detailed in several practical activities. The 'friends of the wounded soldiers' had to provide them with medicine, food and clothes, as well as taking care of their personal hygiene. Contemporary descriptions of the state of soldiers in hospitals make clear that the sanitary conditions were often dramatically bad (Watt 2013); consequently, the promotion of personal modern hygiene was of crucial importance during the war. The magazine offered several educational materials to be used to instruct activists and soldiers in modern hygienic rules for hospitals. But hygiene also included aesthetic standards, as it meant helping soldiers maintain a tidy and clean aspect, shaving their hair or cutting their nails. From this perspective, the practice of hygiene for the soldiers was connected to the goals of the New Life Movement, whose idea of national modernity reflected the appropriation of the colonial discourse on Chinese backwardness.

The will and capacity to carry on all these tasks was a manifestation of 'friendship' based on the relationship between the wounded and the caregivers. Soldiers had been eager to sacrifice their health and body for the sake of the people of the nation, just as good friends are ready to fight for the defence of one another. Now, as loyal friends, civilians should respect, honour and take care of the wounded who had placed their lives at risk (*SBZY* 14, 1942).

If fellow citizens were supposed to behave as good friends whose reciprocal relations were not opportunistic but based on loyalty and moral obligations, there should be no hierarchy in this relationship, and both parties were considered equal. Nevertheless, the notion of 'friendship' did not totally exclude an attitude, as friends were thought to be able to give advice and support in order to make the receivers of their attention fully achieve their potential social roles. Thus, the general discourse about soldiers was also shaped by a paternalistic attitude that implicitly hinted at the great divide existing between the educated élite and the wounded soldiers.

In this respect, it is worth noting that one of the main activities required from the members of the association was to educate the soldiers, as education was a prerequisite for modern citizenship. Wounded soldiers were expected to be honoured and respected by everyone, but embodying the heroism of the Chinese nation, they also had to constitute a model for all society because of their courage, patriotism and higher sense of morality (*SBZY* 13, 1941). As several articles in the magazine suggest, the gap between this ideal and the reality was rather huge. The magazine prompted activists to acknowledge and address the problem that wounded soldiers' attitudes and behaviours were often distant from the ideal image that the war propaganda wanted to offer. Coming from poor villages, often not educated, shocked by the war and still tied to the superstitions and habits of the rural world, it was not an easy task to make them behave in ways that lived up to the standards promoted by the propaganda. The acknowledgment that soldiers could not actually be the purest embodiment of martial virtues might somehow weaken both their potential value for patriotic education and the likelihood that the magazine's audience would emotionally identify the soldiers as symbols of a new and modern nation. This also hinted at a class division that war could not conceal. Whereas ordinary soldiers had mostly a rural background, relief for the wounded was mainly conceived as a way in which urban and educated élites could be directly involved in the war. Offering more than material support, friends were actually invited to educate the soldiers. Several comments in the magazine pointed out how the low educational level and the rural background of most of the Chinese soldiers made this goal quite challenging (*SBZY* 3, 1940). Honorary soldiers were peasants who did not know what war they were fighting, nor did they know anything about the Three Principles of the People of Sun Yat-sen. They were like children, always complaining, pretending and quarrelling about trivial things. Maybe they were loyal to their battalion and commanders, but they were not capable of conceiving of China as a nation or of their role and duties as fighting citizens.

Interestingly, the war propaganda's discourse identified the violence of the conflict as the main cause of the soldiers' inferior and backward status. Caregivers and supportive readers had to be aware



that the injuries suffered by the soldiers were not only in their bodies but also in their psyches. The violence of the Japanese was a trauma that 'loyal friends' (i.e. the association's members) were called to consider and to heal. It was this trauma that impeded the soldiers from being the honoured members of society and models of heroic citizenship that they were expected to be. The experience of the war had first made many injured soldiers undisciplined and not respectful of authority; second, they now often indulged in vices, such as drinking, betting or going to prostitutes; third, they were often depressed and apathetic (*SBZY* 3, 1940). They not only had to be cured from the physical consequences of their injuries; they also required help in developing a better awareness of their roles and in comprehending the true significance of their sacrifices. The propaganda argument that the violence inflicted on the Chinese people and soldiers by the Japanese was the main cause of the honorary soldiers' incapacity to live up to the moral and physical standards required of them by modern citizenship, aimed at rejecting the idea that the Chinese common people were incapable of being truly modern as well as at emphasising the authority of the educated élite in popular education.

In their magazine, the 'friends' suggested that the education of wounded soldiers was intended to 'militarise' their lives once more, as their suffering and the shock of the war had driven them to forget that they were soldiers and heroes. Reflecting the New Life Movement's goals, several articles recommend that activists organise military discipline for the wounded, forcing them to take care of their bodies and health and to respect hygiene rules and training practices. Moreover, the wounded had to be educated and entertained in a healthy manner, which meant being exposed to intensive nationalistic and ideological propaganda through the means of songs and tales. Basic slogans and notions were duly reported on in the magazine's pages: they should learn first that they were soldiers and that their duty was to defend the country and protect the people; second, that their leader was Chiang Kai-shek; and third, that their country was the Republic of China (*SBZY* 3, 1940). However, in detailing the activities and educational content that had to be addressed to the soldiers, the magazine framed the relief addressed to the wounded within Nationalist China's broader hegemonic educational and propaganda enterprise. According to the New Life Movement's values, civilians and soldiers alike all had to be educated in order to become disciplined citizens, abiding by the same set of martial virtues - spirit of sacrifice and loyalty to the leader and the state -, and obeying the collective interest. However, those who really embodied the new social and cultural values of the nation were the educated friends rather than the poor and rural 'honorary soldiers'. From this perspective, the war relief work under the aegis of the state highlighted the project of a militarised citizenship in service of the nation in which the

suffering and maimed bodies and minds of wounded soldiers were just the battlefield for the Nationalists' attempt to reshape and engage Chinese educated élites' attitudes towards the state.

### 3 Conclusions

During the War of Resistance against Japanese Aggression from 1937 to 1945, Chinese Nationalist propaganda worked to produce a new imaginary of modern China, centred on the emergence of a national community that was forged by the war, inspired by martial and heroic values and characterised by self-discipline and solidarity. In this endeavour, the distinction between soldiers and civilians was blurred, reflecting the centrality assumed by the notion of 'martial citizenship', whose distinctive trait was the willingness to serve the nation in the first person and to contribute to the resistance efforts under the aegis of the state. This was a vision that predated the war, as it was consistent with the goals of the New Life Movement, whose activities from 1937 onwards were increasingly connected to the mobilisation of civilians in support of the state and the army.

The relief work addressed to the wounded soldiers represented an important field for achieving this goal. On the one hand, this was because the Nationalist government was quite aware that the contribution of the educated and affluent class was economically and culturally necessary to support the state's relief efforts; on the other hand, this relief work represented a symbolic point of conjunction between the military and civil life. Wounded soldiers were still soldiers, and they were called to embody the Chinese people's capacity to sacrifice themselves for the sake of national salvation. Nevertheless, as they were unable to go back to the front, they were also close to the civilians as non-combatants; worse, they were weak and fragile persons in need of help in a time of scarce resources, deprived of the support of their own families and communities.

As a reading of the magazine *Friends of the Wounded Soldiers* suggests, the duty of solidarity between wounded soldiers and civilians was articulated by Nationalist propaganda in terms of 'friendship', hinting at a relationship between the caregiver and the assisted that connoted a shared experience, emotional bonds and the duty to offer material support. Emphasising friendship, the state aimed at forging a sense of reciprocal obligations among strangers, reflecting how the war was seen at the same time as a disruption of existing social and familiar networks and as the opportunity to redesign a new society based on the Nationalists' vision of a militarised modernity.

However, it is also worth noting how the same narratives suggest that the call to friendship could not really aim at crossing social and cultural boundaries. The work in support of the wounded soldiers

was certainly a reflection of the attempt to give the uneducated rural population, which was the bulk of the army, full recognition as worthy and honoured members of the new national community. However, above all, it was a way to shape élites' attitudes towards the war, educate them regarding their responsibility for the state's goals and co-opt them into the New Life Movement.

## Bibliography

- An, Z. (2018). "The Historical Contribution and Loss of China in the War Against the Japanese Aggression". *Global Media Journal*, 16-31.
- Bodenhorn, T. (ed.) (2002). *Defining Modernity: Guomindang Rhetorics of a New China, 1920-1970*. Ann Arbor: Center for Chinese Studies; University of Michigan.
- Brazelton, M. (2019). "Engineering Health: Technologies of Immunization in China's Wartime Hinterland, 1937-45". *Technology and Culture*, 60(2), 409-37.
- Chang, S.H.; Myers, R.H. (eds) (1994). *The Storm Clouds Clear Over China: The Memoir of Ch'en Li-Fu, 1900-1993*. Stanford: Hoover Institution Press.
- Clinton, M. (2017). *Revolutionary Nativism: Fascism and Culture in China, 1925-1937*. Durham: Duke University Press.
- Cui Jierong 崔节荣 (2008). "Song Meiling yu kangzhan shijian de shangbing jiu-zhu" 宋美龄与抗战期间的伤兵救助 (Song Meiglin and the Relief to the Wounded Soldiers During the War of Resistance). *Shixue yuekan zazhi* 史学月刊杂志, 6, 133-6.
- Culp, R. (2007). *Articulating Citizenship: Civic Education and Student Politics in Southeastern China, 1912-1940*. Cambridge: Harvard University Press.
- Diamant, N.J. (2010). *Embattled Glory: Veterans, Military Families and the Politics of Patriotism in China, 1949-2007*. New York: Rowman & Littlefield.
- Ferlanti, F. (2010). "The New Life Movement in Jiangxi Province, 1934-1938". *Modern Asian Studies*, 44(5), 961-1000.
- Gou Xingchao 苟兴朝 (2006). "Kangzhan shiqi Chengdu de 'Shangbing zhi you' yundong" 抗战时期成都的 '伤兵之友' 运动 (The Activities of the 'Friends of the Wounded Soldiers' in Chengdu During the Resistance War). *Wenshi zazhi* 西南交通大学学报, 3.
- Gou Xingchao 苟兴朝 (2008). "Lun Xinwen metidi zai 'Shangbing zhi you' yundong zhongde zuoyong" 论新闻媒体在 '伤兵之友' 运动中的作用 (On the Role of the News Media in the 'Friends of the Wounded' Movement). *Xinan jiaotong daxue xuebao*, 9(2), 63-7.
- Huangpu jikan 黄埔季刊 (1943). "'Shangbing zhi you' xintiao" '伤兵之友' 信条 (The Wows of the 'Friends of the Wounded Soldiers'). *Huangpu jikan*, 3(1), 4.
- Hung, C. (1994). *War and Popular Culture: Resistance in Modern China, 1937-1945*. Berkeley: University of California Press.
- Jiang Yinchun 姜迎春 (2011). "You jiuxu dao baozhang: kangzhan shiqi mingguo zhengfu de zhengcan junren de fuwuxing fuxu tanxi - Yu guotonggu rongjun jiaoyangyuan wei zhongxin" 由救恤到保障: 抗战时期国民政府的伤残军人的服务型抚恤探析 - 以国统区荣军教养院为中心 (From Relief to Guarantee: An Analysis of Service-Type Pensions for Disabled Servicemen of the National Government During the Anti-Japanese War - The Case of the Invalids Recreation Centres in the Areas Under State Control). *Minguo dang'an* 民国档案, 1, 111-17.

- Lary, D. (2010). *The Chinese People at War: Human Suffering and Social Change, 1937-1945*. Cambridge: Cambridge University Press, 310-24.
- Lary, D. (2014). "The Military Ascendant: The Ascendancy of the Chinese Military During the Resistance War, 1937-1945 (And Afterwards)". Kai, F. (ed.), *Civil-Military Relations in Chinese History: From Ancient China to Communist Takeover*. New York: Routledge.
- Mamluk, R. (2018). *The International Medical Relief Corps in Wartime China, 1937-1945*. Jefferson: McFarland & Co.
- Mitter, R. (2013). *Forgotten Ally: China's World War II, 1937-1945*. New York: Houghton Mifflin Harcourt.
- Peattie, M.; Drea, E.; Van de Ven, H. (eds) (2010). *The Battle for China: Essays on the Military History of the Sino-Japanese War of 1937-1945*. Stanford: Stanford University Press.
- Powell, L.S. (2015). *A Surgeon in Wartime China*. Kansas City: University of Kansas Press.
- Shangbing zhi you yuekan* 伤兵之友月刊 (Friends of the Wounded Soldier Monthly Review) (1940-1942). Chongqing: Shangbing zhi you 伤兵之友 (Association of Friends of the Wounded Soldiers).
- Song Mei-ling 宋美龄 [Madame Chiang Kai-shek] [1941] (2004). "China Shall Rise Again". Lawrence, A. (ed.), *China Since 1919: Revolution and Reform: A Sourcebook*. London; New York: Routledge, 62.
- Wang An 王安 (2013). "Zhiye chongjian: Minguo zhenghy shiqi kanzhan shangcan junren zhiye - Yi 'Can bu fei yuekan' we zhongxin" 职业重建: 国民政府时期抗战伤残军人的就业 - 以 '残不废月刊' 为中心 (Professional Reconstruction: The Employment of Disabled Soldiers of the Anti-Japanese War During the National Government Period - A Study of the *Disabled Monthly*). *Hubei shifan xueyuan bao* 湖北师范学院学报, 33(1), 79-85.
- Wang P. (2017). "The Chinese Concept of Friendship: Confucian Ethics and the Literati Narratives of Pre-Modern China". Risseuw, C. (ed.), *Conceptualising Friendship in Time and Place*. Leiden; Boston: Brill, 25-58.
- Watt, J.R. (2013). *Saving Lives in Wartime China: How Medical Reformers Built Modern Healthcare Systems Amid Wars and Epidemics, 1928-1945*. Leiden: Brill.
- Xu, Y. (2019). *The Soldier Image and State-Building in Modern China, 1924-1945*. Lexington: University of Kentucky Press.

**The Historian's Gaze**

Essays on Modern and Contemporary China  
in Honour of Guido Samarani

edited by Laura De Giorgi and Sofia Graziani

# Towards a New Political Order: Re-Establishing the Youth League after the Sino-Japanese War (1946-49)

Sofia Graziani

Università degli Studi di Trento, Italia

**Abstract** Recent studies on the history of the Communist Youth League in China have complicated the image of a symbiotic relationship with the Communist Party, by shedding light on internal dynamics and rivalries that characterized the 1920s. Yet, the revival of the Youth League following the Sino-Japanese War has been almost completely ignored in the international literature. This essay examines the institutional and organisational development of the Youth League in the late 1940s, focusing on the Party's policy design and decision-making and showing how the process of re-establishing the Youth League as a distinct organization under the firm leadership of the Communist Party dates back to 1946, when the Party started discussing the revival of the organisation and adjusted the system so as to limit its development and accumulation of power, by considering previous mistakes and addressing issues regarding age limits, differentiation of work and leadership.

**Keywords** New Democratic Youth League. Ren Bishi. Youth organisations. Civil war. Chinese Communist Party. Communist Youth League.

**Summary** 1 Introduction. – 2 The Early Efforts Towards Establishing the New Democratic Youth League. – 3 The Experimental Set Up of New Youth Organisations in Communist-Controlled Areas. – 4 Conclusions.



**Sinica venetiana 10**

e-ISSN 2610-9042 | ISSN 2610-9654

ISBN [ebook] 978-88-6969-723-4 | ISBN [print] 978-88-6969-724-1

**Peer review | Open access**

Submitted 2022-07-26 | Accepted 2022-09-17 | Published 2023-10-11

© 2023 Graziani | © 4.0

DOI 10.30687/978-88-6969-723-4/008

## 1 Introduction

With the proclamation of the People's Republic of China (PRC) in 1949, the new Communist leadership faced a series of urgent economic, social and political issues. Among them were issues concerning the reconstruction of the political and institutional order based on a model that made the Party, the state and the army pillars of a new system that entrusted the Chinese Communist Party (CCP) with a leading role in the functioning of the regime. To attain this objective, 'mass organisations' (*qunzhong zuzhi* 群众组织) were created to function as 'transmission belts' between the CCP and different sectors of society, hold a monopoly on the representation of certain social groups and solicit participation in political life according to the principle of the 'mass line' (*qunzhong luxian* 群众路线) (Barnett 1951; Townsend 1969; see also Audin, Doyon 2019 on more recent developments in the functioning of mass organisations).

Youth thus became a target of specific mass organisations designed to mobilise the new generation in support of CCP objectives and to create loyal citizens dedicated to the 'new China'. The All-China Youth Federation was established as a united front organisation to serve as a national umbrella entity and included, among others, the All-China Students Federation and the Communist Youth League (CYL), which was named the New Democratic Youth League (*Xin minzhuzhuyi qingnian tuan* 新民主主义青年团, NDYL) from 1949 to 1957. The latter also played a key political role in the entire system by running the Young Pioneers, the organisation for children aged 9 to 15. Besides serving as a bridge linking the CCP with the nation's youth, the Youth League also served as a training ground for future CCP members and cadres at all levels of the Party and government apparatus.

Unlike other mass organisations, the CYL had and still has a unique position, being defined as the 'main assistant' (*zhushou* 助手) and 'reserve force' (*houbeijun* 后备军) of the CCP, two functions that were formally recognised in the League's 1953 Statute and later in the CCP's 1956 Constitution approved at the Eighth CCP National Congress (Graziani 2013). Therefore, it has been highly embedded in the political and bureaucratic system as a junior partner of the CCP. Its subordination in the political system and organisational 'juniority' has characterised its life in the following years up to the present day (Tsimonis 2021, on cadres training see Doyon 2023).

However, recent studies on the history of the CYL have begun to complicate the image of a symbiotic relationship with the CCP (Yi 2022; Mulready-Stone 2015; Graziani 2014; see also Stranaham 1998, 43-4). What emerges from scholarship is that, starting with the foundation of the CYL (then named Socialist Youth League) in 1920, there have been times when the League was at odds with its parent organisation, even competing with the CCP and aspiring to transform it-

self into a 'second party'. Rivalry between the Party and the Youth League characterised the revolutionary movement of the 1920s, revealing the complexities involved in importing the Komsomol model from Soviet Russia to China. In 1936, the CYL was disbanded and integrated into the National Salvation Movement, being replaced by anti-Japanese youth national salvation associations, which appealed to a broader group of young people. This decision reflected not only the political climate of the time but also the influence of external factors (i.e. changes in Comintern and Communist Youth International strategies). Furthermore, according to Tsai and Liao (2021, 1-2), "the need to strengthen the Party's leadership to deal with escalating tensions with Japan was used as an excuse to disband CYL". Similarly, Yi (2022, 142) points out that "seeking to end the continuing rivalry, the party used this opportunity to disband the Youth League and fundamentally reorganize its interaction with the young generation". The organisation was only formally re-established after the CCP came to power in 1949.

This essay examines the institutional and organisational developments regarding the CYL in the period between the end of the Sino-Japanese War and the establishment of the PRC, and explores the ways in which the CCP directed and subordinated youth organisations by moving from mass organizations with broad anti-Japanese appeal to increased party discipline. The essay shows that the process of re-establishing the CYL as a distinct organisation under the firm leadership of the CCP dates back to the year 1946, when the first debates about the revival of the organisation emerged and the CCP intentionally acted to limit the development and accumulation of power of the Youth League due to prior conflicts between the two organisations, addressing issues regarding age limit, differentiation of work and leadership.

Compared with the rich literature on the CCP history, there have been few studies on the CYL. Recently published works have examined the politics and internal complexities of the CYL in the 1920s and early 1930s; however, the revival of the Youth League following the Sino-Japanese War has so far been almost completely ignored in the international literature, if we exclude the work by Pringsheim (1962). This chapter builds on and further develops recent studies conducted on CCP-CYL relations in the pre-1949 period, focussing on the Party's Youth League policy design and decision-making at the leadership level (rather than on operations on the ground) from 1946 to 1949, drawing on a variety of available Chinese sources, including histories of the youth movement, CCP documents and the memories of former cadres, such as those of He Qijun, who was a member of the CCP Central Youth Work Committee at the time.

## 2 The Early Efforts Towards Establishing the New Democratic Youth League

The First National Congress of the NDYL was held in April 1949 and saw the participation of 364 delegates representing 190,000 members. Ren Bishi's report to the First National Congress (presented as Honorary President of the league) focussed on the following issues: 1) the need for political leadership of the CCP; 2) the need to unite and educate the new generations, including the children of intellectuals and other strata of the petty bourgeoisie showing progress in political awareness; and 3) the importance of working with students, as future experts for the economic construction of the country (*Zhongyang tuanxiao qingniantuan gongzuo jiaoyanshi* 1979, 111-20). The name chosen fully reflected the orientation of the CCP for what was foreshadowed to be an upcoming transitional phase characterised by an alliance of all revolutionary classes. The name was changed to CYL in 1957 at the Third National Congress, reflecting the new political orientations of the Communist leadership and, above all, Mao Zedong. In the early phase of the PRC, the political and organisational features of the Youth League were defined by an organisational structure mirroring that of the CCP, to which it was subordinate, based on the Soviet model of the Komsomol, whose Central School in Moscow was a destination for many young Chinese cadres at the time (*Gongqingtuan zhongyang qingyunshi gongzuo zhidao weiyuanhui* et al. 2003).

Yet, the First National Congress of the New Democratic Youth League came at the end of a process that began in the mid-1940s, following the failure of the negotiations between the Guomindang (GMD) and the CCP after the end of World War II. As stated above, the history of the CYL has its roots in the early years of Communist politics and the Chinese revolution, but the organisation was in fact reformed in 1936, when the new strategy of a "united front against fascism", as formulated by the Seventh World Congress of the Comintern in August 1935 and received by the Communist Youth International the following month, combined with the popular and student response to Japanese aggression in China (December 1935), causing the CCP to change its youth policy (Samarani 2003; Solieri 2003; Graziani 2014; Yin 1992). The Party decided to replace the CYL with broader anti-Japanese youth national salvation associations, open to all patriotic young people regardless of their ideological-political affiliation. Meanwhile, the National Liberation Vanguard (*Minzu Jiefang Xianfengdui* 民族解放先锋队) was officially established by students in Beijing and was soon turned by the CCP North China Bureau into a united front patriotic youth mass organisation (Li 2012, 145). In October 1937, a document issued by the CCP North China Bureau called for widening this organisation, soliciting youth par-



ticipation in resistance efforts (Gongqingtuan zhongyang qingyun-shi gongzuo zhidao weiyuanhui et al. 1995, 588). Its membership had grown rapidly since its establishment and by the outbreak of the Sino-Japanese War, units had emerged in many cities across China as well as abroad. In autumn 1938, the National Liberation Vanguard merged with national salvation youth associations in areas under Communist control, while it was disbanded in GMD-controlled areas (Zhang et al. 1989, 82-3). At that point, the Central Office of the CYL had already been abolished and the CCP youth policy fell under the responsibility of the Central Youth Work Committee (Zhonggong zhongyang qingnian gongzuo weiyuanhui 中共中央青年工作委员会, also known as *zhongyang qingwei* 中央青委), which had been initially denominated Department for Youth (*Qingnian bu* 青年部) and headed by Feng Wenbin from 1936 until 1938 (Zhang 2003, 106).<sup>1</sup> Feng had distinguished himself in Communist youth work since the Jiangxi period and would later serve as the secretary of the NDYL from 1949 to 1952 (Klein, Clark 1971, 282-5).

Despite unsuccessful attempts at reviving the CYL carried out around 1940 especially by Li Chang, a young activist who had joined the CYL in the mid-1930s and had become a member of the *zhongyang qingwei* 中央青委 in May 1938 (Feng 2010, 26-9), it was only after World War II, when the national salvation organisations had exhausted their purpose and the CCP-GMD negotiations had failed, that the question of rethinking the youth strategy of the CCP arose.

From August-September 1946, the Central Secretariat of the CCP convened two meetings in Yan'an to discuss the question of re-establishing the CYL. Two meetings were held, one on 26 August and the other on 13 September, with the former seeing the participation of Zhu De, Ren Bishi, Kang Sheng and Hu Qiaomu, among the others. Greater participation seemed to have been guaranteed at the second meeting, which was also attended by Liu Dingyi, Chen Boda, Xi Zhongxun and Liu Ningyi (Zheng 1993, 130, 133; see also Li 2009, 183; He et al. 1987, 121, 145). Both meetings were chaired by Ren Bishi, who had played a leading role in the Communist youth movement since the second half of the 1920s and who in 1946 was a member of the CCP Central Secretariat in charge of youth affairs (together with Feng Wenbin).<sup>2</sup>

<sup>1</sup> The Department of Youth, set up in 1936, continued until 1938, when the Central Youth Work Committee was formally established by the CCP Central Committee to strengthen its guidance over youth work. Since 1938 (until 1941), the CCP Central Youth Work Committee included Chen Yun, Feng Wenbin, Li Chang, Hu Qiaomu, Song Yiping and Liu Guang, with Chen Yun as secretary and Feng Wenbin as vice-secretary. In September 1941, the CCP centre decided on the following composition: Kai Feng, Feng Wenbin, Song Yiping, Jiang Nanxiang and Gao Langshan (Zhang et al. 1989, 88; Feng 2010, 26).

<sup>2</sup> Trained in the Soviet Union, Ren Bishi had become one of the most important leaders of the Youth League in the second half of the 1920s (being its secretary from 1927

These two meetings were in fact preceded by a proposal submitted on 25 June by the Central Youth Work Committee to the CCP Secretariat on reviving the CYL. This document was the result of a discussion that had developed among the cadres involved in the regional youth work committees under the direction of Ren Bishi (Zheng 1993, 129; Guo 1992, 142). Entitled “Proposal Regarding the Establishment of the New Democratic Youth League (Draft)” (*Guanyu chengli xin minzhuzhuyi qingniantuan jianyi - cao'an* 关于成立新民主主义青年团建议 - 草案), it reported on the youth work situation in areas under Communist control and invited the leadership of the CCP to reflect on the reconstruction of the Youth League. In many of these areas, very few cadres were involved in youth work (none in some areas) and the national salvation associations, where still present (for instance, in the Shandong area), had exhausted their mission. The document reported on a situation of neglect and a lack of support and direction in youth work, which had spread since 1942. Even when praising the work of the youth salvation organisations in mobilising young people in areas such as Shandong, the document highlighted the fact that these organisations were not strong enough as they were too ‘ordinary’ (*yiban* 一般) and ‘broad’ (*guangfan* 广泛), emphasising the need to create an organised nucleus of ‘young activists’ (*qingnian jijifenzi* 青年积极分子) in line with the changing needs of the Party and historical conditions. Therefore, it called for the establishment of a youth organisation firmly under the leadership of the Party, one designed to train a “reserve force” for the Party, “assist” the Party and promote the youth ‘vanguard role’ (*xianfeng zuoyong* 先锋作用). It then criticised the incorrect standpoint of letting youth work being the responsibility of the Party, administrative structures or other mass organisations, as well as the past situation in which the CYL was in competition with the Party (*xianfeng zhuyi* 先锋主义, ‘vanguardism’; He et al. 1987, 104-18, in particular 114).

The document made clear that the re-established Youth League should be an organisation with a political and educational nature and broader membership requirements than the CCP and former CYL, but with ‘stricter’ (*yan jiezhi*) requirements than current ordinary mass organisations, advancing the idea that the membership should ideally consist of 25-30% of all young people and, in terms of social composition, have young workers and peasants as its core force.

When it came to the organisational structure, the document delineated the basic elements that would come to characterise the CYL after 1949: the principle of democratic centralism and an organisa-

---

to 1928). A member of the Central Committee of the CCP (1927) and of his Political Bureau (1931), from 1933 to 1938 he was one of the most important political leaders of the Red Army and in the 1940s worked closely with Mao Zedong (Klein, Clark 1971, 411-16).

tional structure composed of branches and committees at every administrative level, specifying that the organisation would provide leadership for youth and children work. Regarding CYL-CCP relations, the document stated that “both at the level of policy and tasks, it is under the leadership of the Party, but in daily work, it has its own independence, the Party should not intervene”. In addition, the document clarified that Youth League cadres would be appointed with the approval of the CCP from the central to the lower levels, and all league decisions were to be approved by the Party committee at the same level (He et al. 1987, 117-18). Therefore, this document provided the first organisational outline of the CYL structure, which envisaged a parallel hierarchy with the CYL dependent at all levels on the CCP.

The document formed a basis for further discussion of youth issues at the time. The two meetings convened by the Central Secretariat of the CCP between August and September of that year saw the cadres in charge of youth work in the various regions under Communist control report on the situation at the local level. The discussion focussed on the question of whether and how the CYL should be re-established, and touched upon leadership issues, the possible denomination, tasks and nature of the organisation (the minutes, albeit incomplete, are available in Gongqingtuan zhongyang qingyunshi gongzuo zhidao weiyuanhui et al. 2002, 564-88).

At both meetings Ren Bishi stressed that 400 young activists (*qingnian jiji fenzi* 青年积极分子) had emerged in the course of the struggle against Japan, representing 20% of the youth population in the “liberated areas” across the country, among whom a small number had joined the CCP (Gongqingtuan zhongyang qingyunshi gongzuo zhidao weiyuanhui et al. 2002, 576; He et al. 1987, 135, 146). They needed to be organised to play a role in guiding the broad masses of youth towards the tasks set by the Party. The ideological and political education of future generations was an issue that could not be ignored when considering a possible Communist takeover, and young people had specific interests, problems and characteristics that required a targeted organisational effort. According to Zhu De, the education and training of new generations had to be at the centre of the daily work of the reconstituted CYL; young people would receive an education in the “new democracy” through practice and concrete action, that is, by taking part in production work, agrarian reform, and support of the army (He et al. 1987, 124-6; Zheng 1993, 130).

The talk delivered by Ren Bishi on 26 August touched upon five main issues: leadership and work methods, tasks and denomination, nature of the proposed organisation, relations with other mass youth organisations and finally, organisation-building. Regarding the first point, he urged the cadres to beware of mistakes made in the past when performing youth work, explicitly referring to the tendency of the previous CYL to act as a second party (*di er dang xianxiang* 第二党现象).

These mistakes included not only the adoption of a style (vanguardism) borrowed from the Party – a tendency that in the period of the national revolution (up to 1927) was due to the fact that the Youth League had been created before the party and its building had preceded that of the CCP in places where the Party had not yet been built –, but also the tendency towards ‘youthism’ (*qingnianzhuyi* 青年主义) and ‘independence’ (*dulixing* 独立性) that occurred during the war of resistance against Japan. At that time, many youth organisations in Communist-held areas had developed into virtually autonomous groups. As Ren Bishi stated:

today the CCP leadership is stronger, it is not easy for the Youth League to make the mistake of adopting a second party style, but if we do not guard against it, discord with the Party may occur. (Ren 1987, 404)

As such, the CYL, if re-established, would need to pay attention to the characteristics of young people and their suitable working methods simply because young people were the target of the Youth League’s work. Therefore, education would represent a key concern in youth work as the educational training of new generation was considered extremely important. Ren Bishi finally referred to the experience of the Communist Party of the Soviet Union in leading the Komsomol as worth studying by Chinese cadres. Regarding the second issue pertaining to basic CYL tasks and denomination, he stated that “the basic tasks of the Party are the basic tasks of the Youth League”, and since at present this task is “struggling for the new democracy” (*wei xin minzhuyi er fendou* 为新民主主义而奋斗), a denomination such as the “New Democratic Youth League” or “Democratic Youth League” would be appropriate for providing a broader definition more open to different social groups and preventing the organisation from becoming too narrow. Moreover, he highlighted the political nature of the organisation and its role as an assistant to the CCP. If, on one hand, the new organisation needed to be much larger than the prior CYL, on the other it was necessary to create an advanced nucleus. Therefore, Ren Bishi affirmed that other mass youth organisations had to be developed, simultaneously with the revived Youth League being the pivot. Finally, he addressed the issue of how to proceed with organisation-building in areas under Communist control, stating that there was a need to start at a local level, with the local CCP branches having a leading role in setting up the corresponding Youth League branches (Ren 1987, 404-5).

The second meeting, held in September, came after Mao Zedong had approved the idea of reviving the youth organisation and was aimed at further soliciting opinions and addressing the last doubts that some cadres still had on the issue. Xu Teli, then member of the

CCP Central Committee and Vice-Director of the Propaganda Department, addressed the issue of the CCP and adult leadership and stated that adults should lead the youth since adults were able to address their specific requests, provide them an education and lead them into society and the CCP (He et al. 1987, 158). This raised the importance of providing new blood for the Party, but also conveyed the idea of the youth as junior and subject to CCP and adult authority, which was in line with a major shift in the conception of youth that had also emerged from Mao Zedong's 1939 talk "The Orientation of the Youth Movement", where he had praised the young people's vanguard role, while emphasizing the integration of students with the rural masses and the cultivation of the youth rather than their emancipation (Graziani 2019). During this second meeting, the question of youth work in areas still under GMD control was also raised, with Ren Bishi (Ren 1987, 406) stating that key importance was to be given to winning over the youth in competition with the Three People's Principles Youth Corps (*Sanminzhuyi Qingnian tuan* 三民主义青年团),<sup>3</sup> a youth organisation that the GMD had launched in 1938, amid the Sino-Japanese War, as an instrument to strengthen the Party while disciplining students and tackling their political activism (Huang 1993; Eastman 1984, 89-107). In general, in his talks during these central meetings, Ren Bishi emphasised the need to prevent the league from arguing for "independence" and ensured that its responsibilities were confined mainly to educating young people and organising them to participate in production and construction.

Following these meetings, the Central Youth Work Committee began building the organisation in Yan'an, where the first branches were created in factories, schools and the countryside. At the same time, on 5 November, the Central Committee of the CCP issued a proposal on building the Democratic Youth League (*Zhongyang guanyu jianli minzhu qingnian tuan de tiyi* 中央关于建立民主青年团的提议; Zheng 1993, 136-7), which read:

The Central Committee believes that today a new organisation of young activists should be built; this organisation should be larger [*qunzhonghua* 群众化] and more rejuvenated [*qingnianhua* 青年化] than the past Communist Youth League and should be under the leadership of the CCP. Its name will be the Democratic Youth League or the New Democratic Youth League.

---

**3** The issue of the competition with the GMD Youth Corps had been raised a few years before by Li Chang, when he proposed the re-establishment of the CYL considering the difficulties that broad and loose youth national salvation corps encountered in winning over youth. Later, during the Yan'an rectification campaign, he was criticised for adopting a "second party style" and for "vanguardism" in youth work (Feng 2010, 27-9).

The target of the revived organisation would be young people between the ages of 15 and 23, and the organisation would be based on the principle of democratic centralism and provide education on the thought of Mao Zedong, which had just been elevated to an official doctrine at the Seventh CCP National Congress. The document also made clear that while “the CCP and the government would not directly command the Youth League”, the league would “observe government decisions”, implement government directives and submit itself to the CCP leadership and never develop in opposition to the Party and government. Moreover, it stated that in ‘liberated’ areas it would be built by the youth federation cadres, while the question of whether it was needed in GMD-controlled areas was left open for further discussion (*Tuan zhongyang qingyunshi yanjiushi et al.* 1988, 633-5).

### **3 The Experimental Set Up of New Youth Organisations in Communist-Controlled Areas**

Based on these decisions, starting in the autumn of 1946, the regional offices of the CCP began the work of building the Democratic Youth League on an experimental basis. This process would continue up to September 1947, when the Youth League construction in Communist-controlled areas accelerated parallel to the development of the agrarian reform (Zheng 1993, 138-9; Li 2009, 197-200). In this regard, important meetings were held: a meeting on the land issue convened by the CCP Central Committee and a meeting on youth work in Communist-controlled areas convened by the Central Youth Work Committee, which discussed the question of Youth League-building and decided to expand and accelerate the process of setting up the league while carrying out the land reform. Liu Shaoqi gave instructions regarding the work of reviving the Youth League, underlining five key issues: 1) education and study as the most important tasks of the League; 2) the importance of ideological construction; 3) using caution when building the organisation by focussing on the quality of youth rather than the quantity; 4) adopting a correct work style, which meant having an honest, progressive and revolutionary style and serving the people and their interests; and 5) paying attention to the training of cadres (Zheng 2004, 131-2).

Local sections also arose in urban areas. Activities among young people became particularly important to the CCP in the struggle for the ‘liberation’ of cities. For example, in Beijing, where the urban proletariat was very limited, winning over students and intellectuals became an imperative for Chinese Communists (Yick 1995, 80-136). On the other hand, as it has been shown, the ultimate success of the CCP was due to both issues of strategy and the loss of consensus and credibility that the GMD was facing. Attempts to tame

and suppress the student protest movement that had arisen over the resumption of the civil war and foreign domination in China caused the GMD government to progressively alienate students and intellectuals (Pepper 1986).

In addition to the sections of the Democratic Youth League, other youth organisations also emerged in Communist-controlled cities, including the Youth Federation of Liberated Areas, the Chinese chapter of the Soviet-sponsored World Federation of Democratic Youth, that would be renamed the 'All-China Youth Federation' following a CCP politburo meeting at Xibaipo in September 1948, and turned into an umbrella organisation for all youth groups within which the Youth League would have a guiding role (Zheng 1993, 140-1). In Harbin, the Federation, established as early as August 1946, led 1400 students in land reform work in suburban areas between 1946 and 1948 and 5000 students in propaganda and service to soldiers (Pringsheim 1962, 86-8). By 1948, as the Youth League organisations were formally built in Harbin and other cities of the Northeast region, more than 80% of the Federation's members had become league members (Li 2009, 194, 198-9).

Further steps towards the revival of the CYL were taken on the eve of the Communist victory in the civil war, when the experimental process of building the league had already been extended to Communist-controlled areas in the regions of Dongbei, Xibei, Huabei and Huadong, despite being organisations with different names, such as the Mao Zedong Youth League, Democratic Youth League and New Democratic Youth League (Zheng 2004, 132). In September 1948, the newly founded Central School (*Zhongyang Tuanxiao* 中央团校) began its first term in Hebei (Pingshan County) as the main centre for the education and training of youth cadres, and in December the journal *Zhongguo qingnian* 中国青年 (Chinese Youth), originally founded in 1923 as an organ of the Socialist Youth League, resumed publication under the direction of the CCP's Central Youth Work Committee and featured an article by Zhu De entitled "The Present Tasks of Chinese Youth" (*Zhongguo qingnian dangqian de renwu* 中国青年当前的任务; Zheng 2004, 133; Li 2012, 188-9, 196-7; Townsend 1967, 15). Besides reproducing documents on the youth movement, presenting and commenting on "role models" and promoting discussion on certain centrally promoted policies, the journal had to present and explain the CCP line in such a way as to obtain the full support of young people. As such, this journal would soon become a key tool for the political socialisation of the youth in the PRC, becoming an official publication of the NDYL Central Committee along with the newspaper *Zhongguo qingnian bao* 中国青年报 (published since 1951; Townsend 1967, 24-6).

Following the experimental operation of the Democratic Youth League in Communist-held areas, on 10 October 1948 the CCP Cen-

tral Committee announced in a “Circular on the September (Politburo) Meeting” that the “New Democratic Youth League” would be launched in the first half of the following year (Saich 1996, 1322). As a result, on 1 January 1949, the Central Committee approved the “Resolution on the Establishment of the New Democratic Youth League”, summing up the historical experience of youth work and praising the work and positive contributions offered by the various local sections that had been experimentally established between 1946 and 1948 in enrolling young people in the army, guiding them in the development of production and enabling them to take part in agrarian reform and cultural activities. The resolution also formally established the nature and functions of the new organisation in view of the convening of the First National Congress:

The New Democratic Youth League is a mass organisation of advanced young people who are resolutely fighting for the new democracy under the political leadership of the CCP; it is the core through which the CCP unites and guides the vast masses of young people; it is the school through which the CCP educates young people in Marxism-Leninism. (Tuan zhongyang qingyunshi yanjiushi et al. 1988, 708)

The resolution defined the age limits for joining the organisation (15-25 years) and established that the league had the task of uniting and educating the masses of youth as well as organising them in the struggle for the liberation of China and for advancing the cause of the “new democracy”. Accordingly, it was stipulated that the organisation had to be broader than the past CYL so as to attract youth activists from all “democratic classes”. While expanding its mass base, it was nevertheless to remain an organisation of advanced activists, thus being different from ordinary youth groups: “Only by organising activists among Chinese youth, we can provide the vast masses of youth with a strong nucleus” (Tuan zhongyang qingyunshi yanjiushi et al. 1988, 708). It was further explained that membership in the league was to be voluntary and indications were also given on how to proceed with the organisational construction in cities, factories, the army, schools and elsewhere. After the resolution was approved, a committee headed by Ren Bishi was formed to perform the preparatory work for the convening of the National Congress that would formally inaugurate the new organisation a few months later (Li 2009, 200-2).



## 4 Conclusions

Since 1949, the league has played a crucial role in the political mobilisation and socialisation of young people, becoming a key group in the landscape of official PRC youth associations. Its functions, role and structure have very much resembled the Komsomol model, with the CCP maintaining a strong influence on youth policy decisions and cadre development. This essay has shown that, while CYL antecedents dated back to the early 1920s, it was only after the Sino-Japanese War, in the context of the CCP-GMD struggle for control of China, that the question of establishing the Youth League as a distinct but politically subordinated organisation arose, and the major features of its organisation and design emerged. Realising the importance of strengthening its leadership over youth work and disciplining young people, the CCP decided to experimentally set up new organisations in ways that would also limit the league's development and accumulation of power vis-à-vis the party. This process was started at a time when the national salvation youth organisations created in the mid and late 1930s had outlived their usefulness and was driven by an awareness that the progressive youth that had emerged in the course of fighting against Japan needed to be organised and disciplined in view of the Communist seizure of power. The idea of a highly hierarchical and centralised organisation subordinated to the CCP also grew out of discussions focussed on the need to prevent those erroneous tendencies that had in fact characterised the early organisational experience of the CYL.

## Bibliography

- Audin, J.; Doyon, J. (2019). "Intermediary Political Bodies of the Party-State: A Sociology of Mass and Grassroots Organizations in Contemporary China". *China Perspectives*, 2, 3-8.
- Barnett, D.A. (1951). "Mass Political Organizations in Communist China". *The Annals of the American Academy of Political and Social Science*, 227, 76-88.
- Doyon, J. (2023). *Rejuvenating Communism: Youth Organizations and Elite Renewal in Post-Mao China*. Ann Arbor: University of Michigan Press.
- Eastman, L. (1984). *Seeds of Destruction: Nationalist China in War and Revolution, 1937-1949*. Stanford: Stanford University Press, 89-107.
- Feng Lanrui 冯兰瑞 (2010). "Qingniantuan de jianli, gaizao yu chongjian" 青年团的建立, 改造与重建 (The Establishment, the Reform and the Rebuilding of the Youth League). *Yanhuang Chunqiu* 炎黄春秋, 10, 25-30.
- Gongqingtuan zhongyang qingyunshi gongzuo zhidao weiyuanhui 共青团中央青运史工作指导委员会 (CYL Central Guiding Committee on the history of the youth movement); Zhongguo qingshaonian yanjiu zhongxin 中国青少年研究中心 (China Youth and Children Research Center); Zhongyang dang'anguan liyong bu 中央档案馆利用部 (Central Archives Department) (eds) (1995). *Zhongguo qingnian yundong lishi ziliao* 中国青

- 年运动历史资料 (Historical Material on China's Youth Movement), vol. 13. Beijing: Zhongguo qingnian chubanshe.
- Gongqingtuan zhongyang qingyunshi gongzuo zhidao weiyuanhui; Zhongguo qingshaonian yanjiu zhongxin; Zhongyang dang'anguan liyong bu (eds) (2002). *Zhongguo qingnian yundong lishi ziliao* 中国青年运动历史资料 (Historical Material on China's Youth Movement), vol. 16. Beijing: Zhongguo qingnian chubanshe.
- Gongqingtuan zhongyang qingyunshi gongzuo zhidao weiyuanhui; Zhongguo qingshaonian yanjiu zhongxin (eds) (2003). *"Cikasha" liuxue suiyue. Sulian zhongyang tuanxiao zhongguoban xueyuan huiyilu* 茨卡莎留学岁月. 苏联中央团校中国班学员回忆录 (Recollections of Chinese students attending the Youth League Central School in the Soviet Union). Beijing: Zhongguo qingnian chubanshe.
- Graziani, S. (2013). *Il Partito e i giovani. Storia della Lega giovanile comunista in Cina*. Venezia: Cafoscarina.
- Graziani, S. (2014). "Youth and the Making of Modern China". *European Journal of East Asian Studies*, 13(1), 117-49.
- Graziani, S. (2019). "May Fourth Youth Day from Yan'an to the Early People's Republic: The Politics of Commemoration and the Discursive Construction of Youth", in Ya-pei Kuo (ed.), "A Century Later: New Readings of May Fourth", monogr. no., *Twentieth-Century China*, 44(2), 237-52.
- Guo Xiaoping 郭晓平 (1992). *Zhongguo gongqingtuan shi* 中国青年团史 (A History of the Chinese Communist Youth League). Wuhan: Huazhong shifan daxue chubanshe.
- He Qijun 何启君 et al. (1987). *Qingniantuan de chuian* 青年团的初建 (The Early Construction of the CYL). Beijing: Zhongguo qingnian chubanshe.
- Huang, J. (1993). "The Formation of the Guomindang Youth Corps: An Analysis of Its Original Objectives". *East Asian History*, 5, 133-48.
- Klein, D.W.; Clark, A.B. (1971). *Biographic Dictionary of Chinese Communism, 1921-1965*. Cambridge: Harvard University Press.
- Li Yuqi 李玉奇 (2009). *Zhongguo gongqingtuan shigao, 1922-2008* 中国青年团史稿 (A History of China's CYL, 1922-2008). Beijing: Zhongguo qingnian chubanshe.
- Li Yuqi 李玉奇 (2012). *Gongqingtuan lishi shang de 100 ge youlai* 共青团历史上的100个由来 (One Hundred Causes in the History of the CYL). Beijing: Zhongguo qingnian chubanshe.
- Mulready-Stone, K. (2015). *Mobilizing Shanghai Youth: CCP Internationalism, GMD Nationalism and Japanese Collaboration*. London: Routledge.
- Pepper, S. (1986). "The KMT-CCP Conflict 1945-1949". Fairbank, J.K.; Feuerwerker, A. (eds), *The Cambridge History of China*. Vol. 13(2), *Republican China: 1912-1949*. Cambridge: Cambridge University Press, 723-88.
- Pringsheim, K.H. (1962). "The Functions of the Chinese Communist Youth Leagues, 1920-1949". *The China Quarterly*, 12, 75-91.
- Ren Bishi 任弼时 (1987). *Ren Bishi xuanji* 任弼时选集 (Selected Works of Ren Bishi). Beijing: Renmin chubanshe.
- Saich, A. (ed.) (1996). *The Rise to Power of the Chinese Communist Party: Documents and Analysis*. Armonk: M.E. Sharpe.
- Samarani, G. (2003). "Figli della rivoluzione. I Giovani Pionieri nella Cina socialista (1949-1966)". *Annali Istituto Gramsci Emilia-Romagna*, 4-5, 333-46.
- Solieri, F. (2003). "Il Partito Comunista Cinese e i movimenti giovanili durante la guerra sino-giapponese: alcuni spunti di riflessione". *Annali Istituto Gramsci Emilia-Romagna*, 4-5, 347-61.

- Stranahan, P. (1998). *Underground: The Shanghai Communist Party and the Politics of Survival, 1927-1937*. Lanham: Rowman & Littlefield.
- Townsend, J.R. (1967). *Revolutionization of Chinese Youth: A Study of Chung-kuo Ch'ing-nien*. Berkeley: University of California Press.
- Townsend, J.R. (1969). *Political Participation in Communist China*. 3rd ed. Berkeley: University of California Press.
- Tsai, W.; Liao, X. (2021). "Institutional Changes, Influences and Historical Junctures in the Communist Youth League of China". *The China Quarterly*, 248(S1), 161-80.
- Tsimonis, K. (2021). *The Chinese Communist Youth League: Juniority and Responsiveness in a Party Youth Organization*. Amsterdam: Amsterdam University Press.
- Tuan zhongyang qingyunshi yanjiushi 团中央青运史研究室 (League Central Research Office on the History of the Youth Movement); Zhongyang dang'an-guan 中央档案馆 (Central Archives) (eds) (1988). *Zhonggong zhongyang qingnian yundong wenjian xuanbian 中共中央青年运动文件选编* (Collection of Documents of the CCP Central Committee on the Youth Movement). Beijing: Zhongguo qingnian chubanshe.
- Yi, S. (2022). "Brothers, Comrades or Competitors? The Communist Party and Youth League in Shanghai, 1925-1927". *History*, 107(374), 121-42.
- Yick, J.K.S. (1995). *The Making of Urban Revolution in China: The CCP-GMD Struggle for Beijing-Tianjin 1945-1949*. Armonk: M.E. Sharpe.
- Yin Hongbiao 印红标 (1992). "Qingnian gongchanguoji he Zhonggong gongqingtuan de gaizao" 青年共产国际和中国共青团的改造 (The Communist Youth International and the Reform of China's Communist Youth League). *Zhongguo qingnian yanjiu 中国青年研究*, 3, 8-11.
- Zhang Heng 张恒 (ed.) (2003). *Zhonggong zhongyang zuzhi renshi jianming tu-pu 中共中央组织人事简明图谱* (Concise Atlas of Personnel and Organisation of the Central Committee of the Chinese Communist Party). Beijing: Zhongguo guangbo dianshi chubanshe.
- Zhang Jingru 张静如; Wang Jingsheng 王京生; Hao Ruiting 郝瑞庭; Wang Binglin 王炳林 (eds) (1989). *Zhongguo qingnian yundong cidian 中国青年运动词典* (Dictionary of China's Youth Movement). Shijiazhuang: Hebei renmin chubanshe.
- Zheng Guang 郑洪 (ed.) (1993). *Mao Zedong ji qi zhanyou yu Yan'an shiqi qingnian yundong 毛泽东及其战友与延安时期青年运动* (Mao Zedong and His Comrade-In-Arms and the Youth Movement in the Yan'an Era). Xi'an: Shanxi renmin jiaoyu chubanshe.
- Zheng Guang 郑洪 (2004). *Gongqingtuan lishi shang de ren he shi 共青团历史上的人和事* (Personalities and Events in the CYL History). Beijing: Zhongguo qingshaonian yanjiu zhongxin.
- Zhongyang tuanxiao qingniantuan gongzuo jiaoyanshi 中央团校青年团工作教研室 (Central League School's Teaching and Research Office on the CYL Work) (ed.) (1979). *Zhongguo qingnian yundong lishi wenjian xuanbian 中国青年运动历史文件选编* (Selected Documents on the History of China's Youth Movement). Beijing: neibu jiaocai 内部教材.



**The Historian's Gaze**

Essays on Modern and Contemporary China  
in Honour of Guido Samarani

edited by Laura De Giorgi and Sofia Graziani

# The Two World Wars and China's Changing International Status

Hongmin Chen

Zhejiang University, China

**Abstract** In the genesis of China as a modern nation-state, the relationship with the outside world played a fundamental role. The goal of this essay is to outline the fundamental factors that shaped the relationship between China and the League of Nations and between China and the Organization of the United Nations during and following the two world wars, offering an interpretative reading from the perspective of China's transformation into a modern nation-state. The choice to focus on these two international organisations is due to the fact that China's bilateral relations with each specific country were very different, making generalisations quite difficult. Conversely, both the League and the United Nations can be considered as representing the world as a whole. As the two world wars were the most important international events in the first half of the twentieth century and prompted the establishment of the two most important, largest and most influential international organisations, China's relations with the League of Nations and later with the United Nations during those periods represent an important case study for understanding the transformation of China's international status and the world's acceptance and recognition of China.

**Keywords** World War I. World War II. China's international status. League of Nations. United Nations.

**Summary** 1 China and the League of Nations (World War I). – 2 China and the United Nations (World War II). – 3 Conclusions.

The relation between Chinese history and the two world wars is a quite complicated and multi-faceted historical subject. To focus on one specific aspect, this essay outlines the most basic aspect of China's relations with the League of Nations and the United Nations during and following the two wars, offering some interpretations.



Edizioni  
Ca' Foscari

**Sinica venetiana 10**

e-ISSN 2610-9042 | ISSN 2610-9654

ISBN [ebook] 978-88-6969-723-4 | ISBN [print] 978-88-6969-724-1

**Peer review | Open access**

Submitted 2022-07-26 | Accepted 2022-09-17 | Published 2023-10-11

© 2023 Chen | © 4.0

DOI 10.30687/978-88-6969-723-4/009

The choice to focus on relations with international organisations is due to the fact that the bilateral relations between China and each individual country were extremely diverse, which makes generalisations difficult. Conversely, as international organisations gather many countries, they can best be seen as representing Chinese relations with the outside world.<sup>1</sup>

The construction of a modern nation-state owes much to the efforts of all internal forces to build a modern country as well as to the country's relationship with the world and its recognition by other countries. Consequently, China's changing international status should also be measured against this standard.

The two world wars were the most important international events in the first half of the twentieth century, shaping global history. After World War I and World War II, the two largest, most important and most influential international organisations in modern times were established, respectively the League of Nations and the United Nations. The relations of China with these new organisations, as well as its role within them, are emblematic of the transformation of China's international status and the degree to which China is accepted and recognised by the outside world.

## 1 China and the League of Nations (World War I)

In 1912, the Republic of China was established, and through its new face as Asia's first democratic republic, China's international status had slightly improved, although it basically remained the 'banquet' of a club of international powers. In 1915, Japan forced Yuan Shikai 袁世凯 to sign the Twenty-One Demands. This humiliating treaty, signed without being the consequence of an actual military conflict and defeat, was quite unusual in modern China, and aroused a widespread popular anger. The day the Twenty-One Demands were signed, 9 May, was subsequently considered as the 'day of national humiliation'.

On 28 July 1914, Austria-Hungary declared war on Serbia, and World War I broke out. Because the war took place in distant Europe (China initially called it the 'European War'), it had little direct relationship with China. After the war broke out, on 6 August 1914, the Chinese government claimed its neutrality in the European conflict.

---

The contribution was translated from Chinese by Laura De Giorgi.

<sup>1</sup> A preliminary version of this essay was presented as a keynote speech entitled "Approaching to the Center: China's Steps to the International Stage" at the international conference *1919-1949: The Birth of Modern China*, jointly organised in Venice in December 2019 by the Department of Asian and North African Studies of Università Ca' Foscari and by the Research Center for Chiang Kai-shek and Modern China of Zhejiang University. The original draft has been substantially revised by the Author.

In those years, China was going through the era of Yuan Shikai and, after his death, the warlord period. Both warring parties in the European conflict wanted to win over China. Intense political debates took place in China over whether to participate in the war. In the end, China declared war on Germany and Austria-Hungary on 14 August 1917, and sided with the Triple Entente. The United Kingdom, the United States, Japan, Italy and other countries of the Allied Powers expressed their welcome and declared that they would do their best to help China enjoy “the proper status and preferential treatment of a major country” in the world (Shi 1994, 130). Although China did not send soldiers to fight in Europe, it provided a large amount of food to the Allied Powers and sent 140,000 Chinese workers to France and other places to serve on the front lines. About 20,000 Chinese nationals died in foreign countries. Fortunately, the Allies won the war.

According to Xu Guoqi, China's participation in World War I was of great significance, “marking the beginning of the Chinese people's real search for internationalisation and a new national identity” (2005, transl. by Ma 2019, 1).

As a victorious country, China participated in the Paris Peace Conference: “For the first time China put forward its appeal for equality to the world, expressing its desire to join the international community as an equal member” (Xu 2005, transl. by Ma 2019, 1).

In January 1919, the peace conference took place in Paris, and representatives from 27 countries, including China, attended it. Before the meeting, US President Thomas Woodrow Wilson put forward the Fourteen Principles as a *programme for establishing world peace*. The Chinese had great expectations of the Paris Peace Conference, believing that victory in World War I had been the victory of justice over arrogance, that the peace conference would uphold justice, and that China would regain all the rights it had lost. A Chinese translation of President Wilson's wartime speeches became very popular. Intellectual circles were optimistic about the future. The President of Beijing University, Cai Yuanpei 蔡元培, delivered a speech in Tiananmen Square, claiming that from then on, “the obscurantism of inequality at all international levels will be eliminated and substituted by enlightenment” (Shi 1994, 151).

At the Paris Peace Conference, the Chinese delegation submitted several *memoranda* on the Shandong question and on its wishes, requesting the abolition of the privileges of foreign powers in China and the recovery of its rights and interests in Shandong. But at the conference, the great powers not only rejected China's legitimate requests but also transferred the pre-war German privileges in Shandong to Japan. When the news of China's ‘diplomatic failure’ at the Paris Peace Conference reached the country, Chinese intellectuals were greatly disappointed, and the well-known May Fourth Movement took place. The Chinese representatives even refused to sign the Treaty of Versailles.

However, if we look at the historical significance of the event, China's participation in the Paris Peace Conference represented a huge progress. First, it was the first time that China participated in a large-scale multilateral international conference, attending it as a victorious country. Moreover, regarding the Paris Peace Conference itself, China was partially successful in presenting a new national image to the world, and it also participated in the process of creating a new world order. Secondly, whereas in most bilateral or multilateral international negotiations in which it had previously participated, China had been forced to concede land for compensation and its sovereignty had been damaged, at the Paris Peace Conference, China made it clear to the whole world for the first time that it wanted to amend unequal treaties and to strive for equal international status. Although the goal was not achieved, the most important first step was taken.

World War I brought opportunities for the rapid development of China's industry and commerce. During the conflict, due to disputes between the great powers, their attention to investments in the East diminished. Conversely, especially in sectors such as grain processing and textiles, China's light industry developed rapidly and the number of enterprises increased. This was the 'golden age' of China's national capitalist development. As a victorious country, China stopped paying the high indemnities for the Boxer Protocol. This protocol, signed in 1901, stipulated that China had to pay foreign powers a total of 450 million silver *taels* (including interest of about 980 million *taels*). Following its participation in World War I, China suspended the payment of indemnity to some allies; by declaring war on Germany and Austria, it terminated the payment of indemnities to these enemy countries; and with the Russian Revolution in 1917 and the fall of Tsarist power, the newly established Soviet Union and China agreed that the latter would no longer have to pay compensation. Overall, this was a considerable result, permitting China's exhausted finances to take a breath.

On 10 January 1920, the day the Treaty of Versailles came into effect, the League of Nations was established. All countries that had declared war on the German and Austrian coalition during the Great War and several newly established countries were its founding members. The League of Nations was the first universal international organisation in human history with the purpose of maintaining world peace and security. It was also the largest international organisation after World War I, with more than fifty member states at its largest and with headquarters situated in Geneva. Due to China's refusal to sign the Treaty of Versailles, it failed to join the League of Nations at the beginning, but it became a member on 29 June 1920, after signing the Treaty of Saint-Germain against the former Austro-Hungarian Empire.

By adhering to the League of Nations, China had become a member of an international organisation for the first time. At that time, however, civil wars were still frequent and the North and South were



divided. For these reasons, the Republic of China was incapable of playing its proper role in the League of Nations and often even delayed the payment of its membership dues. The Western powers that dominated the League of Nations did not care much about Far East affairs. F.P. Walters, who was the Deputy Secretary-General of the League, recalled that Western countries were “unwilling to listen” to the speeches of the Chinese representatives at the conference (1952, transl. by Han Ao, *Nin Jing* 1964, 370).

In 1928, after the Nationalist government completed China's national unification, it began to establish a closer relationship with the League of Nations. The League established a technical cooperation committee with China and sent Ludwik W. Rajchman, Director of the Health Organization, to China as a technical cooperation representative. Rajchman inspected the science, health and agriculture sectors in China and submitted a report to the League Council. Subsequently, the League sent several experts in healthcare and agricultural technology to China. Chiang Kai-shek 蒋介石 was not fully satisfied with this outcome, as he had hoped that the League would play a role in helping China abolish the unequal treaties. As he told the League of Nations representative,

China is subjected to unequal treaties, and it is the League of Nations's responsibility if it still permits that one of its members endures these unequal conditions; this is a shame for the League. The association's prestige and capacity depend on whether it can help China to cancel these treaties.<sup>2</sup>

On 18 September 1931, Japan invaded Manchuria. Chiang Kai-shek refused to negotiate directly with Japan, accepted Rajchman's suggestions and instructed Shi Zhaoji 施肇基, the Chinese representative to the League of Nations, to file a complaint with the Council, requesting that the League send an investigation team. Chiang nourished great hopes in the League of Nations, and he concluded that it would support China: “This time the League of Nations came out and intervened. If our country is able to be united in its relations with the outside world, China will have no personality, and the shame will not end”.<sup>3</sup> The League of Nations accepted China's appeal and sent an investigation team to Manchuria, headed by Victor Bulwer-Lytton, to understand the actual situation of Japan's invasion of China.

---

<sup>2</sup> Chiang Kai-shek 蒋介石 (1931). *Chiang Kai-shek Riji* 蒋介石日记 (Chiang Kai-shek's Diary), 3 April [handwritten]. The original is preserved in the Hoover Institution Library & Archives, Stanford University.

<sup>3</sup> Chiang Kai-shek 蒋介石 (1931). *Chiang Kai-shek Riji* 蒋介石日记 (Chiang Kai-shek's Diary), 23 September [handwritten].

In October 1932, the Report of the Lytton Commission of Inquiry was published simultaneously in Tokyo, Nanjing and Geneva. The report affirmed that Manchuria was a part of China's territory. It also offered a more objective account of the 18 September Incident and the Manchukuo puppet state, stating that China had been invaded. With forty votes in favour and only Japan voting against, the League of Nations' General Assembly issued a statement based on Lytton's report, denying the legal status of Manchukuo and demanding that Japan return Manchuria to China. When the report of the League of Nations was approved, Chiang commented: "Yesterday, the League of Nations proposed to recognise the Chinese sovereignty on Manchuria and not recognised Manchukuo's puppet state. Its attitude is quite good".<sup>4</sup> Of course, many Chinese were not satisfied with the report of the League of Nations and believed that Japan should be strongly condemned. Japan was greatly dissatisfied with the League of Nations' report and announced its withdrawal from the League on 27 March 1933. This is evidence that the League of Nations report was favourable to China.

The attitude of the League of Nations towards the Sino-Japanese dispute reflected how difficult the choice between China and Japan was for Western powers at that time. That is to say, it was impossible to have both. Should they choose the relatively mature Japanese market or the immature Chinese one that had, however, already shown unlimited potential? Western countries were not yet willing to lose the Japanese market, nor did they want to offend Japan, but they had begun to put China and Japan on both sides of the scales and weigh them. This was unthinkable in the past, even at the Paris Peace Conference just twelve years earlier.

## 2 China and the United Nations (World War II)

In July 1937, the Japanese war of aggression against China broke out. While resisting alone with its own forces, China sought for international assistance. On 12 September, Gu Weijun 顾维钧 (also known as Wellington Koo), the chief representative of the Republic of China to the League of Nations, formally filed a complaint, requesting that the League of Nations take appropriate and necessary methods and actions in accordance with the relevant provisions of the association in order to stop Japan's war of aggression against China. Later, denouncing the large-scale bombing atrocities committed by the Japanese invaders, the Chinese representative proposed that the

---

<sup>4</sup> Chiang Kai-shek 蒋介石 (1932). *Chiang Kai-shek Riji* 蒋介石日记 (Chiang Kai-shek's Diary), 14 February [handwritten].

League of Nations declare Japan an 'aggressive country' in accordance with the covenant and that member states take specific measures to sanction Japan.

The League of Nations' Far Eastern Advisory Committee passed a resolution condemning the atrocities of Japanese planes shelling China's undefended cities and killing civilians. On 6 October 1937, the General Assembly of the League of Nations officially approved a resolution declaring that Japan's military actions against China violated the obligations of the Nine-Power Treaty and the Kellogg-Briand Pact; it suggested that a summit of the countries in the Nine-Power Treaty should take place as early as possible as a way to seek an agreement and to end the conflict; it recommended that member states express moral assistance to China and refrain from taking any actions that might damage China's resistance and increase China's difficulties in this conflict; it also requested that member states attempt to assist China individually (Hong 2009).

In comparison with the Report of the Lytton Commission of Inquiry in 1932, this time the League of Nations showed a clearer attitude towards Japan's invasion of China, as it publicly condemned it and encouraged member states to aid China. However, the League of Nations knew that its binding force was very weak, so it proposed to convene a summit of the Nine-Power Treaty's countries to solve the problem.

As China was also assisting in the decline of the League of Nations, the focal point in winning international support consequently shifted to another multilateral international organisation: the Nine-Power Treaty. The Nine-Power Treaty is the shortened name of the Nine-Nation Treaty on Principles and Policies Applicable to China's Events, adopted at an international conference held in Washington in 1922. It had the nature of an international agreement. The core principle of the Nine-Power Treaty was the 'open door and equal opportunities' policy for all countries in China. It emphasised that China should be open to all countries, but it also had a certain binding effect on countries (especially Japan) that dreamed of monopolising China. In the following years, several countries joined the pact, and by 1937, there were 19 signatories to the Nine-Power Treaty.

When the news of the upcoming meeting of the Nine-Power Treaty's members was published, the Battle of Shanghai was taking place fiercely. To gain the support of the countries within the Nine-Power Treaty, Chiang Kai-shek even ordered a gradual loss of initiative on the battlefield, but the Chinese troops that were supposed to withdraw from Shanghai continued to fight to the death. China did not have extravagant expectations that a resolution of the Nine-Nation Treaty would sanction Japanese aggression, but it hoped that this would make a resolution of the League of Nations condemning Japan a reality. More concretely, it hoped that the governments and societies of the participating countries would step up their unanimous

economic sanctions against Japan (actively boycotting Japanese products) and that they would not passively help Japan with their financial and material resources. Moreover, China asked the major powers for loans for war expenses and armaments to help China.

In November 1937, a meeting of the Nine-Power Treaty's members was held in Brussels. In discussing the Sino-Japanese War, the meeting did not consider the adoption of several suggestions put forward by the Chinese delegation, especially the four suggestions on economic sanctions against Japan. The final declaration adopted at the meeting merely reiterated the principles of the Nine-Power Treaty and the importance of peace, inviting China and Japan to stop the war and adopt a peaceful procedure. Between China and Japan, the Nine-Power Treaty organisation faced the same difficult choice as the League of Nations, and did not issue the resolution that China expected.

Even after the outbreak of the war in Europe in September 1939, it was still difficult for the United Kingdom, the United States and other countries to make a clear choice between China and Japan. They did not dare to offend Japan and openly support China, and they sometimes even tried to appease Japan at the expense of China's interests.

On 7 December 1941, more than four years after China had fought alone against Japan, Japan attacked Pearl Harbor, and the Pacific War broke out. At this time, the strategic value of China's battlefield against Japan was highlighted, and the United States, the United Kingdom and other countries quickly became allies of China. On 31 December 1941, US President Franklin D. Roosevelt sent a telegram to Chiang Kai-shek, proposing that Chiang become the Supreme Commander of the Allied Forces in the China Theatre, commanding the Allies at that moment or in future operations in China, Vietnam and Thailand. This was the first time that a Chinese leader had been given command by an international military alliance. Subsequently, the Chinese army entered Burma to cooperate with the British army in fighting the Japanese.

On New Year's Day 1942, Hu Shi 胡适, the Chinese ambassador to the United States, signed the joint declaration of the United States, the United Kingdom, the Soviet Union and China against the Axis Powers. This was the sign of China's entry into the ranks of the 'world's top four'. Subsequently, in the United States, the White House announced the Joint Declaration of the United Nations signed by the United States, the United Kingdom, the Soviet Union, China and 22 other anti-Axis countries. The governments of the signatory countries pledged to use all their military and economic resources in the fight against fascist countries and to cooperate closely in the war, never concluding an armistice or peace with the enemy on their own. President Roosevelt proposed to list the United States, China, the United Kingdom and the Soviet Union ahead of the other 22 countries. For the first time, China nominally achieved the status

of a great power equal to that of the United States, the Soviet Union and the United Kingdom (Sherwood 1948 transl. by She 1980, 19).

In the autumn of 1942, China signed new separate treaties with the United Kingdom and the United States, which announced the abolition of colonial privileges, such as extraterritorial rights in China. In addition, China declared war on Japan and Germany, and the bilateral unequal treaties imposed on China by the great powers basically lost their effectiveness.

On 30 October 1943, at the meeting of the foreign ministers in Moscow, the United States, the United Kingdom and the Soviet Union signed the Declaration of the Four Powers on Universal Security, which clearly stated that they would jointly establish a new international organisation as soon as possible and established the idea that the four major powers would be the centre of gravity of this international organisation. For China, this further confirmed its status as a great power following the Declaration of the United Nations. In his congratulatory message to the leaders of the three major powers, Chiang Kai-shek said the following:

To hear the news of the signing of the joint declaration of the four countries, made me and the whole country and army happy. This historically important document shows the righteousness of fighting aggression to the whole world. It not only strengthens the cooperation between our four countries to achieve common beliefs, but also guarantees the establishment of international peace and universal security for peace-loving nations all over the world. This is a great contribution to the future of the world. (Qin 1981, 815)

In November 1943, Chiang Kai-shek, China's wartime leader, attended the Cairo Conference and discussed important issues such as the war against Japan and post-war arrangements with US President Roosevelt and British Prime Minister Winston Churchill. It was the first time in history that a Chinese leader sat on an equal footing with the leaders of world powers to discuss international plans.

At the Dumbarton Oaks Conference from late September to early October 1944, the United States, the United Kingdom, the Soviet Union and China reached an agreement on the goals and structure for the establishment of a world organisation, and the United Nations blueprint was drawn. On 13 February 1945, Chiang Kai-shek was very happy to learn through a call from the Ministry of Foreign Affairs that the United States, the United Kingdom and the Soviet Union would establish the United Nations to maintain world peace and security. He considered this "the first note of victory for the New Year" and thanked God.

On 25 April 1945, the representatives of fifty countries gathered in San Francisco to discuss the drafting of the Charter of the United Nations, and the Chinese delegation was among them. On 25 June,

the General Assembly adopted the United Nations Charter, which was the legal basis for the establishment of the United Nations. The Charter stipulates that the United States, the United Kingdom, the Soviet Union, China, and France are permanent members of the United Nations Security Council. The Chinese delegation, listed first alphabetically among the four sponsoring countries, was the first to sign the Charter. When Chiang Kai-shek heard the news, he was very happy and wrote that the “ratification of the UN Charter is a major event in the world”.<sup>5</sup>

In fact, in the process of participating in the preparation of the United Nations, China had quite a sober and prudent understanding of its ‘status as a great power’. When Chiang Kai-shek was invited to participate in the Dumbarton Oaks Conference, he told President Roosevelt that if there were no representatives of the Eastern peoples, “this conference would lose its meaning to half of the world’s human beings” (Qin 1981, 828). This meant that China positioned itself in the meeting as a ‘representative of the Eastern peoples’. During the preparation process for the United Nations, Chinese representatives often spoke from the standpoint of a small and weak country. Sun Fo 孙科 told the media that the Chinese people should regard obtaining the status of a great power as a “duty rather than a right” and that, being a duty rather than a right, China wanted to catch up with advanced countries, keep pace with world powers such as the United Kingdom and the United States, the Soviet Union and the future France, and jointly assume responsibility for maintaining world peace (*Zhongyang ribao* 1945).

It has been said that China’s victory in the War of Resistance against Japanese Aggression was a ‘tragic victory’. In fact, China did not yet have the strength to become a world power. It became one of the four powers as the result of President Roosevelt’s promotion of the US strategy, but China was a great power only illusorily. However, if we consider the historical process described above, China began by fighting Japan alone, then formed a military alliance with the anti-fascist countries, then its leader participated in international negotiations, and finally became the founding country of an international organisation. Measured by these events, China’s status as an important member of the international community after World War II is unquestionable.

---

<sup>5</sup> Chiang Kai-shek 蒋介石 (1945). *Chiang Kai-shek Riji* 蒋介石日记 (Chiang Kai-shek’s Diary), 25 August [handwritten].

### 3 Conclusions

If we look at modern China's efforts and its struggle for equal status in the international community as a curve, the period from 1840 to 1911 represents the first stage, in which China essentially sank and hovered at the bottom. The 1911 Revolution and the founding of the Republic of China forms the second stage of the curve, which China began to climb with difficulty, accelerating after 1919 and then reaching the peak in 1945.

The two world wars led to great changes in the world order. The United States was the greatest beneficiary. They successfully replaced the United Kingdom as the new world hegemonic power. China played a certain role in the two world wars (particularly by becoming an important ally in World War II). It sided with the victorious countries and reaped many benefits. The two world wars allowed China's international status to achieve a qualitative leap: from being an outsider to modern international organisations, it joined these international organisations and then became a founder, a permanent member of the Security Council and one of the 'big four'. From being insulted and bullied to being respected and becoming an equal member of the international community, China's efforts to step onto the international stage have achieved remarkable results.

In search of the reasons for this 'successful' path, we can identify the following domestic and international aspects. At the domestic level, after the founding of the Republic, China gradually changed its traditional worldview of seeing itself as the 'centre of the world' and embarked on the path of building a unified and independent modern country, striving to integrate with the world. By working hard, China made the world realise that it possessed the basic qualities of a modern country and had bright market prospects. In vol. 13 of *The Cambridge History of China, Republican China: 1912-1949*, J.K. Fairbank writes about China's new attitude: "From the autumn of 1936, a new sense of optimism and national unity permeated the whole country" (Fairbank, Feuerwerker 1986, transl. by Yang Pinquan 1993, 181). If we compare the psychological attitude of the Chinese in the 1900s and the 1930s, the latter is obviously more optimistic than the former.

At the international level, faced with the rare opportunities offered by the two world wars, China made the right choice in the contest between two groups of world powers in an era of great transformation, siding with the major countries that represented progress and thus sharing the fruits of victory. Of course, after joining the Allies, China also contributed to the alliance, particularly with its sacrifices and hardships in the War of Resistance against Japanese Aggression, which were widely praised by the Allies.

## Bibliography

- Chiang Kai-shek 蒋介石 (1931). *Chiang Kai-shek Riji* 蒋介石日记 (Chiang Kai-shek's Diary). Stanford: Hoover Institution Library & Archives, Stanford University.
- Chiang Kai-shek (1932). *Chiang Kai-shek Riji* 蒋介石日记 (Chiang Kai-shek's Diary). Stanford: Hoover Institution Library & Archives, Stanford University.
- Chiang Kai-shek (1945). *Chiang Kai-shek Riji* 蒋介石日记 (Chiang Kai-shek's Diary). Stanford: Hoover Institution Library & Archives, Stanford University.
- Fairbank, J.K.; Feuerwerker, A. (eds) (1986). *The Cambridge History of China*. Vol. 13(2), *Republican China: 1912-1949*. Cambridge: Cambridge University Press. Chinese transl.: Yang Pinquan 杨品泉 (transl.) (1993). *Qianqiao Zhonghua minguo shi* 剑桥中华民国史. Beijing: China Social Sciences Press.
- Hong Lan 洪岚 (2009). "Nanjing Guomin zhengfu de Guolian waijiao 1937-1941" 南京国民政府的国联外交 1937-1941 (The Nanjing Nationalist Government's Diplomacy at the League of Nations 1937-1941). *Huanan shifan daxue xuebao* 华南师范大学学报 (*Journal of South China Normal University*) – *Social Sciences Edition*, 4, 81-6.
- Qin Xiaoyi 秦孝仪 (ed.) (1981). *Zhonghua minguo zhongyao shiliao chubian – Dui Rikang zhan shiqi* 中华民国重要史料初编 – 对日抗战时期 (Preliminary Compilation of Important Historical Materials of the Republic of China – During the War of Resistance Against Japan). Vol. 3, *Zhan shi wai jiao* (Wartime Diplomacy). Taipei: Central Cultural Relics Service.
- Sherwood, R. (1948). *Roosevelt and Hopkins: An Intimate History*. New York: Harper & Brothers. Chinese transl.: She, W. 舍伍德 (transl.) (1980). *Luosifu yu Huopujisi – Dier da zhan shiqi baigong shilu* 罗斯福与霍普金斯 – 二次大战时期白宫实录 (Roosevelt and Hopkins – Records of the White House During the Second World War). Beijing: Commercial Press.
- Shi Yuanhua 石源华 (1994). *Zhonghua Minguo waijiao shi* 中华民国外交史 (A Diplomatic History of the Republic of China). Shanghai: Shanghai Renmin Chubanshe.
- Walters, F.P. (1952). *A History of the League of Nations*. New York: Oxford University Press. Chinese transl.: Han Ao 罕敖; Nin Jing 宁京 (transl.) (1964). *Guoji lianmeng shi* 国际联盟史. Beijing: Commercial Press.
- Xu, G. (2005). *China and The Great War: China's Pursuit of a New National Identity and Internationalization*. Cambridge: Cambridge University Press. Chinese transl.: Ma Jianbiao 马建标 (transl.) (2019). *Zhongguo yu da zhan: xun qiu xin de guo jia ren tong yu guo ji hua* 中国与大战: 寻求新的国家认同与国际化 (China and the World Wars: Sought a New National Identity and Internationalization). Chengdu: Sichuan Renmin Chubanshe.
- Zhongyang ribao* (1945). 对国际和平机构建议案孙科王宠惠发表观感 (Sun Fo and Wang Chonhui talk about the suggestion on the institution of international peace). *Zhongyang ribao* 中央日报 (Central Daily News), 12 October. Chongqing Edition.



**The Historian's Gaze**

Essays on Modern and Contemporary China  
in Honour of Guido Samarani

edited by Laura De Giorgi and Sofia Graziani

# A 'Multi-Voice' Choir. Making Foreign Policy in Post-Maoist China

Barbara Onnis

Università degli Studi di Cagliari, Italia

**Abstract** As a result of the People's Republic of China's increasing interdependence with the global arena and developing foreign policy interests, the Chinese foreign policy-making process has witnessed the emergence of a growing number of actors who wish to 'have a say' and attempt to influence the top leadership's decisions. In this process, while the Chinese Communist Party, and in particular its highest body (the Politburo Standing Committee), has retained ultimate decision-making power, the Ministry of Foreign Affairs has confirmed its 'secondary role' as merely one actor 'among the others,' and not necessarily the most important one.

**Keywords** Post-Maoist China. Chinese Foreign Policy. Foreign Policy Decision-Making. Traditional actors. Non-Traditional actors. Ministry of Foreign Affairs.

**Summary** 1 Introduction. – 2 The Emergence of New Players in the Foreign Policy Decision-Making Process. – 3 The Marginalisation of the Ministry of Foreign Affairs. – 4 Conclusions.

## 1 Introduction

As China rises as a world superpower and wants to have a greater say on international issues, whether on security, climate, or global governance, it becomes crucial to try to understand its foreign policy decision-making process, and above all the actors involved in the process. For many years after the People's Republic of China (PRC) was founded, the way this process functioned remained almost unintelligible, and most scholars and analysts "had to piece together snippets of information to identify the actors and institutions in China's foreign policy apparatus" (Zhao 2020, 85).



**Sinica venetiana 10**

e-ISSN 2610-9042 | ISSN 2610-9654

ISBN [ebook] 978-88-6969-723-4 | ISBN [print] 978-88-6969-724-1

**Peer review | Open access**

Submitted 2022-07-26 | Accepted 2022-12-07 | Published 2023-10-11

© 2023 Onnis | © 4.0

DOI 10.30687/978-88-6969-723-4/010

The initiation of the 'Reform and Opening-up policies' (*Gaige Kaifang Zhengce* 改革开放政策) in the late 1970s represented a turning point for contemporary China. The country opened up to the world through a process of growing international involvement, and scholars were given new opportunities to study China's foreign policy decision-making process. While a lack of transparency and high level of secretiveness remained huge barriers, scholars have been able to collect more information, both directly from Chinese publications and from insiders in the Chinese system (mainly retired Chinese diplomats), and put together an increasingly accurate (or at least less confused) picture of the Chinese foreign policy-makers and their interactions with bureaucratic institutions. From Doak Barnett's studies of China's foreign policy institutions (1985) to the studies of the country's foreign policy process by Lu Ning (1997) and those on the effects of various factors on its external behaviour from different perspectives (Lampton 2001; Hao, Su 2005; Rozman 2012; Zhang 2016) and the challenges of Chinese foreign policy decision-making (Yun 2013), to the most recent studies by Zhu Zhiqun (2020), David Shambaugh (2020), Shaun Breslin (2021), and Peter Martin (2021), research on Chinese foreign policy decision-making has proliferated. These studies have made a major contribution towards advancing academic understanding of Chinese foreign policy decision-making mechanisms and bringing out the role played by a myriad of actors, in addition to the Party-state, which maintains the key role as the final decision-maker, and well beyond the Ministry of Foreign Affairs (MFA) – the government agency that is officially responsible for State diplomacy – thus challenging the conventional wisdom that China is a unitary player in international affairs.

China's authoritarian political system gives the Party-state and its paramount leaders immense power in the making of policy, including foreign policy. Mao Zedong, Deng Xiaoping, and Xi Jinping are the three most powerful paramount leaders in the history of the PRC, and they have played a fundamental role in Chinese foreign policy over the years, contributing to transforming it from a revolutionary diplomacy to a developmental diplomacy, and then to a big-power diplomacy (Zhao 2020, 86). As Xi Jinping (2017) himself pointed out at the Nineteenth CCP National Congress in October 2017, while Mao made the Chinese people stand up (*zhan qilai* 站起来), and Deng made them prosper (*fu qilai* 富起来), he was going to make China strong (*qiang qilai* 强起来).

It was precisely by virtue of the fact that Mao was viewed as the 'saviour' of the country, who restored its long-desired sovereignty, unity, and independence and put an end to the notorious 'century of shame and humiliation' (*bainian chiru* 百年耻辱), that he always had the first and last word in all matters pertaining to both domestic and foreign politics. For Mao, in fact, there was no such thing as an insignificant matter in diplomatic affairs, and everything had to be

reported to and decided by the Central Committee. As such, the role of the Foreign Ministry, which was headed by Premier Zhou Enlai from 1949 to 1958, was defined as “keeping the central leadership well informed of China’s external situation and carrying out the central leadership’s decisions” (Chen 2001, 10-12).

Emerging from the chaos of the Cultural Revolution, Deng Xiaoping played a critical role in transforming the country by downsizing the role of ideology and placing a strong emphasis on the modernisation of the country’s economy and its opening up to the world, in order to transform China into an active member of the international community. Despite the fact that he was never the Party’s General Secretary/Chairman and held no other top government positions – he ‘only’ controlled the military as Chairman of the Central Military Commission –, he had great authority because of his personal stature, connections, and extensive experience. In terms of foreign policy decision-making, Deng’s model had much in common with the one used under Mao, as both shared a distinctly authoritarian characteristic. However, while power-making under Mao was characterised by vertical authoritarianism, under Deng it gradually evolved into a horizontal form (Zhao 1992). To replace the previous one-man model, Deng initiated a decentralisation process to delegate authority to the bureaucracy and sought to build a ‘collective leadership’ (*jiti juece* 集体决策)<sup>1</sup> with a group of senior leaders making decisions jointly, as Reform and Opening-up expanded the Chinese foreign policy agenda and brought an increasing number of players into the foreign policy decision-making process. Nonetheless, key national security decisions remained a privilege that was reserved for Deng personally.

When Xi Jinping arrived at Zhongnanhai and consolidated his power – by reducing the PBSC from nine to seven members, abolishing the term limit on his presidency, and eliminating his rivals through a harsh anti-corruption campaign – the ‘collective leadership’ quickly became a distant memory. In fact, Xi rapidly concentrated immense power in himself as the ‘core’ (*hexin* 核心)<sup>2</sup> of the leadership,<sup>2</sup> and immediately abandoned Deng’s low-profile diplomacy in favour of a pro-active big-power diplomacy with Chinese characteristics aimed at transforming the mission of PRC’s diplomacy, from setting a peaceful environment conducive to domestic development to one that pushes for the expansion of the country’s global reach, with the ultimate goal of achieving the so-called ‘China dream of the great rejuvenation

---

1 A truly collective leadership was only implemented after Deng’s retirement in the early 1990s. His successors did not have Deng’s personal authority, and thus played a role of *primus inter pares* among the members of the Politburo Standing Committee (PBSC) (Zhao 2020, 88).

2 A title assigned to Mao Zedong, Deng Xiaoping, and Jiang Zemin, but not to Hu Jintao.

of the Chinese nation' (*Zhonghua minzu weida fuxing de zhongguo meng* 中华民族伟大复兴的中国梦).

Much has been written about the process of centralisation of power in the hands of Xi Jinping. For the purposes of this essay, it is important to underline that this shift has contributed to the creation of a common global perception that the leadership of the CCP under Xi dictates the country's foreign policy agenda. This is true only in part, however: in fact, Chinese political decision-making is currently driven by a range of interests and shaped by different stakeholders. Thus, while Xi Jinping has accumulated enormous power comparable only to that of the 'Great Helmsman', there are other actors with varying degrees of autonomy and ability to intervene in the foreign policy decision-making process. In other words, while acknowledging the role of the CCP and its paramount leader in critical foreign affairs decisions, the reality is that such decisions are often the result of "seeking the broadest consensus among a myriad of actors" (Yu, Ridout 2021, 2).

The body of literature on China's pluralistic decision-making in foreign affairs is growing steadily, but it is still limited compared to the very many people who see China as a monolithic entity, due especially to the fact that the specificities of the Chinese system and the complexities of the decision-making process in Beijing's political establishment remain difficult to investigate, especially for non-Chinese speakers. The reality is actually quite different: China's approach to foreign policy became increasingly pluralistic under Deng Xiaoping, whose administration introduced landmark economic reforms that led to decentralisation across all types of policy-making at both the national and provincial levels. In particular, the new Constitution adopted in 1982 redefined the prerogatives of central and local governments and increased the agency of provinces in the Chinese political economy. A good example of this is the central government's decision to allow local governments to commit to large-scale investment projects without first receiving authorisation (Yu, Ridout 2021, 13). Consequently, many provinces, especially those on the coasts and borders, began to use their limited autonomy to engage directly with foreign governments and major multinational corporations, signing commercial agreements, attracting foreign investments, and enhancing their international profiles (Chen, Jian 2009, 6).

As a result of the PRC's increasing interdependence with the global arena and its growing foreign policy interests, the Chinese foreign policy decision-making process has seen the emergence of a plurality of actors who want their voices to be heard and to attempt to influence the top leadership's decisions. This list includes both governmental and non-governmental actors, from Leading Small Groups

(LSGs)<sup>3</sup> to various ministries, and from the business sector – mainly energy companies and financial institutions – to research groups, think tanks, netizens, and NGOs, resulting in a “cacophony of voices” (Jakobson, Knox 2010, vi). In this process, while the Communist Party, in particular its highest body (the Politburo Standing Committee), has retained the ultimate decision-making power, the MFA has confirmed its “secondary role” as merely one actor “among others”, and not necessarily the most important (Jakobson, Knox 2010, VI).

Owing to space limitations, this essay will deal with only the most relevant new actors (sub-national governments, businesses, research institutes and think tanks, and netizens), and reflect on the growing marginalisation of the MFA to the benefit of other ministries and government agencies. Finally, it will seek to reflect on the dysfunctions that the presence of so many actors and voices might cause in Chinese foreign policy decision-making and assess the current situation, which sees China as a world superpower that wishes to secure a growing say in global governance.

## 2      **The Emergence of New Players in the Foreign Policy Decision-Making Process**

In his 2013 study on how China is walking the path towards becoming a major power, David Shambaugh (2013, 62) identified five concentric circles in Chinese foreign policy decision-making that have emerged in recent decades: senior leader, ministries, intelligence and research institutions, local governments and corporations, and society. More specifically, other scholars have distinguished between traditional and non-traditional actors or governmental and non-governmental actors (Jakobson, Knox 2010; Hao, Su 2005, 20; Lanteigne 2019, ch. 2). The former include the top leadership – namely, the PBSC, the State Council ministries, and the People’s Liberation Army (PLA), which coincides with Shambaugh’s first two circles – while the latter refers to sub-national governments (provinces and metropolitan cities with provincial status), business entities (the powerful State-Owned Enterprises, SOEs), research institutions and think tanks, and well-informed, and increasingly active, social groups and netizens.

As far as sub-national governments are concerned, in addition to the above, there is a vast body of literature that recognises the role played by provinces and cities with provincial status in the formulation and implementation of important foreign affairs-related

---

**3** LSGs (*lingdao xiaozu* 领导小组) are *ad hoc* bodies of the CCP charged with decision-making in major functional issue areas that since the 1950s have operated effectively as inter-agency executive committees, cutting across government, the Party, and military systems.

policies. In particular, Audrye Wong (2018) has identified three main mechanisms of influence in order to show the extent to which provincial-level governments are able to influence the formulation and implementation of foreign policy – carpetbagging, resisting, and trailblazing –, and uses important case studies focussing on Shanghai, Yunnan, and Shaanxi to demonstrate how local governments shape foreign policy through the economy, security, and soft power respectively. Many coastal and border provinces are particularly active in some of the most relevant areas of Beijing’s foreign policy agenda, as demonstrated by the research carried out by both Chinese and Western scholars on the African continent and in the Arctic, South-East Asia, and the BRI, where sub-national governments play a significant role as traders, project builders, investors, and aid providers (Chen, Jian 2009; Duggan 2020; Kossa 2020; Hao, Su 2005, chs 9-10; Summers 2021). Provincial governments are also active in conducting informal diplomacy, especially with those countries with which China has no formal diplomatic relations, or where high-level contacts have been suspended (Lampton 2001, 105; Zhao 2020, 105).

Other new key stakeholders in Beijing’s foreign policy formulation and implementation are the centrally-controlled SOEs, whose involvement in foreign policy ranges from BRI investments to provocative initiatives in the South China Sea (SCS) (Yu, Ridout 2021, 3). While the conventional wisdom is that these enterprises are acting on behalf of the central state, the reality is that their commercial interests do not always coincide with the state’s agenda (3). A good example of this is the role played by the largest Chinese oil companies – Sinopec, the China National Petroleum Corporation, and the China National Offshore Oil Corporation –, which have consistently blocked Beijing’s efforts to form a Ministry of Energy (Downs 2012). Similarly, China’s five largest utility companies (in terms of assets and installation capacity), which are also known as the ‘Big Five’,<sup>4</sup> have vehemently resisted setting carbon emission quotas in the past because they would have been detrimental to their interests. Furthermore, their reluctance to cooperate with Beijing over setting emission targets has slowed the delivery of the PRC’s domestic climate policy agenda (Yu, Ridout 2021, 10-11), and risks compromising Xi Jinping’s commitment to make China carbon neutral by 2060. In other cases, they have opposed Beijing’s joining the United Nations and other countries in the application of sanctions against specific countries (Iran and North Korea), since any sanctions would hurt their commercial interests (Zhao 2020, 105). In recent years, the interests of China’s SOEs have also begun to diverge from those of the Party. It

---

<sup>4</sup> The Huaneng Group, the Huadian Group, the China Energy Investment Corporation, the State Power Investment Corporation and the Datang Group.

is worth mentioning here that SOEs have an unusual structure: they are a hybrid between a corporate organisation and a government ministry, and their leaders are appointed to a rank equivalent to a State Council minister or provincial governor, which partly explains why their relationships to the Party and/or the central government apparatus are not submissive (Yu, Ridout 2021, 9-13).<sup>5</sup>

With China's expanding global diplomatic network and the increasingly complex nature of its international relations, Chinese Party-state leaders began to feel the need to have more information, analysis, and advice in order to be able to correctly 'assess, advance, and safeguard' the country's interests. In fact, many ministries lacked the appropriate expertise to deal with the challenges that had accompanied the active international expansion of Chinese activities. They therefore increasingly turned to research institutions and academia for consultation (Jakobson, Knox 2010, 34). The public and internal writings of academics and intellectuals may not only offer expertise on specific issue areas. Still, they can also provide a window through which foreign ideas and international and domestic debates are channeled to top decision-makers. Two volumes published in 2019 offer exciting insights into the influence exerted by scholars - in particular, International Relations (IR) scholars - in the decision-making process of Chinese foreign policy.<sup>6</sup> According to Feng Huiyun, He Kai, and Yan Xuetong (2019, 4), there is no causal and linear link between Chinese IR scholars and policy-makers. Instead, they suggest the existence of at least four different types of relationships between the two parties and propose four models to theorise the potential roles that Chinese IR scholars can play in formulating the country's foreign policy. These four models are the epistemic community model, the 'free market' model, the signaling policy model, and the mirroring policy model. In the first model, scholars may actively influence China's foreign policy as part of an epistemic community. In the second, scholars may provide intellectual products in a free market of ideas that policy-makers can refer to when making decisions. In the third model, scholars may play a policy-signaling role in facilitating the government's test of controversial ideas before the formalisation and adoption of new policies. Finally, in the fourth, scholars can serve as a mirror to reflect the underlying transformations of Chinese foreign policies and domestic politics as well (Feng, He, Yan 2019, 9-15).

---

**5** A case in point is offered by Lee Jones and Zou Yizheng (2017) and concerns the China Power Investment Corporation and its Myitsone hydroelectric dam project in Myanmar. In this case, a central SOE has clearly challenged and subverted central regulations, to the detriment of Sino-Myanmar state relations.

**6** See Feng, He, Yan 2019 and Feng, He, Li 2019.

With regard to think tanks, while the PRC has renowned research institutes dating back to the Maoist and early Denghist eras, the use of the term *zhiku* 智库 ('think tank') to refer to policy research centres and institutes has gained popularity in fairly recent times, more precisely since Xi Jinping called for building "Chinese-style think tanks". The "Decision of the Central Committee of the Communist Party of China on Some Major Issues Concerning Comprehensively Deepening the Reform" adopted at the Third Plenary Session of the Eighteenth Central Committee of the CCP on 12 November 2013 called for strengthening a "new style think tank with Chinese characteristics" (*Zhongguo tese xinxing zhiku* 中国特色新型智库) and improving the policy advisory system.<sup>7</sup> This was the first time the term 'think tank' had been mentioned in an official document, and in response to the call, all the leading research institutes and think tanks in the country engaged in a process of 'modernisation', with the ultimate goal of transforming themselves into "high-level quality research institutes with considerable international influence" (Menegazzi 2021, 2).

It is important to underline the fact that most of the important foreign policy think tanks in China – such as the Chinese Academy of Social Sciences (CASS), the China Institutes of Contemporary International Relations (CICIR), and the China Institute of International Studies (CIIS) – have always operated, and continue to operate, within the bureaucratic hierarchy, and are administered by CCP organs, the State Council, ministries, or the PLA (Jakobson, Knox 2010, 38).<sup>8</sup> This has important implications, because their government affiliations and orientations limit their ability to provide objective policy recommendations, especially where the research results go against official policy views. It may be superfluous to highlight the fact that genuinely independent think tanks (in a Western sense) cannot exist in an authoritarian state like the PRC because the public dissemination of what the authorities consider to be unsanctioned thought is not tolerated (Jakobson, Knox 2010, 39). This lack of autonomy represents the most significant limitation for Chinese think tanks (Godement et al. 2016), despite a proliferation that has led some observers to refer to a "golden age" of think tanks (Tang 2014), and a general recognition of their important role in Chinese foreign policy. Along with their traditional activities – submitting internal reports and references to the top leadership and Party-state agencies, and presenting in-person advice through lectures and briefings –, they host a myriad of public

---

<sup>7</sup> Cf. <https://china.usc.edu/decision-central-committee-communist-party-china-some-major-issues-concerning-comprehensively>.

<sup>8</sup> In more recent years, non-governmental think tanks have also emerged, but they have sought to undertake research projects commissioned by the government and to serve the government's needs. The most influential among them is the Center for China and Globalization (CCG).



events, organise conferences and activities, and attend high-level forums and summits, thereby contributing towards greatly enhancing China's public diplomacy (Menegazzi 2021, 13-14, 16). In this sense, they are emerging as essential actors in Chinese foreign policy and diplomatic practices, as revealed by numerous studies that focus on the role played by think tanks both in general (Shambaugh 2002; Zhu 2013; Abb 2015; Menegazzi 2018; Tan, Li 2018) and, in particular, on specific issues and regions (Liao 2006; Hua 2017).

At present, China is near the top of the world ranking for the number of think tanks (1,413), surpassed only by the US (2,203) (McGann 2021, 44), and some figure in the list of the top ten and top twenty think tanks in the annual *Global Go To Think Tank Index Report* published by James McGann. In the most recent *Report*, which came out in January 2021, the CICIR ranked 9th in the "Top Think Tanks Worldwide" (which does not take the US into account), and 18th in the list that includes the US; the CASS ranked 24th in the first list and 38th in the second (McGann 2021, 55, 64).

As for netizens, it is an undeniable fact that both the media revolution that has taken place in the country over the past 40 years, and the spread of Internet use among the Chinese public over the past two decades have substantially transformed the way Chinese citizens and their rulers communicate in general. In fact, while the media were previously a tool that was exclusively available to officials, with the advent of the Internet, interest groups and citizens can also use the media and the Internet to influence both public opinion and each other. In December 2020, the PRC had the world's largest number of Internet users - 988.89 million - and 60% of Internet penetration; at the same time, it had 731 million online news consumers, with 726 million accessing news on their mobile devices (Lai Lin 2022; *Xinhua* 2020). The dramatic spread of use of the Internet has greatly accelerated the speed at which both domestic and international news reaches ordinary citizens. The new instruments adopted by Chinese leaders and institutions to communicate with international and domestic audiences (especially the state-backed press and its Facebook and Twitter accounts)<sup>9</sup> have contributed towards amplifying the spread of information. That said, it must be underlined that even though the Internet does not affect the foreign policy decision-making process directly (Yang 2016), the Chinese authorities have started to make "listening to the public" a regular procedure (Hong 2016, 98), as ordinary citizens are increasingly voicing their opinions on the Internet. This is

---

<sup>9</sup> Despite their ban in China, the importance of both Facebook and Twitter in the Chinese media sphere is enormous. The Chinese public accesses them via Virtual Private Networks (VPNs) or through the highly popular social media platforms WeChat and Weibo, where tweets summarising official press conferences or other important events are widely shared.

especially true for specific areas of the Chinese foreign policy agenda, such as North Korea (Scobell et al. 2019), the two Koreas (Gries 2012), the US (Zhang, Xiao 2018), and nationalism directed at (but not limited to) Japan (Shen, Breslin 2010). In fact, the Chinese government is careful when it comes to considering the mood of the Chinese people, which is largely expressed through the Internet, riding the wave in some cases, and blocking expressions of anger in others where they might harm the country's interests, with an awareness that dissatisfaction within society might give cause the Party's ability to govern to be questioned (Jakobson, Knox 2010, 41-6).

### **3 The Marginalisation of the Ministry of Foreign Affairs**

Following globalisation and the increase in China's international activities, nearly every ministry in the Chinese state system has developed some form of interest in foreign affairs. Jakobson and Manuel (2016, 105), for instance, have reported the example of maritime affairs, which in the last few decades has attracted attention from the Ministry of Public Security (MPS), the Ministry of National Defence, the Fishery Administration under the Ministry of Agriculture and Rural Affairs, the State Oceanic Administration under the Ministry of Land and Resources (MLR), the Maritime Safety Administration under the Ministry of Transport (MOT), the Ministry of Ecology and Environment, the General Administration of Customs, the Ministry of Science and Technology (MST), the National Tourism Administration, the Ministry of Industry and Information Technology, and, ranked above them all, the National Development and Reform Commission, which is responsible for economic development in general and resources in particular. To this long list they also add the Ministry of State Security (MSS) and the State-owned Assets Supervision and Administration Commission, which oversees the major state-owned enterprises, including oil companies. Other authors have focussed on the prominent role played by the Ministry of Commerce (MOFCOM) compared to other ministries (starting from the MFA) and national commissions on specific issues (foreign trade negotiations, development assistance) or particular regions. As reported by Yu Jie and Lucy Ridout (2021, 7), bureaucratic disputes frequently erupt over development assistance between the MOFCOM, as the executor of development projects, and the MFA, the chief implementer of the PRC's foreign policy, each of which adopts its own specific point of view when proposing new development assistance projects or loans. Indeed, the Chinese aid system is characterised by persistent fierce competition involving not only the two ministries concerned, but also the Ministry of Finance and

the companies responsible for implementing Chinese aid projects (Zhang, Smith 2017; Varral 2016).<sup>10</sup>

In Africa, the MOFCOM plays a far more influential role than the MFA when it comes to dealing with the direction of Beijing's foreign policy towards the continent. In general, the former has 'usurped' some of the MFA's traditional responsibilities. This is especially true in the case of the disbursement of concessional loans (Corkin 2011, 68). Similarly, in the Arctic, the MFA is only 'one' of the ministries in a leading position to coordinate and represent China's Arctic endeavours. In addition to the Ministry of Natural Resources (MNR) - formerly the State Oceanic Administration under the now-defunct MLR -, many other ministries and agencies strive for influence in the region, from the MST to the MOFCOM, and from the MOT to the China Meteorological Administration (CMA). No less important is the growing role played by the PLA and its navy (Kossa 2020, 27).

One of the reasons behind the MFA's diminishing and diluted authority over the past few decades is the lack of political status accorded to the State Councillor for Foreign Affairs. In fact, the specialisation and professionalisation process required by the reform policy has led to a paradoxical reduction of the political status (Zhao 2020, 96). During the eras of Jiang Zemin and Hu Jintao, the Foreign Minister (FM) was reduced from being a member of the Politburo and Vice-Premier to just Vice-Premier and a State Councillor. After many years of decline, however, the political status of the FM was finally enhanced, at least symbolically, with the promotion of Yang Jiechi - China's top-ranking career diplomat - to the Politburo in October 2013. Yang was the first former FM to reach this level in two decades. Wang Yi, the current FM, was also appointed as a State Councillor at the annual session of the National People's Congress (NPC) in March 2018 - another first in decades (Zhao 2020, 96). Both appointments were fairly closely aligned with Xi Jinping's vision of consolidating foreign policy decision-making at the top level of the Party. Reforms of the MFA began in early 2017, and were encouraged to "forge a politically resolute, professionally exquisite, strictly disciplined foreign affairs corps", and to create a more empowered diplomatic corps and a more consolidated diplomatic structure that more effectively represented China's interests "with one voice" as the country approached the centre of the world stage (Zhao 2020, 97). The aim of centralising the foreign policy decision-making process was to give the CCP and Xi Jinping himself

---

<sup>10</sup> According to Kishan Rana (2019, 203), tensions between the MOFCOM and the MFA were also behind the decision in 2018 to create a specific agency to strengthen the strategic planning and overall coordination of foreign aid: the China International Development Cooperation Agency (CIDCA).

greater control to “provide strong support for opening new horizons in China’s diplomacy” (Onnis 2019, 46; Wang 2017), and it began with the establishment of an unprecedented National Security Commission (NSC) in April 2014, chaired by Xi, which has the purpose of solving the coordination problems of both domestic and foreign policy decision-making. It continued in 2018 with the upgrading of the Foreign Affairs Leading Small Group (FALSG) (*Zhongyang waishi gongzuo lingdao xiaozu* 中央外事工作领导小组), headed by Xi, to Central Foreign Affairs Commission (*Waishi weiyuanhui* 外事委员会). It may be helpful to remember that the FALSG was set up in its prior form at the beginning of the 1980s with the precise goal of coordinating China’s often disjointed foreign policy. Its general office, which was located inside the MFA, was reportedly often bypassed by other government agencies because it was seen as low-ranking and ineffective, and the group appeared to be incapable of coordinating China’s foreign policy. The ministry had been troubled for many years by its inability to conduct its affairs coherently due to the presence of multiple actors seeking to influence foreign policy. With its new moves, the leadership sent a clear message that the Party alone controlled China’s foreign affairs and that it would not tolerate actions that might compromise efforts to realise the China dream by means of the steps represented by the so-called ‘two centenaries’ (*liangge yibainian* 两个一百年), with special reference to the second, aimed at making the country a ‘strong, democratic, civilised, harmonious, and modern socialist country’ by 2049, the centenary of the PRC. Paradoxically, a process that had been initiated to strengthen the foreign policy decision-making process, and especially the ministry in charge of it, ended up by marginalising the MFA even further. In fact, as summit diplomacy has become more and more frequent, senior leaders (*Xi in primis*) have themselves become foreign ministries (Zhang 2016, 454), thus contributing to the diminishment of diplomats (Sun 2016).

#### 4 Conclusions

The Chinese foreign policy decision-making system has a contradictory dual nature: it is excessively centralised and vertically hierarchical on the one hand, and pluralistic and chaotic on the other. It is in this second aspect that, according to some authors (Jakobson 2013; Jakobson, Manuel 2016), lies the heart of the problems with the PRC’s foreign policy decision-making, which might be termed ‘fragmented authoritarianism’. According to this model, authority is divided and fragmented just one level below the top of the Chinese political system, and because of this fragmentation, actors in the decision-making process are encouraged to seek a consensus to reach a conclusion,

which requires them to engage in long and sometimes strenuous bargaining (Lieberthal, Lampton 1995, 8).<sup>11</sup>

Two decisions, taken at the end of 2012 by the MPS and Hainan Provincial Government, respectively, offer a good example of the dysfunctions that this 'cacophony of voices' causes in Chinese decision-making. They also underline the damage that a single government entity can cause to China's international relations and reputation (Jakobson 2013, 14). On 26 November 2012, the MPS issued new passports with maps that included disputed islands and territories as Chinese territory without first consulting the MFA. This led to serious tensions between the two ministries. A few days later, without asking for central government approval, the Hainan Provincial Government announced that China's maritime law enforcement vessels would stop and search ships in the disputed areas of the SCS. These cases clearly show that despite the highly-centralised Chinese foreign policy structure, with its traditional decision makers (the Politburo and its Standing Committee) still representing the pinnacle of political power, non-traditional actors represent a reality that cannot be neglected, since they struggle to make their voice heard, and their actions can sometimes provoke diplomatic incidents that can be detrimental to the country's interests.

In conclusion, in response to those scholars who emphasise the new personalism embedded in Xi Jinping's posture and the return of personalistic rule in Chinese policy-making (Shirk 2018), there are others who point out that he simply cannot lead as Mao and Deng did because of the dramatic changes that have taken place in China's foreign relations (Zhang 2016, 452) and its foreign policy decision-making process.

---

**11** In a recent publication on the role of interest groups in China's foreign policy, Xu Yanzhuo rejects the notion that there is any bargaining at all in the foreign policy decision-making, while recognising that "more actors have varying degrees of autonomy and capacity to intervene in the foreign policy process through policy briefing reports and implementation processes" (Xu 2022, 53).

## Bibliography

- Abb, P. (2015). "China's Foreign Policy Think Tanks: Institutional Evolution and Changing Roles". *Journal of Contemporary China*, 24(3), 531-53.
- Breslin, S. (ed.) (2021). *China Risen? Studying Chinese Global Power*. Bristol: Bristol University Press.
- Chen, J. (2001). *Mao's China and the Cold War*. Chapel Hill; London: The University of North Carolina Press.
- Chen, Z.; Jian, J. (2009). "Chinese Provinces as Foreign Policy Actors in Africa". *South African Institute of International Affairs*, 22, 1-22.
- Christensen, T. (2012). "More Actors, Less Coordination? New Challenges for the Leaders of a Rising China". Rozman, G. (ed.), *China's Foreign Policy: Who Makes It, and How Is It Made?*. New York: Palgrave Macmillan, 21-37.
- Corkin, L. (2011). "Redefining Foreign Policy Impulses Towards Africa: The Roles of the MOFA, the MOFCOM and China Exim Bank". *Journal of Current Chinese Affairs*, 40(4), 61-90.
- Doak Barnett, A. (1985). *The Making of Foreign Policy in China*. London: I.B. Tauris.
- Downs, E.S. (2007). "Business Interest Groups in Chinese Politics: The Case of the Oil Companies". Li, C. (ed.), *China's Changing Political Landscape: Prospects for Democracy*. Washington: The Brookings Institution Press, 121-41.
- Duggan, N. (2020). "Chinese Foreign-Policy Actors in Africa". Duggan, N., *Competition and Compromise Among Chinese Actors in Africa: A Bureaucratic Politics Study of Chinese Foreign Policy Actors*. Singapore: Palgrave Macmillan, 103-48.
- Feng, H.; He, K.; Li, X. (2019). *How China Sees the World: Insights From China's International Relations Scholars*. Singapore: Palgrave Macmillan.
- Feng, H.; He, K.; Yan, X. (eds) (2019). *Chinese Scholars and Foreign Policy: Debating International Relations*. Abingdon; Oxon: Routledge.
- Glaser, B.S. (2012). "Chinese Foreign Policy Research Institutes and the Practice of Influence". Rozman, G. (ed.), *China's Foreign Policy: Who Makes It, and How Is It Made?*. New York: Palgrave Macmillan, 87-124.
- Godement, F.; Doyon, J.; Stanzel, A.; Vasselier, A. (2016). "A Hundred Think Tanks Bloom in China", monogr. no., *China Analysis*, August. London: European Council on Foreign Relations. [https://ecfr.eu/wp-content/uploads/hundred\\_think\\_tanks.pdf](https://ecfr.eu/wp-content/uploads/hundred_think_tanks.pdf).
- Gries, P.H. (2012). "Disillusionment and Dismay: How Chinese Netizens Think and Feel About the Two Koreas". *Journal of East Asian Studies*, 12(1), 31-56.
- Hao, Y.; Su, L. (eds) (2005). *China's Foreign Policy Making: Societal Force and Chinese American Policy*. London; New York: Routledge.
- Hong, J. (2016). "The Internet and China's Foreign Policy Making: The Impact of Online Public Opinions as a New Societal Force". Hao, Y.; Su, L. (eds), *China's Foreign Policy Making: Societal Force and Chinese American Policy*. London: Routledge, 93-109.
- Hua, X. (2017). "Chinese Think Tanks' Influence on Foreign Policy Making: A Case Study of the Role of CIIS and SIIS in the Making of China's Europe Policy". Abelson, D.; Brooks, S.; Hua, X. (eds), *Think Tanks, Foreign Policy and Geo-Politics: Pathways to Influence*. London: Routledge, 132-53.
- Jakobson, L. (2013). *China's Foreign Policy Dilemma*. Lowy Institute for International Policy. <http://www.jstor.org/stable/resrep10137>.
- Jakobson, L.; Knox, D. (2010). "New Foreign Policy Actors in China". *SIPRI Policy Papers*, 26.

- Jakobson, L.; Manuel, R. (2016). "How Are Foreign Policy Decisions Made in China?". *Asia & Pacific Policy Studies*, 3(1), 101-10.
- Kossa, M. (2020). "China's Arctic Engagement: Domestic Actors and Foreign Policy". *Global Change, Peace & Security*, 32(1), 19-38.
- Lai Lin, T. (2022). "Number of Internet Users in China from 2008 to 2021". *Statista*, 12 May. <https://www.statista.com/statistics/265140/number-of-Internet-users-in-china>.
- Lampton, D.M. (ed.) (2001). *The Making of Chinese Foreign and Security Policy in the Era of Reform, 1978-2000*. Stanford: Stanford University Press.
- Lanteigne, M. (2019). *Chinese Foreign Policy: An Introduction*. London: Routledge.
- Lee, J.; Zou, Y. (2017). "Rethinking the Role of State-Owned Enterprises in China's Rise". *New Political Economy*, 22(6), 743-60.
- Liao, X. (2006). *Chinese Foreign Policy Think Tanks and China's Policy Towards Japan*. Hong Kong: The Chinese University Press.
- Lieberthal, K.G.; Lampton, D. (eds) (1995). *Bureaucracy, Politics, and Decision Making in Post-Mao China*. Berkeley: University of California Press.
- Lu, N. (1997). *The Dynamics of Foreign-Policy Decision-Making in China*. Boulder: Westview Press.
- Martin, P. (2021). *China's Civilian Army: The Making of Wolf Warriors*. Oxford: Oxford University Press.
- McGann, J.G. (2021). "2020 Global Go To Think Tank Index Report". *TTCSP Global Go To Think Tank Index Reports*, 18. [https://repository.upenn.edu/cgi/viewcontent.cgi?article=1019&context=think\\_tanks](https://repository.upenn.edu/cgi/viewcontent.cgi?article=1019&context=think_tanks).
- Menegazzi, S. (2018). *Rethinking Think Tanks in Contemporary China*. Basingstoke: Palgrave.
- Menegazzi, S. (2021). "Chinese Think Tanks and Public Diplomacy in the Xi Jinping Era". *Global Society*, 35(3), 1-22.
- Onnis, B. (2019). "China's Foreign Policy 2018: Implementing the China Dream". Torri, M.; Mocci, N. (eds), *Reacting to Donald Trump's Challenge*, monogr. no., *Asia Maior*, 29, 43-68.
- Rana, K.S. (2019). "China's Foreign Ministry: Fit for Purpose in the Era of Xi Jinping, BRI and 'Major Country Diplomacy with Chinese Characteristics'?" *China Report*, 55(3), 193-218.
- Rozman, G. (ed.) (2012). *China's Foreign Policy: Who Makes It and How It Is Made?*. New York: Palgrave MacMillan.
- Scobell, A.; Beauchamp-Mustafaga, N.; Cevallos, A.; Chan, A.; Winkelman, Z. (2019). "Netizen Opinion and China's Foreign Policy: Interpreting Narratives About North Korea on Chinese Social Media". *Asia Policy*, 14(3), 97-122.
- Shambaugh, D. (2002). "China's International Relations Think Tanks: Evolving Structure and Process". *The China Quarterly*, 171, 575-96.
- Shambaugh, D. (2013). *China Goes Global*. Oxford; New York: Oxford University Press.
- Shambaugh, D. (ed.) (2020). *China & the World*. Oxford; New York: Oxford University Press.
- Shen, S.; Breslin, S. (eds) (2010). *Online Chinese Nationalism and China's Bilateral Relations*. Lanham: Lexington Books.
- Shirk, S.L. (2018). "China in Xi's 'New Era': The Return to Personalistic Rule". *Journal of Democracy*, 29(2), 22-36.
- Summers, T. (2021). "The Belt and Road Initiative in Southwest China: Responses from Yunnan Province". *The Pacific Review*, 34(2), 206-29.

- Sun, J. (2016). "Growing Diplomacy, Retreating Diplomats: How the Chinese Foreign Ministry Has Been Marginalized in Foreign Policy-Making". *Journal of Contemporary China*, 26(105), 419-33.
- Tan, R.; Li, H. (2018). "Internationalisation of Think Tanks: Progress and Challenges in China". *China: An International Journal*, 16(2), 51-66.
- Tang, Y. (2014). "Golden Age of Think Tanks". *Beijing Review*, 22. [http://www.bjreview.com/nation/txt/2014-05/27/content\\_621020\\_3.htm](http://www.bjreview.com/nation/txt/2014-05/27/content_621020_3.htm).
- Varrall, M. (2016). "Domestic Actors and Agendas in Chinese Aid Policy". *The Pacific Review*, 29(1), 21-44.
- Wang, S. (2017). "Xi Jinping's Centralization of Chinese Foreign Policy Decision-Making Power". *East Asian Policy*, September, 34-42.
- Wong, A. (2018). "More than Peripheral: How Provinces Influence China's Foreign Policy". *The China Quarterly*, 235, 735-57.
- Xi, J. (2017). "Secure a Decisive Victory in Building a Moderately Prosperous Society in All Respects and Strive for the Great Success of Socialism with Chinese Characteristics for a New Era". Delivered at the Nineteenth National Congress of the Communist Party of China, 18 October. [http://www.xinhuanet.com/english/download/Xi\\_Jinping's\\_report\\_at\\_19th\\_CPC\\_National\\_Congress.pdf](http://www.xinhuanet.com/english/download/Xi_Jinping's_report_at_19th_CPC_National_Congress.pdf).
- Xinhua (2020). "China Has 731 Mln Users of Online News Services: Report". *Xinhua*. [http://www.xinhuanet.com/english/2020-05/05/c\\_139031614.htm](http://www.xinhuanet.com/english/2020-05/05/c_139031614.htm).
- Xu, Y. (2022). "China's Decision-Making System and Interest Groups". Berkofsky, A.; Sciorati, G. (eds), *China's Foreign Policies Today: Who Is in Charge of What*. Milan: LediPublishing, 53-67.
- Yang, Y. (2016). "The Internet and China's Foreign Policy Decision-Making". *Chinese Political Science Review*, 1, 353-72.
- Yu, J.; Ridout, L. (2021). *Who Decides China's Foreign Policy? The Role of Central Government, Provincial-Level Authorities and State-Owned Enterprises*. Briefing Paper. Asia-Pacific Programme. London: Chatham House, the Royal Institute of International Affairs. <https://www.chathamhouse.org/sites/default/files/2021-10/2021-11-01-who-decides-chinas-foreign-policy-jie-et-al.pdf>.
- Yun, S. (2013). *Chinese National Security Decision-Making: Processes and Challenges*. Washington, D.C.: The Brookings Institutions. <https://www.brookings.edu/wp-content/uploads/2016/06/chinese-national-security-decisionmaking-sun-paper.pdf>.
- Zhang, C.; Xiao, C. (2018). "How Do Chinese Netizens View the US-China Trade War?". *The Diplomat*, 2 November. <https://thediplomat.com/2018/11/how-do-chinese-netizens-view-the-us-china-trade-war>.
- Zhang, D.; Smith, G. (2017). "China's Foreign Aid System: Structure, Agenda, and Identities". *Third World Quarterly*, 38(10), 2330-46.
- Zhang, Q. (2016). "Bureaucratic Politics and Chinese Foreign Policy-Making". *The Chinese Journal of International Politics*, 9(4), Winter, 435-58.
- Zhao, Q. (1992). "Domestic Factors of Chinese Foreign Policy: From Vertical to Horizontal Authoritarianism". *The ANNALS of the American Academy of Political and Social Science*, 519(1), 158-75.
- Zhao, S. (2020). "China's Foreign Policy Making Process". Shambaugh, D. (ed.), *China & the World*. Oxford; New York: Oxford University Press, 85-110.
- Zhu, X. (2013). *The Rise of Think Tanks in China*. New York: Routledge.
- Zhu, Z. (2020). *A Critical Decade: China's Foreign Policy (2008-2018)*. Singapore: World Scientific.



### The Historian's Gaze

Essays on Modern and Contemporary China  
in Honour of Guido Samarani

edited by Laura De Giorgi and Sofia Graziani

# The Wisdom of Senses. Neo-Confucian Reflections on Cultural Body

Paolo Santangelo

Sapienza Università di Roma, Italia

**Abstract** Sensory experiences are not passive feelings limited to the body or part of it, but influence the concept of the self, and play epistemological and aesthetic functions. This essay presents a few significant examples of the exploration of sensorial functions in the ambit of Neo-Confucian philosophical and moral texts. The examples show a holistic approach, and above all explore the 'legitimation' of senses in the *li-qi* 理-氣 discussion or their role in the self-cultivation process.

**Keywords** Cultural body. Neo-Confucianism. Moral intuition. Sensorial perception. Emotions.

**Summary** 1 Body, Self and Feelings. – 2 Mind and Sensory Organs. – 3 Zhang Zai. – 4 Zhu Xi. – 5 Li Zhi. – 6 Wang Fuzhi. – 7 Yan Yuan. – 8 Dai Zhen.

## 1 Body, Self and Feelings

In the studies on emotions and states of mind, the cultural role of the body and the senses is an important topic. Sensory experiences are not passive feelings limited to the body or part of it, but influence the concept of the self, and play epistemological and aesthetic functions. The rich lexicon of bodily sensations enriches the language of literary descriptions, medical and criminal texts, and is also used in philosophical and moral treatises. Literary sources are very useful for understanding sensorial perceptions, as they document myths, songs, poems, and legends that accompany various senses; they show how sensory reactions become passions, beliefs, stimulation for solidari-



Edizioni  
Ca' Foscari

### Sinica venetiana 10

e-ISSN 2610-9042 | ISSN 2610-9654

ISBN [ebook] 978-88-6969-723-4 | ISBN [print] 978-88-6969-724-1

#### Peer review | Open access

Submitted 2022-07-26 | Accepted 2022-12-07 | Published 2023-10-11

© 2023 Santangelo | © 4.0

DOI 10.30687/978-88-6969-723-4/011

ty, exclusion, self-cultivation, love and hate.<sup>1</sup> Owing to the limitation of space allowed, this essay presents a few significant examples of their exploration in the ambit of Neo-Confucian thinkers.

The previous studies dealing with the 'cultural body' and the representation of sensorial functions have mainly concentrated on some aspects or specific topics, such as religious thought, Daoist theory and practices, and medicine. After the pioneering work by Geaney (2002), studies dedicated to sensorial experiences from psychological and anthropological perspectives have increased considerably, thanks to the growing awareness of the symbolic and imaginative value of the sensory function, consolidated among contemporary scholars, who recognise the role of the senses in the ethical, aesthetic and social fields. Those researches concerning the history of ideas have highlighted the different orientations of Chinese writers, aimed at an ethical perspective compared with Western scientists and Jesuits (Meynard 2020). These findings are undoubtedly considerable, but further studies should be made to examine overall the peculiar contribution of Chinese thought - and Neo-Confucianism in particular - on the role of the body in the whole world view, the relationship with human nature, values and the symbolic meanings attributed to it. Such a contribution would be necessary not only in the light of the progress of new disciplines, such as neurosciences and biosociology, but because it would bring new light to the intersection of the various subjects and knowledge areas, in addition to those mentioned, including the practices of self-cultivation, physiognomy, cosmology, philosophical thought. I tried this path through a few specific textual analyses of the representation of specific sensory experiences, and key terms, such as *xiang* 香 ('aroma', incense and its metaphorical use) in the literary production of late imperial China (Santangelo, Middendorf 2006; Santangelo 2014; 2018; 2019). Deep enquiries concerning embodied moral psychology and cognition of Confucian philosophy and the bodily foundations of early Confucian virtues have appeared in the last decades (among them, Seok 2013; Csikszentmihalyi 2004). Moreover, besides philosophical analyses of Confucian and Neo-Confucian vision of the body (on Neo-Confucian vision see Yang 1996, 293-412), new studies on the modern and contemporary periods have been published, but they mainly explore the space-timed perception of senses in the life of great urban settings through the analysis of narrative texts of contemporary urban fictions (Møller-Olsen 2021), or the use of sensorial means and communication in media, art, music, theatrical performances and literature (Wu, Huang 2022).

---

**1** On a psychological level, the reader may re-live personal or others' past experiences, and from an anthropological perspective, the analysis of the descriptions of these experiences is useful for cross-cultural studies, to understand what is universal and what specifically inherent to a certain society and time. For the importance of literary and theatre sources, see Balaban 2012.

It is evident that the implications in the description of the sensory experiences and perceptions of the body are innumerable. The present essay can merely afford an essential analysis of the thought of a few thinkers, highlighting the characteristics of the Neo-Confucian exploration of the senses by examining the constants in their representation, through some significant examples of the evolution of Neo-Confucianism. This preliminary study offers some ideas for further research that help to open up new spaces in this field.

## 2 Mind and Sensory Organs

The philosophical discussion on sensory experiences revolved around moral questions, and since the beginning of Confucian thought, sensitive knowledge was examined from an ethical perspective. Mencius and especially Xunzi laid the foundations for future discussions: according to Xunzi 荀子 (300-230 BC), the effects of desiring and loathing were produced by senses owing to their hedonistic and vitalistic motivations.<sup>2</sup> Mencius focussed on the relationship between senses and desires but contrasted these “inferior” natural tendencies with the “superior” virtues of heavenly morality (*ming* 命).<sup>3</sup> In the following centuries, notwithstanding the changes of perspective due for instance to the Buddhist influence, the “organs/functions of the senses” (*guan* 官) continued to be supposed to work under the direction of the heart-mind (*xin* 心) as ruler (*jun* 君).<sup>4</sup> The sensory experiences have been closely associated with theories of knowledge, motivation, desire and emotion, medical theory and practice, and sexual cultivation, but fundamentally the double implication of social and moral effects of the senses remained the basis of the debate on them.<sup>5</sup>

A practical reflection, connecting the senses with human nature, their function towards the heart-mind, and their role in the basic hedonistic tendencies of humans, was inherited by Neo-Confucians.

<sup>2</sup> In his analysis on the basic functions of sensory organs and sensations which are considered as appetitive organs, Xunzi 荀子 (Wang Ba 王霸, 10) speaks about the relation of *qing* 情 with physical feelings and social consequences: “desires of ears and eyes”, and, more specifically, about the desires of the senses for colours, sounds, tastes, smells. Cf. Geaney 2002, 44-5; Nylan 2001, 94.

<sup>3</sup> *Mencius* 孟子, Jin Xin. xia 盡心下, 70. On self-cultivation, *Mencius*, Li Lou. shang 離婁上 15. See also “craving for food” *Gan shi* 甘食 (*Mencius*, Jin xin. shang, 27).

<sup>4</sup> For the bureaucratic metaphor of the senses in the early Chinese philosophy, see *Xunzi*, Tian lun 天論, 4; and *Zheng ming* 正名, 5, 12, 18, 19; *Mencius*, Gaozi shang 告子上, 7, 15; *Guanzi* 管子, Xin Shu. shang 心術上, 1, 4, 7, 8. For a similar position in Qing dynasty, see later Dai Zhen (*Mengzi ziyi shuzheng* 孟子字義疏證, 1:32). For an allegorical political interpretation of ancient texts, see Levi Sabattini 2015.

<sup>5</sup> Harper 1998, 412-14. For heat therapies and massage, see Harper 1998, 68, 91-5, 97-8 *passim*.

Before going on with this short survey, it is worthy to notice the holistic approach in traditional China, not only in the rejection of the subject-object distinction in the epistemological process (Ames 1991, 228). Scholars were well aware of the deep connection of sensory experiences with the emotional sphere of the subject and in cultural constructions (Santangelo, Middendorf 2006, 2, 59, 232, 236). This is evident in the symbolic, epistemological and aesthetic roles attributed to sensory functions. Moreover, the somatisation of emotions is manifested both in the medical discourse and in symbolic expressions of written language, for instance, the notions of ‘five viscera’ (*wuzang* 五臟) and ‘four limbs’ (*sizhi* 四肢). The sense organs and the heart-mind served as functional nodes in large circulatory systems governing the entire human body, and were situated within body-wide connections with the heart-mind, as nodal points for the flow of *qi* and blood. Most of the Neo-Confucian thinkers have dedicated their attention to the complementarity of mind and senses. This holistic perception of the unity of sensory functions was shared by most thinkers, also outside the School of Mind, from Liu Zongzhou 劉宗周 (1578-1645) to Wang Fuzhi 王夫之 (1619-92) and Dai Zhen 戴震 (1724-77).<sup>6</sup> Liu Zongzhou expressed the concept of the unity of mind and body, and stated that “ears, mouth, eyes, nose and the four limbs are all complete in the heart-mind”.<sup>7</sup> From Mencius to Wang Fuzhi and Dai Zhen, the functions of the senses are listed together with the functions of the heart-mind (*kou er mu xin* 口耳目心). Later thinkers, like Wang Fuzhi and Dai Zhen, have emphasised the unity of different functions in human beings, and have ‘legitimated’ the role of senses because they are not in contrast with cardinal virtues and rather mutually cooperate in the body, provided that sensorial organs follow their way. This approach explains also the role of the senses in the Neo-Confucian self-perfection process, which confirms the moral perspective from which most themes were debated. Senses are involved in spiritual exercises and the ‘practice of the self-cultivation process’ (*gongfu* 工夫).

<sup>6</sup> On the extensive use of ‘Neo-Confucianism’, see Santangelo 2016, 7 fn. 2.

<sup>7</sup> Liu Zongzhou, *juan 6*, in *Siku quanshu*, or Huang Zongxi, *Mingru xue’an*, 62:693-4.

### 3 Zhang Zai

The Neo-Confucian reflection on senses can be started from Zhang Zai 張載 (1020-77), in whose thought Xunzi's concept is crucial. In his *Zhengmeng* 正蒙 (Correcting Ignorance), Zhang Zai distinguishes two kinds of knowledge, superior moral learning and inferior sensory perception, limited to what one "hears and sees" (*Zhang Zai ji*, 6:20; 7:24).<sup>8</sup> "Knowing from hearing and seeing" was the sensory perception (*wenjian zhizhi* 聞見之知), the "narrow" (*xia* 狹) and "superficial knowledge through hearing and seeing" (*wenjian xiaozhi* 聞見小知), and it was contrasted with the "understanding through virtue and nature" (*dexing zhi zhi* 德性之知), the "holistic enlightened knowledge" (*cheng ming suo zhi* 誠明所知) (*Zhang Zai ji*, 6:20; 7:24).<sup>9</sup> The partiality and unreliability of the senses, however, were not based only on moral arguments, but were explained with philosophical and medical reasons: shapes, colours, sounds, smells, and other sensory aspects are easily changing, and are petty and insignificant phenomena. Moreover, individual perceptual errors for partiality (*pianjian* 偏見) are possible owing to "disease and delusion" (*ji yu wang* 疾與妄), i.e. eyes' sickness, such as cataracts or hallucinatory states (*Zhang Zai ji*, 6:20, cit. in Zuo 2019, 97-110).

This dichotomy created by Zhang Zai, based on the inadequacy of the sensorial cognitive function versus the deep intuitive/moral knowledge, remained in the writings of several scholars from Cheng brothers and Zhu Xi until the late imperial period, even with changes of meanings (Angle, Tiwald 2017, 112-22). Nevertheless, Zhang's analysis acknowledges the necessity and utility of senses owing to the combination of internality with externality: "Although ears and eyes [the senses] are considered a burden on human nature, they have the power to combine the inner and the outer, and knowing it is the crucial point to open up" (*Zhang Zai ji*, Da Xin 大心, 7:25).<sup>10</sup> This happens because human beings perceive (*wenjian* 聞見) the external signal through their senses that open one's body and consciousness,

<sup>8</sup> For his contemporary Shao Yong 邵雍 (1011-77), knowledge starts from sensory perception and reaches up to the intuition of mystical union. The senses just perceive objects, while the mind-heart understands a more profound reality, by means of figures (*xiang* 象) and numbers (*shu* 數), and finally "true knowledge" is reached by holiness through principle. Being beyond forms, principle offers a comprehension of the whole of reality. Cf. Arrault 2002, 242.

<sup>9</sup> Cf. also *Er Cheng yishu* 二程遺書, *juan* 25 (*Siku quanshu*, *zibu* 子部, Rujialei 儒家類 and *Zhuzi yulei*, 64:1560).

<sup>10</sup> Cf. Zuo 2019, 85. For another interpretation, that emphasises the contrast between sensorial and intuitive/moral knowledge, see Zheng 2015, 1256: "Zhang assumes that, although the senses are always considered a burden of the heart-mind, it is nonetheless the crucial point to open up to see (*qi* 啓 means both 'to open' and 'to see') that virtue which unifies the inner and the outer".

and this is the enlightenment (*qi* 啓) of “the virtue of the combination of external and internal” (*nei wai zhi he* 內外之合之德) (*Zhang Zai ji*, 7:25). This means that Zhang does not regard the senses themselves as the source of ethical failures or just a source of temptations that obstacles moral perfection. Without the function of sensory organs, man would not be able to perceive external reality (*ren zhi you shou* 人之有受) and would be like inanimate things (*Zhang Zi yulu*, Shang 張子語錄, 上, in *Zhang Zai ji*, 1:313).

However, Zhang raised critical questions on the reliability of the senses and distinguished a true knowledge, that only allows the perception of the unity of oneself with everything (*qi shi tianxia wu yi wu fei wo* 其視天下無一物非我), “the ability to embody all things of the universe” (*neng ti tianxia zhe wu* 能體天下之物) (*Zhang Zai ji*, Zhengmeng, 7:24). This knowledge is superior because it corresponds to the holistic feeling of the self in unity with the universe through a kind of intuition, “resonance” (*gan* 感) (*Zhang Zai ji*, Zhengmeng, 17:63, cit. by Zuo 2019, 89). He uses a neologism by combining terms used in the Classics, “what is understood through wholeness and enlightenment” (*cheng ming suo zhi* 誠明所知),<sup>11</sup> which refers to the concept of oneness, in communication with cosmic unity (*yiti* 一體). Borrowing the Mencian idea of one body in response to harm to others, Zhang Zai highlighted the metaphor of the sensitivity of the heart-mind to the conditions of one’s physical body, associated with empathy and reciprocity. This image leads to the sensitivity towards the conditions of all humans and other beings because humans have the same body as Heaven and Earth (*yu tian di tong ti* 與天地同體) and all things. This is the difference with the sensorial perception that is limited in comparison to this intuition and enlightenment.

#### 4 Zhu Xi

In his reorganisation of the previous Neo-Confucians’ thought, Zhu Xi maintains Zhang Zai’s distinction and extends it to the dyad of the superior knowledge of the “moral mind” (*daoxin* 道心), based on self-cultivation and virtuous behaviour, and the sensorial perception of the “human mind” (*renxin* 人心) in the everyday practical sensorial feelings like hunger, cold and itch (*Zhuzi Yulei*, 78:2010-13; 62:1486-7). Notwithstanding the late Ming and Qing criticism against his dichotomy of principle-desire and principle-energy, Zhu was more open than many of his followers who focussed on the rhetoric of the repression of desires in favour of heavenly principles. Zhu Xi morally

<sup>11</sup> Transl. by Zheng 2015, 1256-7.

accepts sensory desires, provided they are functional to the individual and social life, and correspond to the vital necessities, in contrast with desires for superfluous things. These sensory desires are associated with principles based on vitalistic and innate reasons: they are necessary (*bi* 必) and natural (*ziran* 自然). Human nature is received by Heaven and consists of innate morality (benevolence, righteousness, propriety, and wisdom), but its manifestations include also natural and universal desires (*Zhuzi Yulei*, 14:505). The classical desires for food, sex, music, aromas and body's leisure are among the various sensory desires Zhu includes in the concept of human nature, originated from "the naturalness of the Heavenly Principle" (*tianli zhi ziran* 天理之自然) (*Zhuzi Yulei*, 61:1461; see also Lee 2020, 281-4).

The first turning point can be seen in some thinkers of the late Ming period, especially the School of Mind. The role of all senses in self-cultivation exercises is examined by Wang Yangming 王陽明 (1472-1529). Dealing with the term *gewu* 格物 ('investigation of things'), he mentions the ears, the eyes, the mouth, the nose, and the four limbs that must not see, hear, say and behave against propriety. This is possible because the heart-mind is the master of the body. Sensory organs allow all perceptions and behaviour, but what makes it possible is the mind. Owing to the centrality of the mind, self-cultivation lies in

realizing through personal experience the true substance of one's mind and always making it broad and extremely impartial without the slightest incorrectness. Once the master is correct, then, as it operates through the channel of the eye, it will naturally see nothing which is contrary to propriety. As it operates through the channels of the ear, it will naturally hear nothing which is contrary to propriety. And as it operates through the channels of the mouth and the four limbs, it will naturally say or do nothing which is contrary to propriety. This means that the cultivation of the personal life consists in rectifying the mind. (*Wang Yangming Chuanxilu xia* 傳習錄下, 120)<sup>12</sup>

Activating will (*yi* 意) concentrates the visual and auditory faculties, so much so that "there are no principles that are not authentically understood" (Ng 1999, 108). Moreover, in the cat metaphor, self-cultivation is compared to the cat catching a mouse, with *eyes single-mindedly watching and ears single-mindedly listening*.

But sensory involvement is not limited to the metaphorical level. Wang Ji 王畿 (1498-1583), a Wang Yangming's disciple, explains the discipline in the use of senses, through the method of "restfulness/

<sup>12</sup> See *Instructions for Practical Living*: Chan 1963, 247, item 318.

liberation from sensorial temptations" (*genqibei* 艮其背).<sup>13</sup> His resort to the term *genqibei* recalls Cheng Hao's 程顥 (1032-85) statement, that the sage interacts with things without getting obsessed or burdened with temptations.<sup>14</sup> Paraphrasing Mencius (Jin Xin. xia, 70), he states that the sensory organs of the ears, eyes, mouth, nose and the four limbs act all on the surface, and only the back is not moving, so they perceive phenomena (*er mu kou bi siti zhu gen zhi yong, jie zai yu mian, wei bei wei bu dong, gu yi qu xiang* 耳目口鼻四體諸根之用, 皆在于面, 惟背為不動, 故以取象):

The eyes' disposition towards beautiful forms and colours, ears towards pleasant sounds, nose towards fragrant smells, mouth towards delicious tastes, and the four limbs towards leisure are all physiological natural principles, and therefore they belong to human nature. But there is the heavenly rule [*ming* 命], and to comply with it one fulfils his nature [*jie ziran zhi shengli, gu yue xing ye, ran you ming yan, liming suoyi jin xing ye* 皆自然之生理, 故曰性也, 然有命焉, 立命所以盡性也]. If you look at the colours restfully, the eye is not a conveyor of seduction but it cleverly can stop. If you hear the sounds restfully, the ear is not conveyor of seduction, and the listening is only conscientious. (*Longxi Wang xiansheng quanji* 龍溪王先生全集, *juan* 8, § *Gen zhi jing yi zhi zhi* 艮止精一之旨, 1)

At the beginning of this passage, Wang Ji seems to echo what Zhu Xi says about it.<sup>15</sup> In the second part, he follows Mencius: he recommends moderation in the use of senses, and their natural functions. In this respect, Wang Ji follows the common and orthodox opinion that sensorial experiences are natural but that the gentleman does not consider them as belonging to human nature, because only humanness, filiality and other virtues are the Heavenly morality (*sheng se chou wei anyi zishi tianxing* 聲色臭味安佚自是天性, 'music and beauties, smells and tastes, comfortable positions belong naturally to heavenly inclinations'). In another passage, Wang Ji discusses the use of the senses and their functions to affirm the priority of moral culti-

<sup>13</sup> The expression *genqibei* 艮其背, from the *Yijing* (*gen* 艮, hexagram 52 艮), is explained by Zhu Xi (*Zhuzi yulei*, 73:1850-8), as "keeping one's independence from external and sensual temptations in order to stop the growth of inner desire", following the Confucius' recommendation not to look at, listen to, speak, do what is contrary to propriety (*Lunyu*, Yan Yuan, 1). This expression was used by other previous writers such as Su Dongpo (SKQS 經部, 易類, 東坡易傳, 卷五) and Hu Hong 胡宏 (SKQS *Zhi yan* 知言, 4:4b).

<sup>14</sup> See Cheng Hao, "Dingxingshu 定性書", <https://zh.m.wikisource.org/zh-hant/定性書>. See Zheng Zemian's study (2015) on it.

<sup>15</sup> *waiwu bu jie, neiyu bu meng* 外物不接, 內欲不萌 (if we do not come across external things or affairs, no desires arise within). See Zhu Xi, *Zhuzi Yulei*, 73:1850-8, who develops *Lunyu*, Yan Yuan, 1.



vation and conscience. He starts from the Mencian affirmation “all things are already complete in us” (*wanwu jie bei yu wo* 萬物皆備於我, *Mencius*, Jin xin. shang, 4) to exalt “sincerity on self-examination”, and reciprocity (*shu* 恕). Then, he recalls Wang Yangming’s phrase, “the unity of all things is humaneness (*yiti zhi ren* 一體之仁) (*Wang Yangming Chuanxilu*, 142, 182), which is propaedeutic to his discourse on the interaction between man and other beings. Going on to examine the functioning of the senses, about sight he says: “In front of colours, my eyes can spontaneously distinguish blue and yellow, because the colours of all things are already complete in my eyes” (*wu zhi mu yu se zi neng bian qing huang, shi wanwu zhi se bei yu mu ye* 吾之目遇色自能辨青黃，是萬物之色備於目也). Then, referring to Wang Yangming’s principle of unity between knowledge and action (*zhixing heyi* 知行合一), by analogy, it passes to the mind and conscience with the immediate consequences on human behaviour: “Meeting my father, my mind’s conscience cannot but understand filial piety [*wu xin zhi liangzhi yu fu, zi neng zhi xiao* 吾心之良知遇父自能知孝]”. The process of seeing is analogous to or is the first step of the spontaneous moral reaction in everyday life.<sup>16</sup> The perception and distinction of colours, sounds, etc. derive from the fact that they are already in our sensorial organs, ‘already complete within the self’, like innate conscience provokes our spontaneous moral reactions to all vicissitudes of the world in front of us.

The Taizhou School attributed the highest value to the body-person, starting from Wang Gen 王艮 (1483-1541), who stated that the Way is respected when the body-person is respected and vice versa (道尊，則身尊。身尊則，道尊) (*Mingru xue’an* 明儒學案, 32:315). Luo Rufang 羅汝芳 (1515-88) confirmed the same concept and argued that “one’s own body is the Way” (cf. Zheng 2016, 400-6), and explained how sensorial perceptions allow the unlimited embodiment of objects and phenomena, by extending the self to the management of social and moral affairs (cf. Yu 2010, 398-406). For Luo Rufang and other Taizhou scholars self-cultivation (*xiushen* 修身) allows the flowing of the original positive energy from the universe to the four limbs of the body (*shenti sizhi* 身體四肢) and heart-mind, and thus the recovery of original natural conscience (*fu yi zizhi* 復以自知), by sharing the cosmic energy of the original yang (*iyiyang zhi qi* 一陽之氣) (cf. Zhang 2010, 42, 48, 64; 2012, 155-73).

16 Wang Ji 王畿 1976, 1-4. Cf. *Wang Yangming Chuanxilu*, 5, 8.

## 5 Li Zhi

During the social-economic changes and the consequent expansion of printing from the mid-Ming period, the growth of entertainment publications, the development of fiction and drama, practical and travel guides, sensual needs underwent great changes, and material desires were broadened (see Brokaw 1991; Chow 2004). Some thinkers, like Li Zhi, have questioned the relationship between principle and desire. Li Zhi quotes and comments on the *Hub of the Heart Sutra*, that records the Buddhist metaphysical doctrine of the emptiness of beings and their perceptions:

The Six Sense Roots are all empty: there are no eyes, ears, nose, tongue, body and mind. The Six Dusty Sense Fields are all empty: there are no sights, sounds, smells, tastes, sensations, or mental elements. (*Xinjing tigang* 心經提綱 [The Hub of the Heart Sutra], *Fenshu*, 3:100, transl. by Lebovitz 2016, 117)

But this emptiness (*kong* 空) is not different from the form (*se* 色) in the original nonduality of subject and object, existence and nonexistence. In his essay, emblematic of the Taizhou School's Dao-Buddhist-Confucian syncretism, Li Zhi emphasises the role of the heart-mind to get the self-realisation of the nonduality of opposites, forms and emptiness, as well as the potentiality of everyone to achieve wisdom by using his/her mind. What is new is his ethical approach, as Li Zhi acknowledges the importance of senses for the vital function of desires for food, clothing, wealth, advantages, economic and social improvements, as they are the natural expressions of the childmind (*tongxin* 童心) and do not distract from moral effort. Their fulfilment is the bright virtue of the childmind and they naturally correspond to the universal order; like food and clothing, wealth, advantages, economic and social improvements fulfil the five senses that are endowed by Heaven: this is their natural condition (Li Zhi, *Da Geng Zhongcheng* 答耿中丞, *Fenshu*, 1:17).<sup>17</sup>

<sup>17</sup> Chow (2020, 152-3) emphasises the great changes from the orthodox morality: while Zhu Xi considered wealth, life's satisfactions, pleasures and rank something depending on destiny and thus not worthy of care and temptations for selfish desires, here Li Zhi claims they are natural tendencies, that enrich the five senses endowed by Heaven.

## 6 Wang Fuzhi

Another turning point started with Wang Fuzhi's criticism of a supposed Dao-Buddhist refusal of sensory experience, and his appreciation of taste and smell as coming from the interaction with other beings.<sup>18</sup> Wang Fuzhi's exploration of nature and political legitimacy was influenced by western scientific knowledge and methods (Lin 2010; Xu 2012). In his arguments against the distinction between the "ordering principle" (*li* 理) and "humoral energy" (*qi* 氣), he states the original moral potentiality and psychophysical nature, and refers to senses and virtues as examples of the unity of the body. Heaven creates human beings through the five phases of yin and yang energies. Then, the principle is located in man and is concentrated in human nature. Consequently, through his senses, sounds and images, smells and tastes enrich man's life (*hou qi sheng* 厚其生), as well as the four cardinal virtues of humaneness, justice, propriety and wisdom, confirm human morality, so that everything is suitable to principle. Therefore, he concludes that if senses follow their way, they are not in contrast with Confucian cardinal virtues, and rather mutually cooperate in the body (*Zhangzi Zhengmeng Zhu*, Cheng ming pian 誠明篇, 3:79).

On the one side Wang, exploring sensorial perception (*ti zhi jue* 體之覺), singles out "shape [i.e. touch sensation and pain], sound, smell, taste, warmth and cold" (*xing ye, sheng ye, chou ye, wei ye, wenliang ye* 形也, 聲也, 臭也, 味也, 溫涼也) (*Zhangzi Zhengmeng zhu*, Dong wu pian 動物篇, 3:68-9)<sup>19</sup> and follows the idea of limitations of sense perception in the process of learning and understanding reality: "The power of sight and hearing is limited in perceiving the smallest" (*er mu zhi li qiongyu xiao* 耳目之力窮於小) (1:9, 13).<sup>20</sup> On the other side, Wang Fuzhi is critical of the Dao-Buddhist refusal of sensorial experience and its concupiscible effects.<sup>21</sup> He takes issue with Laozi's criticism of the senses, as well as his influences on Neo-Confucianism: "Laozi says that 'the five colours blind man's eyes, the five sounds deafen man's ears, and the five savours confuse man's taste'. This reasoning means to avoid to look for [mistakes] in oneself, and

<sup>18</sup> See Wang Fuzhi's commentary in Zhang Zai, *Zhangzi Zhengmeng zhu*, Qian cheng pian, xia 乾稱篇下, 9:42. Cf. Gernet 2005, 254. For the original source of Zhang Zai's sentence, see Zhang Zai, *Zhang Zai ji*, 6:22.

<sup>19</sup> See <https://ctext.org/wiki.pl?if=gb&chapter=123173>.

<sup>20</sup> See also Gernet 2005, 244-8. In *Du Sishu daquanshuo* 讀四書大全說, 191, Wang expresses his appreciation for "the sole and unique function of mind [*xin guan du zhi zhi gong* 心官獨致之功] in reaching principle beyond senses and shapes [*yu xing'er shang yongsi* 於形而上用思]". Cf. <https://ctext.org/wiki.pl?if=gb&chapter=644850&remap=gb#p192>.

<sup>21</sup> See Wang Fuzhi's commentary in Zhang Zai, *Zhangzi Zhengmeng zhu*, Qian cheng pian, xia 乾稱篇下, 9:42. Cf. Gernet 2005, 254.

rather blame external things”.<sup>22</sup> Analysing Zhang Zai’s words, namely that “[t]he appetite for foods and drink, and the sense of smell and taste towards scents and aromas are always a conquest of human nature”,<sup>23</sup> Wang Fuzhi notices that such phenomena come from interaction with other beings because it is through sensorial organs that we perceive the reality of the world. To sum up, senses are associated with desires: they get along well and match each other in dealing with external things, thus desires automatically arise. This is a natural process, as desire is not only what petty people rely on, but also what gentlemen cannot ignore.<sup>24</sup> At the same time, he makes explicit the need for moderation (*jie* 節, *jian* 儉): excess and indulgence (*ren* 任, *chi* 侈) bring disasters (*yang bi ji shen* 殃必及身) to oneself and society (*Du Tongjian Lun*, 30:49-51, 19:55).<sup>25</sup>

Moreover, Wang Fuzhi’s exploration of cognitive efforts goes beyond the distinction made by many thinkers between the inferior and superior knowledge we have mentioned, but at the same time, he confirms the limits of human cognitive tools, the perception capacity of the senses and the expressive potentiality of language. He refutes the concept that identifies reality with its representation and underlines that a large part of reality escapes our perceptions and conceptualisations. Thus, reality cannot be limited to what one sees or hear, so that “what the eye does not see is not necessarily without shape [*mu suo bujian fei wuse ye* 目所不見, 非無色也]; what the ear does not hear is not necessarily without sound; what the word does not communicate is not necessarily without meaning”. Wang concludes that, in researching, despite the efforts made by sight, hearing and language, there will always be forms, sounds and concepts that escape our capacity (*Siwenlu* 思問錄, *nei pian* 內篇, in *Xuxiu Siku* 續修四庫, *zi* 子, vol. 945, 553, 船山思問錄, 4).<sup>26</sup>

<sup>22</sup> See also *Shangshu yinyi*, 6:170; *Zhangzi Zhengmeng zhu*, 3:104.

<sup>23</sup> 口腹於飲食, 鼻舌於臭味, 皆攻取之性也 *Zhang Zai ji*, 6:22; *Zhangzi Zhengmeng Zhu*, *Cheng ming pian* 誠明篇, 3:94; *Zhangzi quanshu*, 6, 2:18b.

<sup>24</sup> 耳目口體於天下之物, 相得而各有合, 欲之所自興, 亦天也, 匪徒小人之所依, 抑君子之所不能去也 *Song Lun* 宋論, 2:38 (Taizong 太宗). Cf. <https://ctext.org/wiki.pl?if=gb&chapter=602253#p39>. Desires are defined as striving for satisfying the requests of senses (*er mu kou ti zhi ge you suoshi er qiude zhi zhe, suowei yu ye* 耳目口體之各有所適而求得之者, 所謂欲也), *Du Tongjian Lun* 讀通鑿論 (Reading Sima Guang’s *Zizhi Tongjian* 資治通鑑), 30:49.

<sup>25</sup> Wang Fuzhi, in his comment to the *Zuozhuan* (Duke Zhuang, 24, 儉, 德之共也, 侈, 惡其大也 “frugality is the reverence of virtue, while extravagance is the great evil”) explains that *jian* 儉 and *chi* 侈 should not be intended as ‘frugality’ and ‘extravagance’ in the economic sense, but rather as ‘self-control’ and ‘indulgence-excess’, respectively. For *yang bi ji shen* 殃必及身, cf. *Mencius*, Jin Xin. xia 盡心下, 74: “If one value as most precious pearls and jade, calamity is sure to befall him [*bao zhuyu zhe, yang bi ji shen* 寶珠玉者, 殃必及身] [instead of valuing the territory, the people, the government]”.

<sup>26</sup> See <https://ctext.org/wiki.pl?if=gb&chapter=273173#p5>.

## 7 Yan Yuan

Another innovator, Yan Yuan 顏元 (1635-1704), in his essay “Preservation of Learning” (*Cunxue bian* 存學編), deals with senses and sensorial desires. He argues that principle and energy are together the heavenly Way, like human nature and body are together endowed by Heaven; similarly, innate morality (*xingming* 性命) and physical tendencies (*qizhi* 氣質) in man, although individually different, together constitute this goodness (*Cunxue bian*, in *Yan Yuan ji*, 1:48-9). In another work, “Preservation of Human Nature” (*Cunxing bian* 存性編), Yan Yuan seems to echo certain concepts expounded by Wang Fuzhi, whose works however could not be published until the middle nineteenth century, and thus their influence began later. Both of them, nevertheless, were influenced by Jesuits. Starting from the exposition of his cosmological theory, he equates psychophysical nature with human nature, that is, with good and innate goodness. He criticises the dualism of the Cheng brothers and Zhu Xi for their dichotomy principle-energy and the Daoist influences on Neo-Confucianism. By analysing sight, eyes are used as an argument against traditional concepts. He distinguishes the physical substance (the eye socket, the bulb and the pupil) and principle/nature (its sight), to make fun of the contrast between the fallibility of the latter and the purity of the former, between heavenly nature and physical nature (*Cunxing bian*, 1:89).<sup>27</sup> What makes ears, eyes, mouth and body feel satisfied and thus aspire to gain is called ‘desire’, and thus the biological need and satisfaction of the human body as desire.

## 8 Dai Zhen

Analogously, Dai Zhen criticises the current opinion that regards sensory likings and desires as arising from the psychophysical endowment, separated from principle (*Mengzi ziyi shuzheng* 孟子字義疏證, 1:32). Reinterpreting Mencius, Dai argues that the hedonic natural tendency of senses is not different from the heart-mind’s tendency towards morality, and it is one of the three basic functions together with emotional and aesthetic-moral ones. For Dai Zhen, referring to Xunzi, the mind consists of three faculties: desires (*yu* 欲), emotions (*qing* 情), and aesthetic-moral discernment (*zhi* 知). Human nature is nothing but blood, vital energy and heart-mind (*Mengzi ziyi shuzheng* 孟子字義疏證, 3:65-7). Desires are produced by sensory experiences, sounds, shapes, smells and tastes, from which one feels attraction and repulsion; passions are manifested in joy, anger, sad-

<sup>27</sup> See <https://ctext.org/wiki.pl?if=gb&chapter=563881&remap=gb>.

ness and pleasure, for which one feels restlessness and satisfaction; by the judgment of the conscience, one likes or dislikes what is beautiful and what is ugly, what is right and what is wrong (*Mengzi ziyi shuzheng* 孟子字義疏證, 3:66).

Dai singles out the innate ability of humans to react to external stimuli, both on sensorial, emotional and intellectual levels. Tastes, sounds, and shapes belong to things but are perceived by one's physical nature, and moral principles belong to human affairs but are perceived by one's aesthetic-moral sense. Physical nature and aesthetic-moral sense have their own tools: the mouth is able to distinguish tastes, the ear to distinguish sounds, the eye to distinguish shapes, and the heart-mind to distinguish moral principles. Tastes, sounds, and shapes belong to things and not to the individual, but when they are perceived by one's physical nature (*xueqi* 血氣), this can distinguish and appreciate them, and what it appreciates should be the best (*Mengzi ziyi shuzheng* 孟子字義疏證, 1:31). Sensory organs allow communication between the body and external things, but each organ, the open portal of this communication, has its own functions: "The heart can direct the ear, the eye, the nose, and the mouth, but it cannot take over their powers. Their powers are each already adequate [to their several functions], and therefore [the various faculties] cannot act in each other's stead" (1:33, transl. by Ewell 1990, 138). Thus, the inclinations of the physical body are various and respond to the specific needs of the ear, eye, nose, and mouth, but are not rooted in the heart-mind. When senses are guided by the heart-mind (*xin zhi guan, jun dao ye* 心之官, 君道也), then the satisfaction of senses corresponds to the conscience, and nature is fully realised in man (1:33). In this way Dai Zhen comes back to the "rule of the heart-mind", but this position does not prevent him from condemning the orthodox bias against desires. Dai also accuses Zhu Xi and his school to be influenced by Dao-Buddhist prejudices against desires (1:35-46). Worthy of note is that Dai Zhen, like Wang Fuzhi, was acquainted with the writings of the Jesuits and was influenced by western culture, on the basis of their statement of "Western learning originated from China" (*xixue Zhong yuan* 西學中源) (Tao 2014; Lin 2010; Xu 2012).

The findings show the interest of Neo-Confucian thinkers in sensorial functions and experience. The priority of moral perspective in dealing with bodily sensations is quite evident: sensory experiences turn into desires, repulsions, passions and reactions that have effects on individual balance and social relationships. The somatisation of emotions is facilitated by the holistic conception of the body and its parts, a conception shared by most of Neo-Confucian thinkers. Senses are supposed to cooperate with the mind, under its control, and are involved in self-cultivation practices.

This survey affords merely a concise analysis of a few selected thinkers, to selectively explore the historical continuity and evolution

of how Neo-Confucians thought about senses and morality. Zhang Zai has been selected because he was one of the founders of the Neo-Confucian metaphysical structure, and influenced later important thinkers, like Zhu Xi and Wang Fuzhi. Zhang's contribution to the distinction between two different kinds of knowledge, the superior moral intuition and the inferior sensorial perception, concerns both gnosology and self-perfection practices, the difference between need and desire for the superfluous. Then, I tried to follow the development of ideas during the economic and social transformations in the second part of the Ming dynasty, by presenting some key passages from Wang Yangming and his school. Finally, I examined Wang Fuzhi's new approach, and his return to the orthodoxy but with some significant innovations. The late great Qing thinkers Yan Yuan and Dai Zhen show a new practical perspective, based on their criticism of Zhuxi's school and its diffidence for senses and desires. From this survey a few constant elements of the debate on the senses are evident. By the way, these few but significant examples show a holistic approach, and above all highlight the 'legitimation' of senses in the *li-qi* 理-氣 discussion or their role in the self-cultivation process. What thinkers were interested in was the vitalistic and hedonic character of senses and the moral supervision of the mind in a holistic concept of the body, whose organs are always considered in connection with the heart-mind. Analyses of the cognitive functions of senses and their role were often framed in the debate on the principle-desires relationship and also in the self-cultivation process, but the emphasis was on the holistic vision of the person rather than the detailed functioning of every sensory organ. The scarce attention to the physiological functions of the senses, if compared with western analytical writings as appears in the Jesuits' writings (Meynard 2020), is probably motivated by their presumed epistemic inferiority to the superiority of the intuition of the mind.

## Bibliography

For ancient Chinese texts and Classics, if no mention is done to specific editions, see the *Chinese Text Project* website: <https://ctext.org>.

### Chinese Sources

- Cheng Yi 程頤; Cheng Hao 程顥. *Er Cheng yishu* 二程遺書 (Remnant books of the two Cheng brothers), *Siku quanshu* [SKQS] Zibu 子部, Rujia lei 儒家類.
- Dai Zhen 戴震 (1956). *Mengzi ziyi shuzheng* 孟子字義疏證 (Evidential Commentary on the Meanings of Terms in Mencius). *Yuanshan* 原善 (Inquiry into Goodness). Beijing: Renmin chubanshe.
- Huang Zongxi 黃宗羲 (1984). *Mingru xue'an* 明儒學案 (Treatise on the Ming Scholars). Taipei: Shijie shuju.
- Liu Zongzhou 劉宗周. *Liu Jishan ji* 劉戡山集, in *Siku quanshu*, Jibu 集部, 別集類, 明洪武至崇禎.
- Siku Quanshu* (Complete Library of the Four Treasuries [SKQS]) (1986). Taipei: Taiwan shangwu yinshuguan (electronic edition at the *Wenyuange Siku Quanshu* 文淵閣四庫全書電子版 (Electronic Edition of the Wenyuange Complete Library of the Four Treasuries).
- Wang Ji 王畿 (1976). *Longxi Wang xiansheng quanji* 龍溪王先生全集 (The Complete Collection of Master Wang Ji). Vol. 98. *Siku quanshu cunmu-congshu* 四庫全書存目叢書, Jibu 集部. <https://ctext.org/wiki.pl?if=gb&res=60613>.
- Wang Fuzhi 王夫之. *Shangshu yinyi* 尚書引義 (Explanations of the Book of History). Beijing: Zhonghua shuju.
- Wang Fuzhi 王夫之. *Siwenlu* 思問錄. Vol. 945. *Xuxiu Siku* 續修四庫, zi 子.
- Wang Fuzhi 王夫之 (1975). *Zhangzi Zhengmeng Zhu* 張子正蒙注 (An Annotated Anthology of Zhang Zai). Beijing: Zhonghua shuju. <https://ctext.org/wiki.pl?if=gb&res=807100>.
- Wang Yangming 王陽明 (1963). *Wang Yangming Chuanxilu* 王陽明傳習錄 (Wang Yangming's Instructions for Practical Living). *Wang Wengong Quanshu* 王文成公全書 (Erudite Wang Yangming's Complete Works). Sibū congkan 四部叢刊. Shanghai: Shangwu yinshuguan. Transl. by Chan, W. (ed.) (1963). *Instructions for Practical Living and Other Neo-Confucian Writings*. New York: Columbia University Press.
- Yan Yuan 顏元 (1987). *Yan Yuan ji* 顏元集 (Yan Yuan's Collected Works). Beijing: Zhonghua shuju. <https://ctext.org/wiki.pl?if=gb&res=900395&remap=gb>.
- Zhang Zai 張載 (1978). *Zhang Zai ji* 張載集 (An Anthology of Zhang Zai). Beijing: Zhonghua shuju.
- Zhang Zai 張載. *Zhangzi quanshu* 張子全書 (Zhang Zai's Complete Writings). *Siku quanshu* (Zibu, Rujia lei).
- Zhu Xi 朱熹 (1983). *Zhuzi Yulei* 朱子語類 (Thematic Discourses of Master Zhu). Beijing: Zhonghua shuju. <https://ctext.org/zhuzi-yulei/10>.



## Essays

- Ames, R. (1991). "Meaning as Imaging: Prolegomena to a Confucian Epistemology". Deutsch, E. (ed.), *Culture and Modernity: East-West Philosophic Perspectives*. Honolulu: University of Hawai'i Press, 227-44.
- Angle, S.; Tiwald, J. (2017). *Neo-Confucianism: A Philosophical Introduction*. Cambridge: Polity.
- Arrault, A. (2002). *Shao Yong (1012-1077), poète et cosmologue*. Paris: College de France.
- Balaban, Y. (2012). "Double Mimesis: Sensory Representations in Literature". Isomaa, S. et al. (eds), *Rethinking Mimesis: Concepts and Practices of Literary Representation*. Newcastle: Cambridge Scholars Publishing, 159-77.
- Brokaw, C. (1991). *The Ledgers of Merit and Demerit: Social Change and Moral Order in Late Imperial China*. Princeton: Princeton University Press.
- Chow, K. (2004). *Publishing, Culture, and Power in Early Modern China*. Stanford: Stanford University Press.
- Chow, K. (2020). "An Avatar of the Extraordinary: Li Zhi as a Shishang Writer and Thinker in the Late-Ming Publishing World". Handler-Spitz, R.; Lee, P.; Saussy, H. (eds), *The Objectionable Li Zhi: Fiction, Criticism, and Dissent in Late Ming China*. Seattle: University of Washington Press, 145-63.
- Csikszentmihalyi, M. (2004). *Ethics and the Body in Early China*. Leiden; Boston: Brill.
- Ewell, J.W. (1990). *Re-Inventing the Way: Dai Zhen's 'Evidential Commentary on the Meanings of Terms in Mencius' (1777)* [PhD dissertation]. Berkeley: University of California.
- Geaney, J. (2002). *On the Epistemology of the Senses in Early Chinese Thought*. Honolulu: University of Hawai'i Press.
- Gernet, J. (2005). *La Raison des choses. Essai sur la philosophie de Wang Fuzhi (1619-1692)*. Paris: Gallimard.
- Harper, D. (1998). *Early Chinese Medical Literature: The Mawangdui Medical Manuscripts*. London: Kegan Paul.
- Knoblock, J. (1990). *Xunzi: A Translation and Study of the Complete Works*. Stanford: Stanford University Press.
- Lebovitz, D. (2016). "The Hub of the Heart Sutra". Handler-Spitz, R.; Lee, P.; Saussy, H. (eds; transls). *A Book to Burn & a Book to Keep (Hidden): Li Zhi Selected Writings*. New York: Columbia University Press, 114-18.
- Lee, J. (2020). "Zhu Xi's Metaphysical Theory of Human Nature". Ng, K.; Huang, Y. (eds), *Dao Companion to Zhu Xi's Philosophy*. Cham: Springer Nature, 265-87.
- Levi Sabattini, E. (2015). "The Physiology of *Xin* (Heart) in Chinese Political Argumentation: The Western Han Dynasty and the Pre-Imperial Legacy". *Frontiers of Philosophy in China*, 10(1), 58-74.
- Lin Zhenwu 林振武 (2010). "Wang Fuzhi dui xifang kexue de renshi ji qi lishi diwei" 王夫之对西方科学的认识及其历史地位 (Wang Fuzhi's Understanding of Western Science and Its Historical Position). *Jiaying xueyuan xuebao* 嘉应学院学报, 28(4), 33-7.
- Meynard, T. (2020). "Introducing the Sensitive Soul in Late Ming China: Aleni's *Xingxue cushu* 性學概述". *Rivista degli Studi Orientali. Nuova serie*, 93(4), 37-46.
- Møller-Olsen, A. (2021). *Sensing the Sinophone: Urban Memoryscapes in Contemporary Fiction*. Amster; New York: Cambria Press.

- Ng, O. (1999). "An Early Qing Critique of the Philosophy of Mind-Heart (*Xin*): The Confucian Quest for Doctrinal Purity and the Doxic Role of Chan Buddhism". *Journal of Chinese Philosophy*, 26(1), 89-120.
- Nylan, M. (2001). "On the Politics of Pleasure". *Asia Major*, 14(1), 73-124.
- Santangelo, P. (2014). "The Perception of Pain in Late-Imperial China". Bod-dice, R. (ed.), *Pain and Emotion in Modern History*. Basingstoke: Palgrave Macmillan, 36-52.
- Santangelo, P. (2016). *L'uomo fra cosmo e società. Il neoconfucianesimo e un mil-lennio di storia cinese*. Milano: Mimesis.
- Santangelo, P. (2018). "The Lover's Eye: Image and Love in Medieval-Renaissance Europe and Late Imperial China". *International Communication of Chinese Culture*, 5, 173-95.
- Santangelo, P. (2019). "Olfaction and Other Senses in Chinese Culture: A Com-parative Analysis, with Special Attention to the Use of the Term *Xiang*". *En-tangled Religions*, 10. <https://doi.org/10.13154/er.10.2019.8408>.
- Santangelo, P. (2022). "The Culture of Smells: From Huchou to Tianxiang, Ta-boo and Sublimation". Wu, S.; Huang, X. (eds), *Sensing China: Modern Trans-formations of Sensory Culture*. New York: Routledge, 42-67.
- Santangelo, P.; Middendorf, U. (eds) (2006). *From Skin to Heart: Perceptions of Bodily Sensations and Emotions in Traditional Chinese Culture*. Wiesbaden: Harrassowitz.
- Seok, B. (2013). *Embodied Moral Psychology and Confucian Philosophy*. Lan-ham: Lexington Books.
- Slingerland, E.; Chudek, M. (2011). "The Prevalence of Mind-Body Dualism in Early China". *Cognitive Science*, 35, 997-1007.
- Tao Wu 陶武 (2014). "Dai Zhen Xixue sixiang shuyi" 戴震西学思想庶议 (On Dai Zhen' Thoughts on Western Learning). *Anhui shifandaxue xuebao* 安徽师范大学学报. 人文社会科学版 (Journal of Normal University of Anhui. Aca-demy of Social Sciences), 42(6), 716-21.
- Wu, S.; Huang, X. (eds) (2022). *Sensing China: Modern Transformations of Sen-sory Culture*. New York: Routledge.
- Xu Sumin 许苏民 (2012). "Wan Ming xixuedongjian dui Wang Fuzhi zhengzhi zhixue de yingxiang" 晚明西学东渐对王夫之政治哲学之影响 (Late Ming Eastern Trend of Western Learning Political Influence on Wang Fuzhi's Thought). *Chuanshan xuekan* 船山学刊, 4, 1-10.
- Yang Rubin 楊儒賓 (1996). *Rujia shentiguan* 儒家身軀觀 (Confucian View of Bo-dy). Taipei: Academia Sinica.
- Yu, H. (2010). "'All Things Are Already Complete in My Body': An Explanation of the Views of the Taizhou School on the Human Body". *Frontiers of Philoso-phy in China*, 5(3), 396-413.
- Zhang Meijuan [Chang Mei Chuan] 張美娟 (2010). "Yi Yang zhi Qi, Haidi Hong-lun yu Sizhi Xuwen: Luo Jinxi 'Chizi zhi Xin' Xiangguan Yiti Shitan" 一陽之氣, 海底紅輪與四肢學問——羅近溪 '赤子之心' 相關議題試探 (The Qi of the Original Yang [Energy Flow of One Yang], the Red Rising Sun from the Depths of the Ocean [*Muladhara Cakra*], and the Learning from the Four Limbs: Some Theses About Luo Jinxi's 'Notion of the Heart of a Child'). *Qin-ghua Zhongwen Xuebao* 清華中文學報, 4, 37-72.
- Zhang Meijuan 張美娟 (2012). "Cong 'Yi Yang zhi Qi' Kan Luo Jinxi de Shen-ti Guan" 從 '一陽之氣' 看羅近溪身體觀 (Luo Jinxi's View of the Body: From the Perspective of the 'Qi of the Original Yang [Energy Flow of One Yang]'). *Taipei Daxue Zhongwen Xuebao* 臺北大學中文學報, 11(3), 149-80.

<https://www.airitilibrary.com/Publication/aDetailedMesh?DocID=19931638-201203-201206050016-201206050016-149-180>.

Zheng, Z. (2015). "Two Kinds of Oneness: Cheng Hao's Letter on Calming Nature in Contrast with Zhang Zai's Monism". *Philosophy East and West*, 65(4), 1253-72.

Zheng, Z. (2016). "Thinking Through the Heart of a Child: Luo Jinxi on Body and Ritual". *Ming Qing Studies*, 267-85.

Zuo, Y. (2019). "Zhang Zai's (1020-1077) Critique of the Senses". *Journal of Chinese History*, 3, 83-111.



**The Historian's Gaze**  
Essays on Modern and Contemporary China  
in Honor of Guido Samarani  
edited by Laura De Giorgi and Sofia Graziani

## Authors' Bio

**Hongmin Chen** is Qiushi Distinguished Professor of Zhejiang University, People's Republic of China. He is the Director of the Center for Chiang Kai-shek and Modern China at Zhejiang University, and his field of interest is the Chinese History of Republican Period. His publications include more than 20 books and 150 articles. He was visiting scholar at Harvard-Yenching Institute, Harvard University (1996, 2002, 2009), at Yonsei University in Korea (2004), at Hoover Institution, Stanford University (2008, 2010, 2017), and at Ca' Foscari University of Venice in Italy (2019). Professor Chen's recent research program is to build the Database of Chiang Kai-shek's Material.

**Aglaia De Angeli** is Senior Lecturer in Modern Chinese History at Queen's University Belfast. With a background in sinology, she specialized in social and law history of Republican China. She researches equally the role and legacy of the Sino-Western encounter between 19th and 20th centuries on nowadays China's leading role in the world. As part of the Sir Robert Hart Project at Queen's, she works on historical photography in China and was the Principal Investigator of the ESRC funded project 'Competing Imperialism in Northeast Asia' (1894-1953).

**Laura De Giorgi** is Full Professor of Chinese History at Ca' Foscari University of Venice. Her research interests include the history of media and propaganda in twenty-century China and the cultural relations between Italy and China in the modern and contemporary era. She is the President of the European Association of Chinese Studies. Among her publications *Contact Zones in China: Multidisciplinary Perspectives* (with Merle Schatz and Peter Ludes, 2020); *Chiang Kai-shek and His Time. New Historical and Historiographical Perspectives* (with Guido Samarani, 2017); *La Via dell'Oppio. Europa e Cina nel periodo dei trattati ineguali* (2013).

**Federica Ferlanti** is Lecturer in Modern Chinese History at Cardiff University. Her research field is Republican history and specifically China's state building, political history, and mobilization campaigns. She has published on the New Life Movement, state building, civilian mobilization, and wartime China. She is currently working a monograph that analyses political culture and civilian mobilization in Nationalist China.

**Elisa Giunipero** is Full Professor of Chinese History at the Faculty of Linguistic Sciences and Foreign Literatures, Università Cattolica del Sacro Cuore (Milan) and the Italian Director of the Confucius Institute at the same university. She is a member of the Board of directors of the Italian Association of Chinese Studies (AISC). Her academic interests include: History of Christianity in China, History of China-Europe cultural exchanges in the perspective of World History, Chinese social and religious history, History of international relations during the Cold War.

**Sofia Graziani** is Associate Professor at the University of Trento where she teaches History of modern and contemporary China and Chinese language and culture. Her research focuses on the history of the CCP and its youth organizations, China's international relations during the Cold War and Beijing's people-to-people diplomacy and soft power strategy. She is the author of *Il Partito e i giovani. Storia della Lega giovanile comunista in Cina* (2013) and *La Cina rossa. Storia del Partito comunista cinese* (with Guido Samarani, 2023). Since 2019 she is a board member of the Italian Association of Chinese Studies.

**Marina Miranda** is Full Professor of History of Contemporary China at the 'Sapienza' University of Rome. Scientific Supervisor of the East Asia section of the Ph.D. course in Civilization of Asia and Africa and Coordinator of the same Ph.D course until 2018. President of the Italian Association for Chinese Studies (A.I.S.C.). Scientific Director of the editorial series 'Studi Orientali' (LibreriaUniversitaria.it) and 'Cina Report' (Carocci); member of the Editorial Committee of the magazine *Rivista degli Studi Orientali*, of the Scientific Committee of the periodicals *Mondo Cinese*, *Sulla Via del Catai* and of the editorial series 'Ricerche sull'Oriente' (Sapienza University Press). Author and editor of the following volumes: *La Democrazia in Cina* (2012); *La Cina dopo il 2012* (2013); *Politica, società e cultura di una Cina in ascesa* (2016); *La Cina quarant'anni dopo Mao* (2017); *Ideologia e riforma politica in Cina* (2022).

**Barbara Onnis** is Associate Professor of History and Institution of Asia at the Department of Political and Social Sciences (Cagliari University), where she teaches Contemporary China and International Politics of Asia. Her research interests are mainly focused on the international relations and foreign policy of PRC. Her most recent publications include *Fino all'ultimo Stato. La battaglia diplomatica tra Cina e Taiwan* (with F. Congiu, Carocci 2022); "COVID-19 and China's Global Image" in *US-China Competition, COVID-19, and Democratic Backsliding in Asia, Asia Maior* (edited by G. Pugliese, A. Fischetti, M. Torri, special issue, 2, 2022); *La politica estera della RPC. Principi, politiche e obiettivi* (Aracne, 2020).

**Andrea Revelant** is Associate Professor of Japanese History in the Department of Asian and North African Studies at Ca' Foscari University of Venice. His research focuses on policy making processes, popular representation and mass communication in imperial Japan. He is the author of *Sviluppo economico e disuguaglianza* (2016) and *Il Giappone moderno* (2018). He is currently working on the political discourse on China in the Japanese press of the interwar years.

**Paolo Santangelo** is Emeritus of the Sapienza University of Rome, editor of *Ming Qing yanjiu* (1992-2007) and *Ming Qing Studies* (from 2010), directs the 'Emotions and States of Mind in East Asia' series (Brill), and 'Asia Orientale 古今東亞'. He is the author of numerous articles and volumes, including *Revisiting Liaozhai zhiyi* (2018); *The Culture of Love in China and Europe* (with Gábor Boros, 2020); *Individual Autonomy and Responsibility in Late Imperial China* (2021).

**Yu Shen** PhD., is Professor of History and International Studies in the School of Social Sciences at Indiana University Southeast in New Albany, Indiana. She was born and raised in Beijing, China and completed her doctoral work at the University of Illinois, Urbana-Champaign. Shen is particularly interested in the histories and cultures of China and Japan, as well as foreign relations between the United States and East Asian countries. While her research focuses on U.S.-China relations, her teaching covers a wider range of topics. Her goal over the past 20 years at IUS is to expand East Asian Studies offerings. With a grant sponsored by the U.S. Government's National Defense Education Act (NDEA), she has converted many of her traditional face-to-face courses into online courses.

**Larry N. Shyu** (徐乃力) is Professor Emeritus of UNB. Taught East Asian History for 30 years before retirement in 1998. Married with five grown children. Larry has a B.A. from the Normal University of Taiwan, an M.A. from the University of Washington, and a Ph.D. from Columbia University in New York. Taught at Hong Kong Baptist University and Hobart & William Smith Colleges (New York) before joining UNB. He has served as visiting professor of a number of universities in China, Taiwan, and Australia. Larry served as President of the Fredericton Branch of the Canadian International Relations Institute (1985-87); Vice-President of the Canadian Asian Studies Association (1986-88); President of the Historical Society for the 20th Century China (1994-96); and Member of the Advisory Committee on Multiculturalism of NB Department of Education (1992-95). Larry Shyu has authored and co-authored 6 scholarly books; published 16 articles and about 20 book reviews in refereed journals.





# Sinica venetiana

1. Abbiati, Magda; Greselin, Federico (a cura di) (2014). *Il liuto e i libri. Studi in onore di Mario Sabattini*.
2. Greselin, Federico (a cura di) (2015). *La lingua cinese: variazioni sul tema*.
3. Lippiello, Tiziana; Chen Yuehong 陈跃红; Barengi, Maddalena (eds) (2016). *Linking Ancient and Contemporary. Continuities and Discontinuities in Chinese Literature*.
4. De Giorgi, Laura; Samarani, Guido (eds) (2017). *Chiang Kai-shek and His Time. New Historical and Historiographical Perspectives*.
5. Samarani, Guido; Meneguzzi Rostagni, Carla; Graziani, Sofia (eds) (2018). *Roads to Reconciliation. People's Republic of China, Western Europe and Italy During the Cold War Period (1949-1971)*.
6. Basciano, Bianca; Gatti, Franco; Morbiato, Anna (eds) (2020). *Corpus-Based Research on Chinese Language and Linguistics*.
7. D'Attoma, Sara (2022). *Famiglie interrotte. Violenza domestica e divorzio nella recente legislazione della Repubblica Popolare Cinese*.
8. Bianchi, Ester; Campo, Daniela; Paolillo, Maurizio (a cura di) (2022). *Quali altre parole vi aspettate che aggiunga?*
9. Scarin, Jacopo (2023). *The Tongbai Palace and Its Daoist Communities: A History*.

This volume brings together a group of historians of modern China and East Asia, who have shared with Guido Samarani the experience of studying China in the last thirty years. It represents a small tribute to a friend and colleague, whose outstanding research activities have greatly increased our understanding of Chinese modern and contemporary history. Inspired by Samarani's vast and multiple research interests, the essays collected in this volume weave together new interpretations and perspectives on the history and historiography of modern and contemporary China, covering a broad range of periods and topics, from imperial times to the contemporary age.



Università  
Ca'Foscari  
Venezia